

UNIMIG



***POWERED AIR PURIFYING RESPIRATOR
WELDING HELMET***



Powered Air Purifying Respirator Welding Helmet

U11152

Contents

1. Safety	3
2. Features	7
3. Specifications	8
4. Introduction	11
5. Package Contents	13
6. Assembly	14
7. Before Use	19
8. Fitting	23
9. LCD & Operation	24
10. Parts Breakdown	25
11. Replacing the Filters	26
12. Maintenance & Storage	28
13. Warning Sound Indication	31
14. Warranty	32

1. Safety

Welding and cutting equipment can be dangerous to both the operator and people in or near the surrounding working area, if the equipment is not correctly operated. Equipment must only be used under the strict and comprehensive observance of all relevant safety regulations. Read and understand this instruction manual carefully before the installation and operation of this equipment.

Machine Operating Safety

- Do not switch the function modes while the machine is operating. Switching of the function modes during welding can damage the machine. Damage caused in this manner will not be covered under warranty.
- Disconnect the electrode-holder cable from the machine before switching on the machine, to avoid arcing should the electrode be in contact with the work piece.
- Operators should be trained and or qualified.

Items in the manual that require particular attention in order to minimise damage and harm are indicated with the below symbols. Read these sections carefully and follow their instructions.

 **Note:** Gives the user a useful piece of information.

 **Caution:** Describes a situation that may result in damage to the equipment or system.

 **Warning:** Describes a potentially dangerous situation. If not avoided, it will result in personal damage or fatal injury.



Electric Shock

Electric shock: It can kill. Touching live electrical parts can cause fatal shocks or severe burns. The electrode and work circuit is electrically live whenever the output is on. The input power circuit and internal machine circuits are also live when power is on. In MIG/MAG welding, the wire, drive rollers, wire feed housing, and all metal parts touching the welding wire are electrically live. Incorrectly installed or improperly grounded equipment is dangerous.

- Connect the primary input cable according to Australian and New Zealand standards and regulations.
- Avoid all contact with live electrical parts of the welding/cutting circuit, electrodes and wires with bare hands.
- The operator must wear dry welding gloves while he/she performs the welding/cutting task.
- The operator should keep the work piece insulated from himself/herself.



- Keep cords dry, free of oil and grease, and protected from hot metal and sparks.
- Frequently inspect input power cable for wear and tear, replace the cable immediately if damaged, bare wiring is dangerous and can kill.
- Do not use damaged, under sized, or badly joined cables.
- Do not drape cables over your body.
- We recommend (RCD) safety switch is used with this equipment to detect any leakage of current to earth.

Fumes & Gases

Fumes and gases are dangerous. Smoke and gas generated whilst welding or cutting can be harmful to people's health. Welding produces fumes and gases. Breathing these fumes and gases can be hazardous to your health.

Do not breathe the smoke and gas generated whilst welding or cutting, keep your head out of the fumes

- Keep the working area well ventilated, use fume extraction or ventilation to remove welding/cutting fumes and gases.
- In confined or heavy fume environments always wear an approved air-supplied respirator.
- Welding/cutting fumes and gases can displace air and lower the oxygen level causing injury or death. Be sure the breathing air is safe.
- Do not weld/cut in locations near de-greasing, cleaning, or spraying operations. The heat and rays of the arc can react with vapours to form highly toxic and irritating gases.
- Materials such as galvanized, lead, or cadmium plated steel, containing elements that can give off toxic fumes when welded/cut. Do not weld/cut these materials unless the area is very well ventilated, and or wearing an air supplied respirator.



Arc Rays

Arc rays: harmful to people's eyes and skin. Arc rays from the welding/cutting process produce intense visible and invisible ultraviolet and infrared rays that can burn eyes and skin.

Always wear a welding helmet with correct shade of filter lens and suitable protective clothing including welding gloves whilst the welding/cutting operation is performed.

- Measures should be taken to protect people in or near the surrounding working area. Use protective screens or barriers to protect others from flash, glare and sparks; warn others not to watch the arc.



Fire Hazard

Welding/cutting on closed containers, such as tanks, drums, or pipes, can cause them to explode. Flying sparks from the welding/cutting arc, hot work piece, and hot equipment can cause fires and burns. Accidental contact of electrode to metal objects can cause sparks, explosion, overheating, or fire. Check and be sure the area is safe before doing any welding/cutting.

- The welding/cutting sparks & spatter may cause fire, therefore remove any flammable materials well away from the working area. Cover flammable materials and containers with approved covers if unable to be moved from the welding/cutting area.
- Do not weld/cut on closed containers such as tanks, drums, or pipes, unless they are properly prepared according to the required Safety Standards to insure that flammable or toxic vapours and substances are totally removed, these can cause an explosion even though the vessel has been “cleaned”. Vent hollow castings or containers before heating, cutting or welding. They may explode.
- Do not weld/cut where the atmosphere may contain flammable dust, gas, or liquid vapours (such as petrol)
- Have a fire extinguisher nearby and know how to use it. Be alert that welding/cutting sparks and hot materials from welding/cutting can easily go through small cracks and openings to adjacent areas. Be aware that welding/cutting on a ceiling, floor, bulkhead, or partition can cause fire on the hidden side.



Gas Cylinders

Shielding gas cylinders contain gas under high pressure. If damaged, a cylinder can explode. Because gas cylinders are normally part of the welding/cutting process, be sure to treat them carefully. CYLINDERS can explode if damaged.

- Protect gas cylinders from excessive heat, mechanical shocks, physical damage, slag, open flames, sparks, and arcs.
- Insure cylinders are held secure and upright to prevent tipping or falling over.
- Never allow the welding/cutting electrode or earth clamp to touch the gas cylinder, do not drape welding cables over the cylinder.
- Never weld/cut on a pressurised gas cylinder, it will explode and kill you.
- Open the cylinder valve slowly and turn your face away from the cylinder outlet valve and gas regulator.



Gas Build Up

The build up of gas can causes a toxic environment, deplete the oxygen content in the air resulting in death or injury. Many gases use in welding/cutting are invisible and odourless.

- Shut off shielding gas supply when not in use.
- Always ventilate confined spaces or use approved air-supplied respirator.



Electronic Magnetic Fields

MAGNETIC FIELDS can affect Implanted Medical Devices.

- Wearers of Pacemakers and other Implanted Medical Devices should keep away.
- Implanted Medical Device wearers should consult their doctor and the device manufacturer before going near any electric welding, cutting or heating operation.



Noise Can Damage Hearing

Noise from some processes or equipment can damage hearing.

- Wear approved ear protection if noise level is high.



Hot Parts

Items being welded/cut generate and hold high heat and can cause severe burns.

Do not touch hot parts with bare hands. Allow a cooling period before working on the welding/cutting gun. Use insulated welding gloves and clothing to handle hot parts and prevent burns.



WARNING: Contains button battery, hazardous if swallowed. Keep out of reach from children. Battery can cause severe or fatal injuries in 2 hours or less if it is swallowed or placed inside any part of the body. Medical attention should be sought immediately if it is suspected the battery has been swallowed or placed inside any part of the body.

2. Features

1/1/1/1 Classification

Superior optical clarity with a 1/1/1/1 classification. Get an Auto-Darkening Filter (ADF) that's scored top marks across the board for a crystal-clear view of your weld at every angle.

100x83.4mm View Size

Superior visibility in every situation. The 100x84.3mm viewing area lets you see every weld with complete clarity.

99.95% Filtration

The powered respirator keeps fresh, clean air pumping around your face so that you can breathe easily while you weld. The certified TH3 filtration has an inward leakage protection level of less than 0.2% in addition to P3 filters, meaning 99.95% of fumes and particles are removed, keeping you free of welding fumes, particles and gases.

External Grind Button

Seamlessly switch to grind mode with the click of a button so you can keep the helmet on. No need to remove any of your safety gear.

EliteVision Lens Technology

See your weld clearly in true colour. EliteVision technology allows more colours from the spectrum to pass through the view, giving you better optical clarity and reducing eye fatigue.

Up To 10 Hours Battery*

Work a full shift charging up. The built-in 4400mAH lithium-ion battery gives you up to 10 hours of battery life on the lowest intensity, with quick and easy recharging of the power adapter.

*Lasts up to 6 hours on the highest intensity.

Memory States

Store up to three of your most frequently used shade settings with the memory state buttons, and have your helmet ready to go in an instant.

4 Arc Sensors

Detect every arc instantly. The four optimally positioned arc sensors trigger the lens, darkening it and keeping your eyes shielded from the start, even when you're out of position.

3. Specifications

3.1 Helmet Specifications

Parameter	Values
Filter Dimensions	114x133x9.5mm
View Size	100x83.4mm
Arc Sensors	4
Classification	1/1/1/1
Light State	4
Dark State	5-9 / 5-13
UV/IR Protection	DIN15
Time from Light to Dark	0.08ms
Time from Dark to Light	0.1-0.9s
Sensitivity Delay	Adjustable (1-5 for low-high)
Power Supply	Solar Cells & CR2450 Replaceable Battery
Warranty	2 Years
Operating Temperature	-10°C to 65°C
Storage Temperature	-20°C to 85°C
Shade Control	Yes (Internal)
Grind Mode	Yes (Internal)
Minimum TIG Amperage	3A
Standards	AS/NZS 1337.1 B (High Impact) AS/NZS 1338.1 (Auto-Darkening)

3.2 PAPR Blower Unit Specifications

Parameter	Values
Air Filter	TH3 / P3
Noise Level	Max 73dB
Air Flow	Level 1: 170L/min Level 2: 200L/min Level 3: 230L/min
Expected Operation Time	Level 1: 10 hours Level 2: 8 hours Level 3: 6 hours
Battery Type	Rechargeable Li-ION 4400mAh
Battery Charging Time	3.5 Hours

Please read and understand all instructions before using.

- Be sure that the dark shade of the lens in the welding helmet is on the correct shade number for your application.
- The helmet and lenses are not suitable for “overhead” welding application, laser welding, or laser cutting applications.
- Welding helmets are designed to protect the eyes and face from sparks, spatter, and harmful radiation under normal welding conditions.
- This helmet will not protect against explosive devices or corrosive liquids. Machine guards or eye splash protection must be used when these hazards are present.
- Impact resistant, primary eye protection, spectacles or goggles that meet current AS/NZS specifications, must be worn at all times when using this welding helmet.
- Avoid work positions that could expose unprotected areas of the body to sparks, spatter, direct and/or reflected radiation. Use appropriate protection if exposure cannot be avoided.
- Before each use, check that the protection plates are clean and that no dirt is covering the sensors on the front of the lens.
- Inspect all operating parts before each use for signs of wear or damage. Any scratched, cracked, or pitted parts should be replaced immediately.
- Do not make any modifications to either the welding lens or helmet, other than the breathing tube specified in this manual. Do not use any replacement parts other than the breathing tube specified in this manual. Unauthorised modifications and replacement parts will void the warranty and expose the user to the risk of personal injury.
- If this lens does not darken when striking an arc, stop welding immediately and check the helmet is in Weld Mode and not Grind Mode. If the issue persists, contact your local UNIMIG Service Department.
- Do not immerse this lens in water.
- Do not use any solvents on any lens or helmet components.
- The recommended operating temperature range for this welding lens is -10°C to 65°C (14°F-149°F). Do not use this device beyond these temperature limits.
- Failure to follow these warnings and/or failure to follow all of the operating instructions could result in severe personal injury.

4. Introduction

The Powered Air Purifying Respirator (U11152) system is a combined face and breathing protection device for increased safety and comfort during welding. Please read these instructions carefully before unpacking. For proper use, see User Instructions or contact the manufacturers for help.

The Powered Air Purifying Respirator system should include:

- Auto-darkening welding helmet
- Blower unit with attached battery and filter
- Belt
- Battery charger
- Airflow indicator
- Instruction manual
- Backpack

If any of the above components are not included in your kit, please contact the supplier immediately.

Approvals

The U11152 system complies with the requirements of Australian/New Zealand standard AS/NZS 1716:2012 as a PAPR-P3 device. All components used in Powered Air Purifying Respirator system must be “UNIMIG approved” manufacturer’s parts, and must be used in accordance with the instructions in this manual.

 **Note:** The approval is not valid if the product is incorrectly used together with non-approved parts or components.

 **Note:** Only the U11152 filter, gas filter and pre-filter can be used together with this system. Filters from other manufacturers should under no circumstances be used.

Usage

The Powered Air Purifying Respirator system is designed to provide a supply of filtered air via a breathing tube to a welding headpiece. The complete system is a breathing protection device complying with Australian/New Zealand standard AS/NZS 1716:2012, class P3. The equipment can be used in environment that requires a class P3 breathing protection device. It protects against particulate contamination.

Limitations of Use

The Powered Air Purifying Respirator system must only be used with the blower unit switched on. If the equipment is used without the blower unit switched on, there is a risk of high concentration of CO₂ and the oxygen level in the helmet will fall, thus little or no protection is given in the power-off state and this is considered to be an abnormal situation. Do not remove the helmet or turn off the air filter unit until you have vacated the contaminated area. If you are not sure about the concentration of pollution, or about equipment performance, ask the industrial safety engineer. The manufacturer is not responsible for injury following incorrect use or incorrect choice of equipment.

- DO NOT use the helmet with the blower unit switched off.
- DO NOT use the helmet in an atmosphere that is immediately hazardous to user hygiene or health and or has oxygen content of less than 19.5% or contains unknown substances.
- DO NOT use the helmet in an explosive atmosphere.
- DO NOT use the helmet in high winds.
- DO NOT alter or modify in any way.
- DO NOT touch any of the moving parts.
- DO NOT allow water or other liquids to enter the impeller chamber, the filter or battery compartment.
- DO NOT use the the helmet as head protection.



Warning: This head covering does not meet the requirements of AS/NZS 1801. If head protection is required consult your safety officer.

- The helmet and lenses are not suitable for “overhead” welding application, laser welding, or laser cutting applications.

5. Package Contents

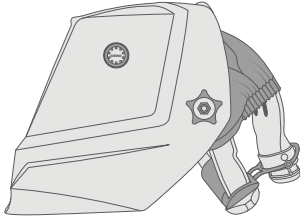

PAPR Helmet with Airduct



Blower Unit

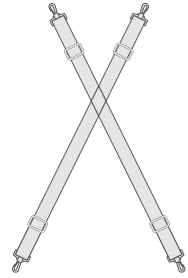

Shoulder Straps

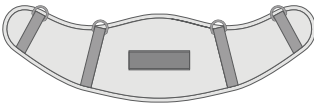

Belt

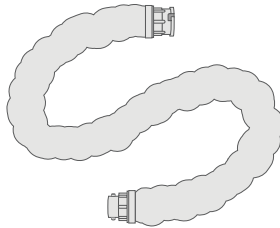

Breathing Tube



Carry Bag

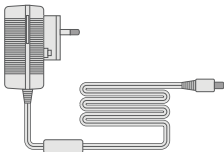

Battery Charger



Airflow Tester



Pre-Filter

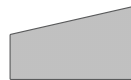

Spark Protector

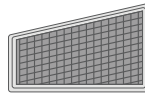

Filter

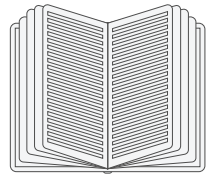

Manual



Battery



Belt Strap

6. Assembly

1. Open the blower unit and check the spark protector, pre-filter and filter.

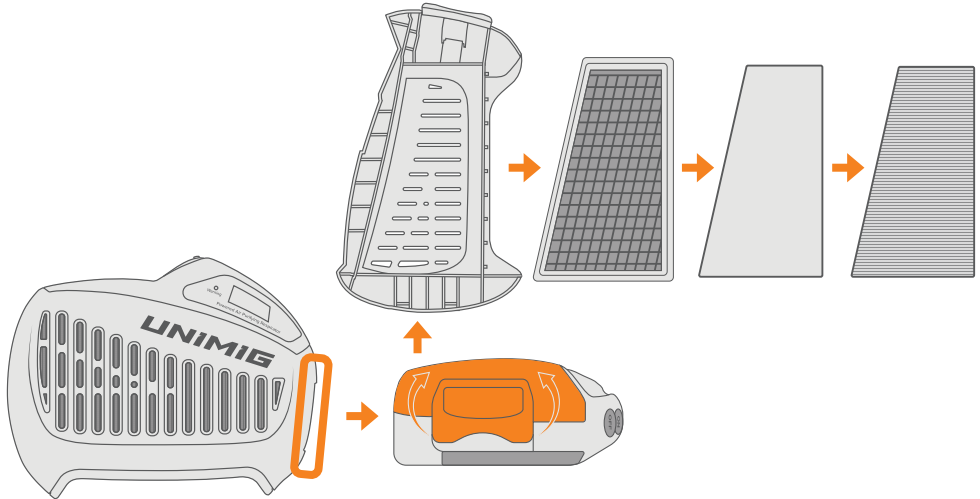

2. Replace the filter back into the casing if it's in good condition.

a. Place the spark protector into the filter cover.

b. Place the pre-filter into the filter cover, on top of the spark protector.

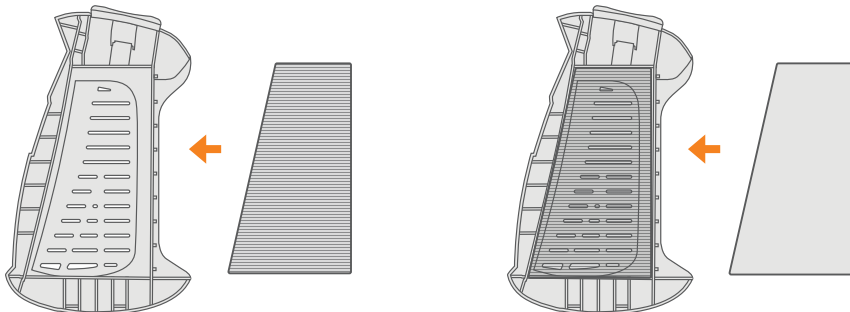

- c. Place the filter into the filter cover, on top of the pre-filter.

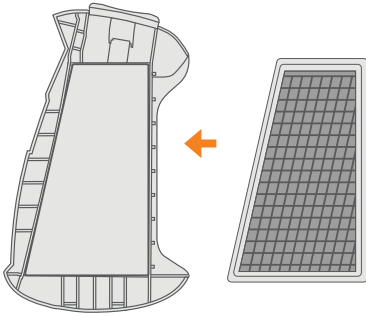

- d. Click the filter cover back into the blower unit.

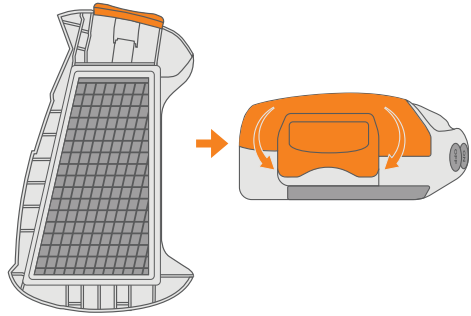

Note: Make sure that the filter is properly placed into the casing while installing.

Caution: DO NOT directly fit the filter to the helmet.

- 3. Install the blower unit on the belt.

- a. Remove the release buckle from the belt.



- b. Draw the belt out from the right side of the waist connector.

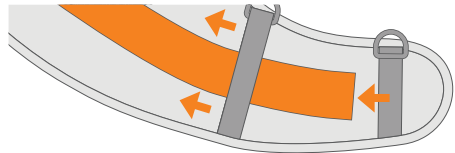

- c. Slide the belt into the blower unit through the two slots on the back side of the unit, with the velcro side facing up.

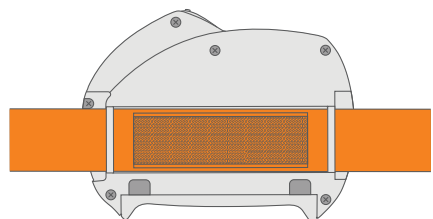
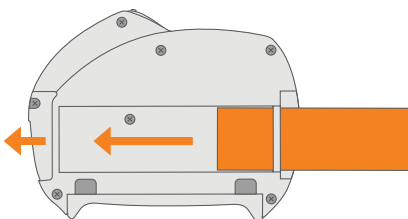

- d. Connect the velcro of the belt to the velcro on the back of the blower unit.

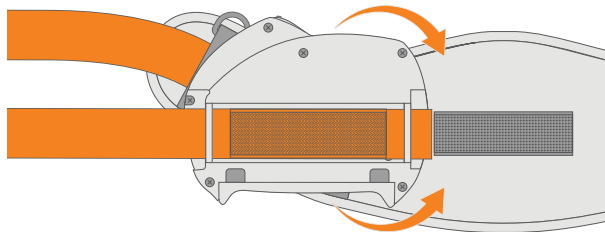

- e. Feed the belt back through the other side of the waist connector.

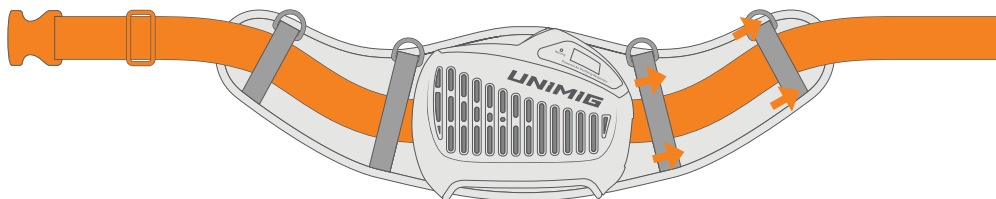

- f. Put the release buckle back onto the end of the belt.

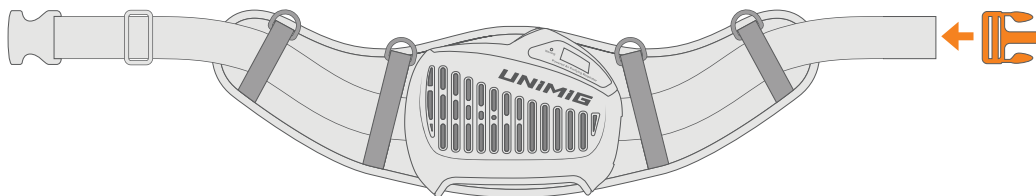

- g. Attach the shoulder straps to the four attachment points on the belt. Adjust the belt tightness so it fits well on your shoulders and waist.

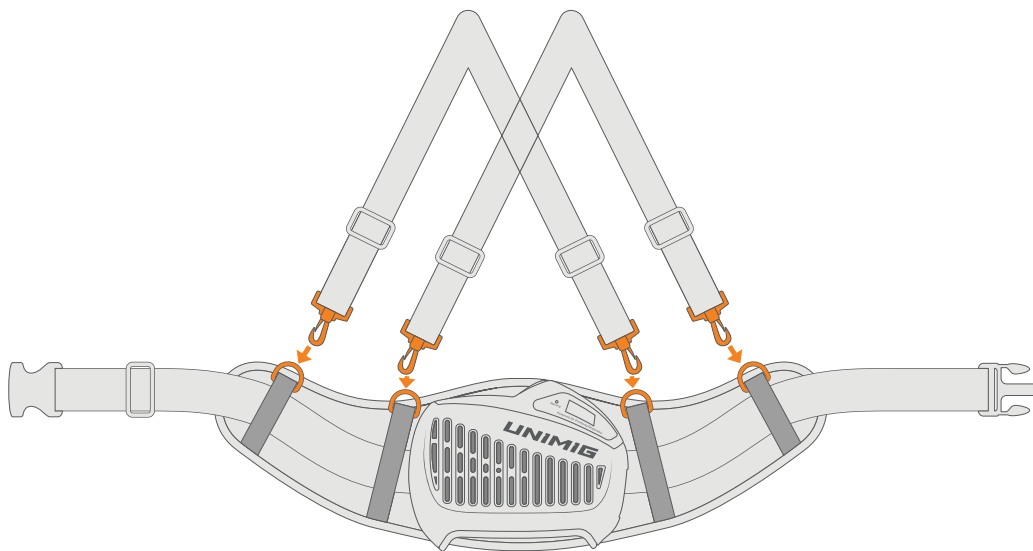

Note: Check that the belt is securely fastened.

4. Connect the breathing tube between the welding helmet and the blower unit. Check that the breathing tube is securely fastened.

⚠ Caution: If breathing tube is broken, replace it immediately.

- a. Connect breathing tube to blower unit.

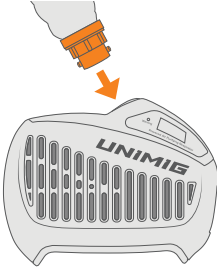

- b. Twist breathing tube to lock it into place.

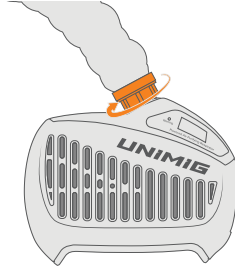

- c. Connect breathing tube to the helmet, making sure line up the bayonet lock.

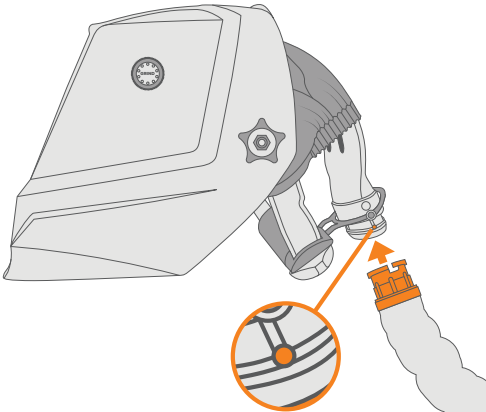

- d. Twist the tube to lock it into place.

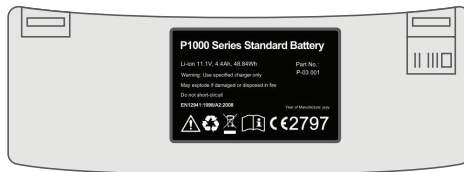
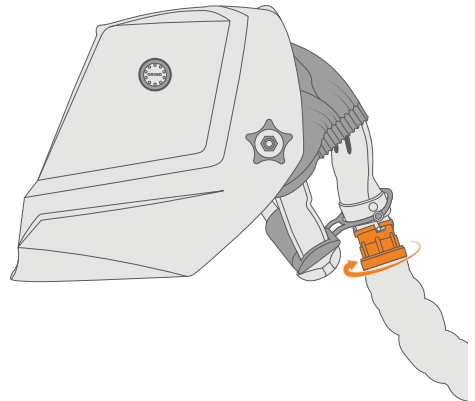

ⓘ Note: Carefully observe the instructions that explain how the equipment is to be used, before taking it into service. All components must be installed and operated in accordance with this manual if the equipment is to offer the specified protection. If any component is missing, or if anything is not clear, contact the supplier.

7. Before Use

Battery Charging

The system has a 100-240V or 100-240 volt, 1.5A battery charger. The battery can be charged when installed in the blower unit or separately.

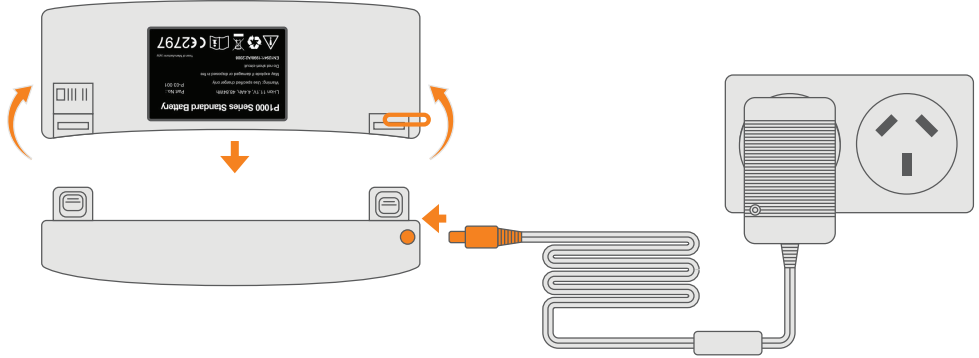

⚠ Caution: The battery can only be charged with supplied battery charger (Part No. P-06 03 001).

All new units must be charged before they are used for the first time.

The battery charger must not be used in any circumstances for any other purpose than for which it was manufactured. It is intended for indoor use (must be protected from moisture) and must not be used to charge non-rechargeable batteries.

The red light goes on during battery charging and will turn green when it is fully charged.

The battery will discharge during a long period in storage. For this reason, always re-charge the battery if it has been stored for more than 15 days. To achieve maximum power when the battery is new, or has been stored for more than 3 months, charge and discharge the battery at least twice, remove the battery out of the blower unit and store separately.

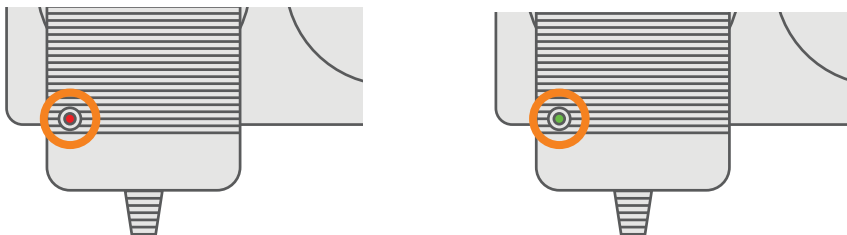

Points of attention:

1. Check that the mains supply voltage to the charger is correct.
2. Connect the battery charger to the wall socket.
3. Connect the battery charger to the battery.

⚠ Caution: If the blower unit starts while the unit is charging, switch it off immediately.

The battery icon on the blower unit indicates the battery capacity, not the charging state. Always refer to charging the light to determine if the battery is charging.

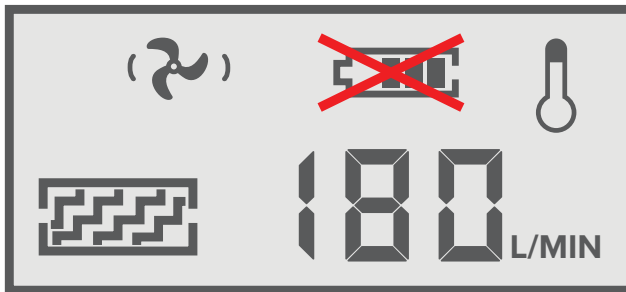

(Does not indicate charging)

If the charger indicator light will not light up when connecting the charger to the battery, please check the battery's charge connector and the charger's cords and connectors.

4. After charging is completed, disconnect the battery charger from the mains supply.
5. Disconnect the battery from the battery charger.

i Note: The filter must be changed if the battery operating time becomes too short.

Checking the Airflow

The airflow and alarm system must always be checked before using.

1. Remove the breathing tube from the helmet.
2. Connect the airflow tester to the breathing tube.

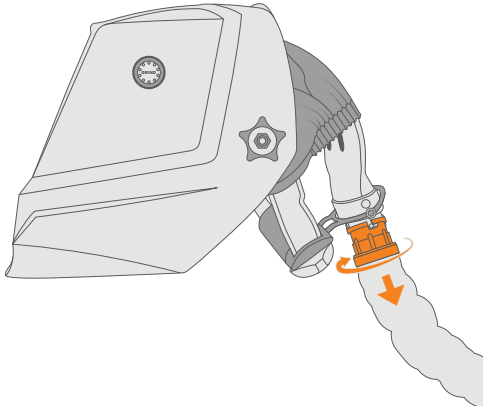

3. Turn on the blower unit.

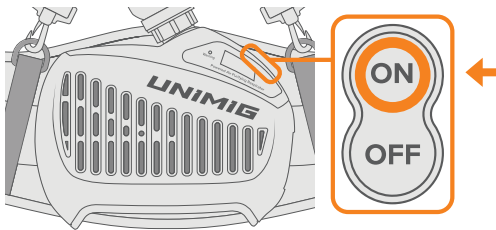

4. If the ball moves above the marked line, the system is safe to use.

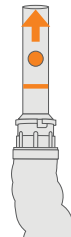

⚠ Caution: Don't use the system if the ball is below the marked line. Check the filter and the battery and retest the air flow.

Checking the Low Airflow Alarm

1. Remove the breathing tube from the helmet.
2. Turn on the blower unit.

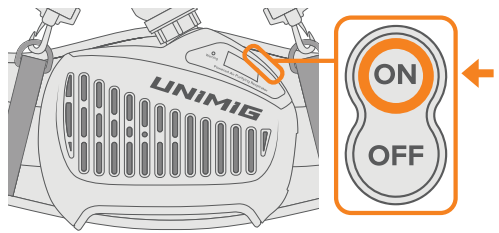
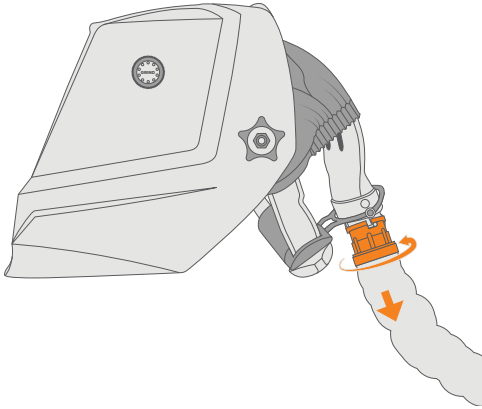

3. Cover the air outlet with your hand for 15 seconds.
4. The alarm will sound and the warning light on the blower unit will flash.

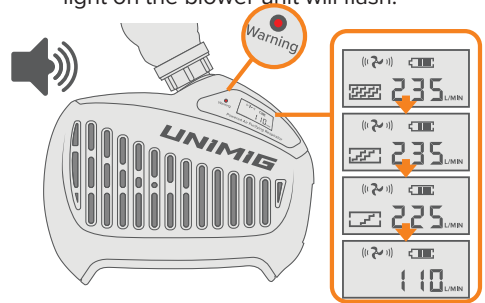
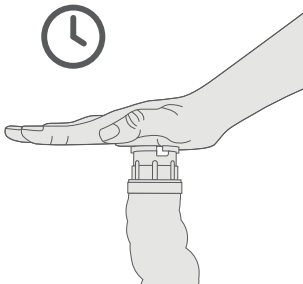

Note: If the alarm does not work, please change the blower unit.

Warning: Leave the contaminated area immediately if any of the following applies:

1. Any part of the system becomes damaged.
2. Airflow into the helmet decreases or stops.
3. Breathing becomes difficult.
4. Dizziness or other distress occurs.
5. You taste or smell contaminants or an irritation occurs.

8. Fitting

- Adjust the belt and shoulder strap size, so that the blower unit sits comfortably on your hips and is accessible.
- Adjust the headgear to suitable tightness so that it will be stable on the head. The tightness of the headgear can be adjusted by pushing and turning the adjusting knob.
- The face seal should rest against your face, with a comfortable pressure on your temples. If the face seal doesn't make contact with your face, you will not get sufficient sealing needed to offer the correct protection factor.
- Check that the facial unit is stable on the head and has no moving parts. Turn on the system and check there's no abnormal noise and no air leakage.

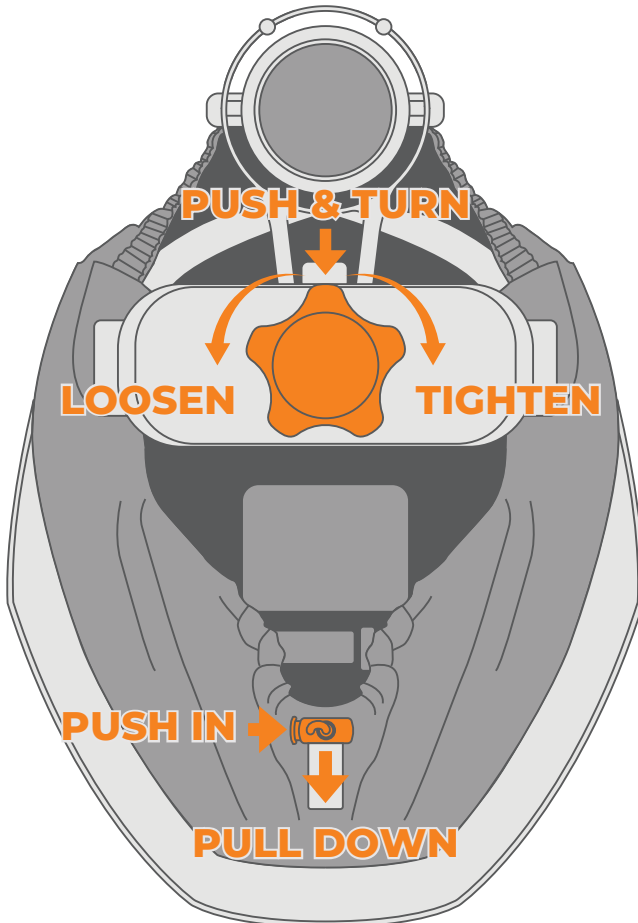

9. LCD & Operation

LCD

There is an LCD display on blower unit to show the working condition

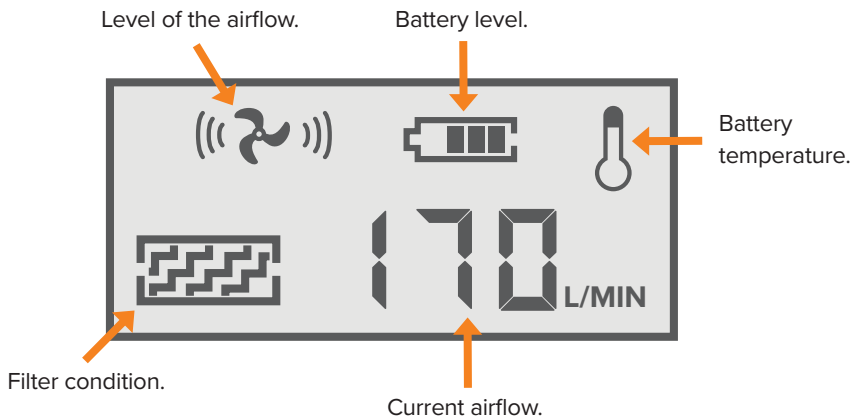

Any of them will flash if U11152 malfunctions.

Operation

- Start the blower unit by pressing the “on” button on the blower unit. The system is working at **level 1**.
- Press the “on” button again. The system is working at **level 2**.
- Press the “on” button again. The system is working at **level 3**.
- Press the “on” button again. The system is working back to **level 1**.
- Press the “off” button for at least 3 seconds to turn the PAPR off.

Note: There are 3 levels of airflow. Level 1 is no lower than 165L/min, level 2 is 200L/min, and level 3 is 230L/min.

- The PAPR will shut down the entire circuit and switch to sleep mode if not used for more than 30 minutes. Press the “on” button to activate the system.
- The PAPR must be operated in the temperature range of -5°C to +55°C and relative humidity less than 90%RH.

10. Parts Breakdown

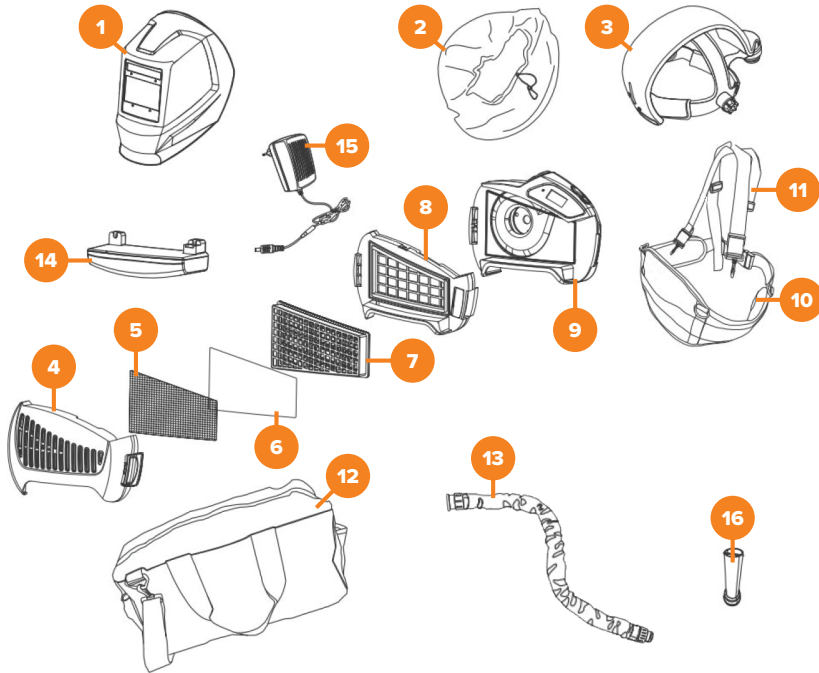

Drawing Number	Part Number	Description
1	P0101	WELDING HELMET ONLY SUIT PAPR (Helmet Shell & ADF)
2	U11199	FACE SEAL SUIT PAPR U11152
3	U11200	AIRDUCT HARNESS SUIT PAPR U11152
4	P0401	FILTER COVER SUIT PAPR
5	P0402	SPARK ARRESTOR SUIT PAPR
6	P0403	PREFILTER SUIT PAPR
7	P0404	FILTER SUIT PAPR
8	U21016*	NUISANCE ODOUR FILTER SUIT PAPR *Optional Accessory
	U21017*	NUISANCE ODOUR PAD SUIT PAPR *Optional Accessory
9	U11201	BLOWER UNIT SUIT PAPR U11152
10	P0501	WAIST BELT SUIT PAPR
11	P0502	DUAL SHOULDER STRAP SUIT PAPR
12	P0503	CARRY BAG SUIT PAPR
13	U11202	BREATHING TUBE SUIT PAPR U11152
14	P0301	RECHARGABLE BATTERY LI-ION SUIT PAPR
15	P0603	BATTERY CHARGER SUIT PAPR
16	P0604	AIRFLOW TESTER SUIT PAPR

Spare Parts

Part Number	Description
U21023	OUTER PROTECTION LENS KIT
U11198	SWEAT BAND SUIT PAPR U11152

11. Replacing the Filters

The installed filter has a limited service life based on working conditions. When the filter mark on the screen flashes and the alarm rings, the filter should be replaced. If the filter is installed but unused, it has a service life of 3 years.

1. Remove the filter cover by pressing in the latch of the filter cover.

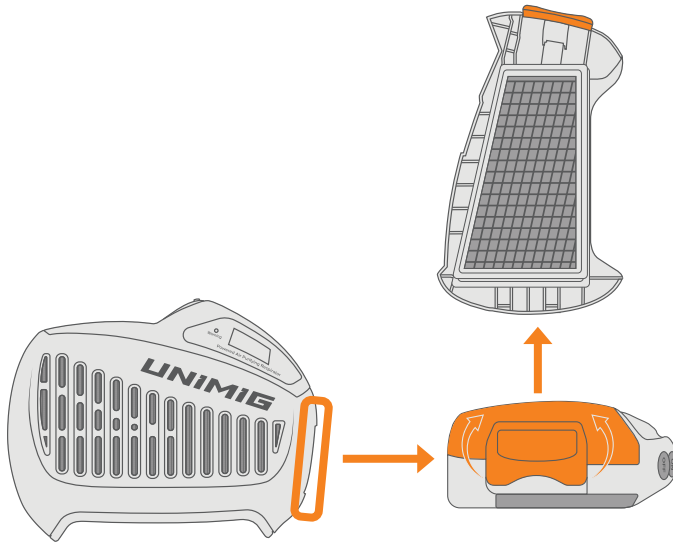

2. Remove the used filter, pre-filter and spark protector by lifting them out from the filter cover.

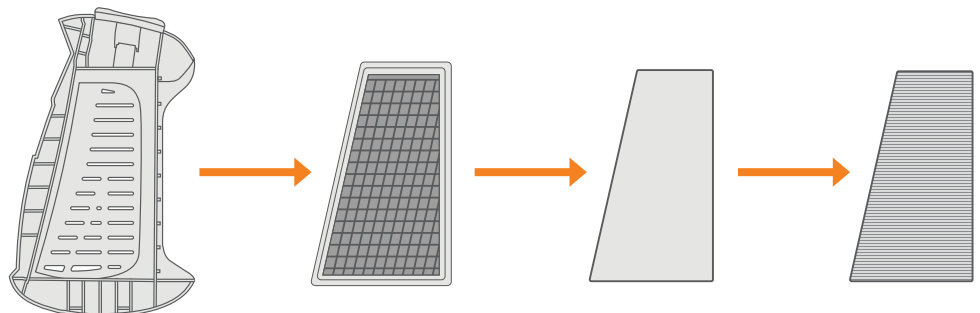

3. If necessary, clean or change the spark protector on the base of the filter cover. Change the pre-filter if needed. Install a new filter in the filter cover.

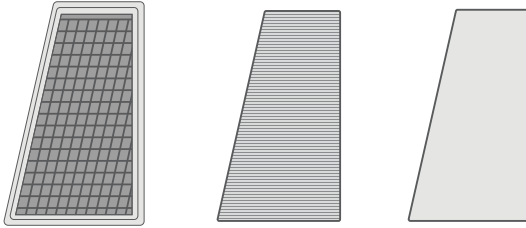

⚠ Caution: Unauthorized filters will void the warranty and expose the user to the risk of personal injury. Do not confuse the markings on a filter relating to any standard other than Australian/New Zealand standard AS/NZS 1716:2012 with the classification PAPR-P3 of U11152 device when used with this filter.

4. Replace the spark protector, pre-filter and filter. Replace the filter cover by hooking the cover on the left side of the blower unit, and pressing the cover down so that the latch engages correctly.

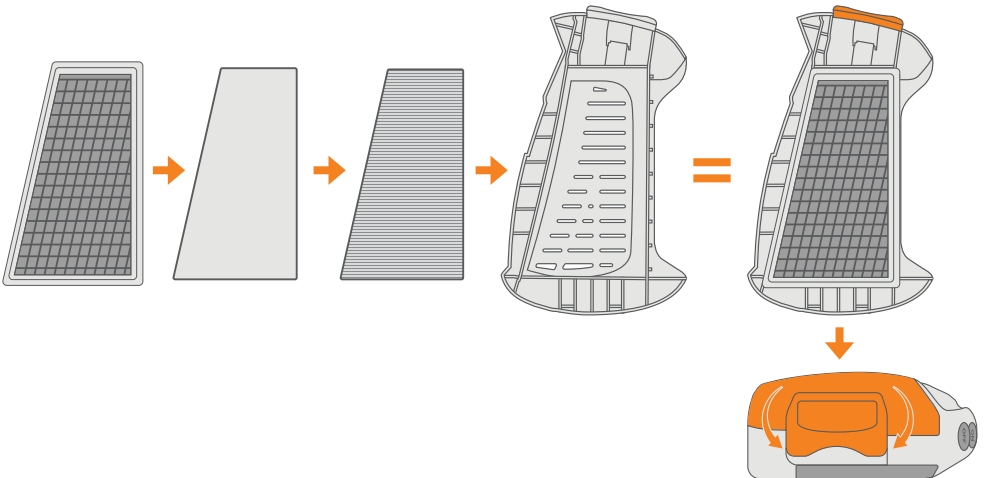

⚠ Warning: Check the expiry date of the unopened filter. **DO NOT USE** if it is expired. Only the U11152 filter, pre-filter, and spark protector can be used together with this system. Filters from other manufacturers should under no circumstances be used.

12. Maintenance & Storage

Inspect the equipment daily, and always check it if any sign of malfunction occurs.

Maintenance

- The blower unit must be checked regularly and must be changed if it is damaged or leaking.
- The filter must be changed if it is broken, or it is blocked and does not give enough airflow.
- The breathing tube must be changed if it is broken or has a crevasse.
- The battery must be charged when the low battery alarm rings.
- Use a soft cloth to wipe the external surfaces. Don't use water!
- The filter should be replaced together with the pre-filter.

Storage

- The PAPR must be stored in a dry, clean area, in the temperature range of -10°C to +55°C and relative humidity less than 90%RH.
- If the equipment is stored at temperature below 0°C, the battery must be allowed to warm up to achieve full battery capacity. The equipment must be protected from dust, particles and other contamination.
- If the equipment is not used for a long time, the battery should be full charged, removed from blower unit and stored separately.

PROBLEM	PROBABLE CAUSE	ACTION
LCD defective code E01 and red light flashes	<p>Motor is stuck</p> <p>Motor damage</p> <p>Blower structure failure caused by outer force</p> <p>Circuit failure</p>	<p>Check and remove physical failure and restart the system. Return to dealer if LCD still shows E01</p>
LCD defective code E02 and red light flashes	<p>Motor damage</p> <p>Motor impeller rubs blower shell</p> <p>Circuit overheating</p>	<p>Check and remove physical failure and restart the system. Return to dealer if LCD still shows E02</p>
<p>LCD battery icon flashes</p> <p>Warning sound</p> <p>Red light flashes</p>	<p>Low battery</p>	<p>Charge the battery</p>
<p>LCD filter icon flashes</p> <p>Warning sound</p> <p>Red light flashes</p>	<p>Filter blocked</p> <p>Breathing tube blocked</p>	<p>Remove obstruction, change the filter</p> <p>Clean breathing tube</p>
<p>LCD temperature icon flashes</p> <p>Warning sound</p> <p>Red light flashes</p>	<p>High temperature</p>	<p>Stop working and rest</p>
No flow, no alarm	<p>1. No power</p> <p>2. Battery contact damaged</p>	<p>Charge the battery</p> <p>Check battery contact</p>
Battery run time is too short	<p>1. Battery is not fully charged</p> <p>2. Filter is blocked</p> <p>3. Battery is damaged</p>	<p>Charge the battery</p> <p>Remove obstruction, Change filter</p> <p>Change battery</p>

PROBLEM	PROBABLE CAUSE	ACTION
Air supply to hood smells unusual	<ol style="list-style-type: none">1. Filter broken2. Breathing tube broken3. ADF helmet broken	<p>Leave current area immediately.</p> <ol style="list-style-type: none">1. Change filter2. Change breathing tube3. Change ADF helmet
Supply insufficient air to hood	<ol style="list-style-type: none">1. Breathing tube break off2. Breathing tube broken3. Filter is blocked	<ol style="list-style-type: none">1. Check breathing tube connect to hood and blower unit2. Change breathing tube3. Remove obstruction, change filter

13. Warning Sound Indication

Each grid stands for a period of 100ms. Grey is the beep sound and blank grid is a quiet period. If several continued grids are in grey then there's a continuous beep sound.

For example, when the current is overloaded, the system sounds like beep~ beep~beep~~~~~.

100ms per grid											
	0	1	2	3	4	5	6	7	8	9	10
Install the battery	Grey	Blank	Blank	Blank	Blank	Blank	Blank	Blank	Blank	Blank	Blank
Turn on the system	Grey	Blank	Blank	Blank	Blank	Blank	Blank	Blank	Blank	Blank	Blank
Change the air flow speed	Grey	Blank	Blank	Blank	Blank	Blank	Blank	Blank	Blank	Blank	Blank
Turn off the system	Grey	Grey	Grey	Grey	Grey	Blank	Blank	Blank	Blank	Blank	Blank
Current overload	Grey	Blank	Grey	Blank	Grey	Grey	Grey	Grey	Grey	Grey	Blank
Air outlet jam	Grey	Blank	Grey	Grey	Grey	Grey	Blank	Blank	Blank	Blank	Blank
Over heat	Grey	Blank	Grey	Blank	Grey	Blank	Grey	Grey	Grey	Grey	Grey
Low battery	Grey	Blank	Grey	Blank	Blank	Blank	Blank	Blank	Blank	Blank	Blank
Filter jam	Grey	Blank	Grey	Blank	Grey	Blank	Blank	Blank	Blank	Blank	Blank



Read instructions before use

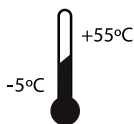

The system should be operated in the temperature range of -5°C to +55°C



The system should be operated in an environment with relative humidity less than 90%RH

14. Warranty

- The blower unit is guaranteed for a period of 12 months from date of purchase against mechanical or electrical defects.
- The U11152 battery is guaranteed for a period of 6 months from the date of purchase.
- The Auto-Darkening Filter (ADF) is guaranteed for a period of 2 years from the date of purchase.
- The company undertakes to exchange or repair without charge, any part found to be defective within this period. Alternatively and at its discretion. The company may replace.

This guarantee is subject to:

- The blower unit has been used solely for the purpose for which it is intended.
- The blower unit has not been subject to misuse, accident, modification or repair.

N.B. In the event of a claim, contact the retailer from which the blower unit was purchased. The guarantee does not cover normal wear and tear this guarantee does not affect your legal rights.

UNiMiG



100%
AUSTRALIAN
OWNED

unimig.com.au

f @ y t @UNiMiG