

UNIMIG RAZOR



SWF 350/500

Contents

1. Safety	3
2. Input Power Requirements	7
2.1 Circuit Breaker Recommendation	8
2.2 Welding Cable Leads Recommendation	9
2.3 Extension Cord Data	9
2.4 Generator Power Data	9
3. Package Contents	10
4. Technical Specifications	11
4.1 RAZOR SWF 350 Machine Specifications	11
4.2 RAZOR SWF 500 Machine Specifications	12
4.3 Equipment Identification	12
4.4 Duty Cycle & Overheating	13
4.4.1 RAZOR SWF 350	13
4.4.2 RAZOR SWF 500	13
4.5 Pinout	14
4.5.1 Power Source	14
4.5.3 Water Cooler Power Port	14
4.5.2 Separate Wire Feeder	14
5. Machine Overview	15
5.1 Key Features	15
5.2 MIG Features	15
5.3 MMA Features	15
5.4 Machine Layout	16
5.5 SWF Module Layout	17
5.6 Water Cooler Module Layout	18
5.7 MIG Torch Digital Module Layout	18
6. Installation	19
6.1 Installing the Separate Wire Feeder (SWF)	19
6.2 Connecting the MIG Torch	23
6.3 Connecting a Spool Gun	27
6.4 Connecting a Push-Pull Gun	28
6.5 Connecting the TIG Torch (optional)	30
6.6 Connecting the MMA Electrode Holder	31
6.7 Connecting the Earth Clamp	32
6.8 Installing & Replacing the Drive Rollers	35
6.9 Installing & Removing the Guide Tube	37
6.10 Installing & Replacing the Wire	38
6.10.1 To Install a Wire Spool	38
6.10.2 Adjusting the Spool Hub Brake	41
6.10.3 To Remove the Wire Spool	41
6.10.4 To Install a Wire Spool in the Spool Gun	42
6.11 Installing & Replacing the Torch Liner	46
6.11.1 Steel Liner	46
6.11.2 Aluminium Liner	49
6.12 Installing the Gas Bottle & Testing the Gas Flow	51
6.12.1 Testing the Gas Flow	52
6.13 Regulator Safety & Operation	53
7. Operation	55
7.1 Preparing for Operation	55
7.2 Control Panel Layout & Operation	56
7.3 MIG Mode	58
7.3.1 Welding Parameters	58
7.3.2 Advanced Welding Parameters	59
7.4 MMA Mode	60
7.4.1 Welding Parameters	60
7.5 TIG Mode	61
7.5.1 Welding Parameters	61
7.6 Job Menu	62
7.6.1 Saving a Job	62
7.6.2 Overwriting a Job	62
7.6.3 Loading a Job	62
7.7 System Settings	63
8. Maintenance	65
9. Troubleshooting	66
9.1 Machine Troubleshooting	66
9.2 MIG Troubleshooting	66
9.3 TIG Troubleshooting	68
9.4 MMA Troubleshooting	69
9.5 Error Codes	70
9.6 Indicator Lights	71
10. General Welding Information	72
10.1 Metal Preparation	72
10.2 Beveling	73
11. MIG Welding Guide	74
12. TIG Welding Guide	81
13. MMA Welding Guide	88
14. Gas Selection	91
14.1 MIG	91
14.2 TIG	91
15. Welding Processes & Features Glossary	92
16. MIG Torch & Consumables	94
16.1 M350 MIG Torch	94
16.2 M350 MIG Torch Consumables	95
16.3 M580W MIG Torch	96
16.4 M580W MIG Torch Consumables	97
17. Recommended Accessories	98

1. Safety

Welding equipment can be dangerous to both the operator and people in or near the surrounding working area if the equipment is not correctly operated. Equipment must only be used under the strict and comprehensive observance of all relevant safety regulations.

Read and understand this instruction manual carefully for all system components, especially the safety instructions and warning notices before the installation and operation of this equipment.

Product specifications and features are subject to change without notice. While every effort has been made to provide accurate and current information at the time of publication, this manual is intended as a general guide and is not exhaustive regarding safety, welding, or the operation and maintenance of this unit. Due to the many variables in the welding field and the evolving nature of both the field and the UNIMIG product line, Welding Guns of Australia Pty Ltd. does not guarantee the accuracy, completeness, authority, or authenticity of the information in this manual or provided by any UNIMIG employee during conversations or business dealings. The product owner assumes all liability for its use and maintenance. Welding Guns of Australia Pty Ltd. does not warrant this product or this document for fitness for any particular purpose, performance, accuracy, or suitability of application. Furthermore, Welding Guns of Australia Pty Ltd. accepts no liability for injury or damages, whether consequential or incidental, resulting from the use of this product or from the content of this document, nor does it accept third-party claims of such liability.

Note:

- Observe the accident prevention regulations and any regional regulations.
- Safety and warning labels on the machine indicate any possible risks.
- Keep these labels clean and legible at all times.
- Technical changes due to further development in machine technology may lead to different welding behaviour.

Items in the manual that require particular attention in order to minimise damage and harm are indicated with the below symbols. Read these sections carefully and follow their instructions.

 **Note:** Gives the user a useful piece of information.

 **Caution:** Describes a situation that may result in damage to the equipment or system.

 **Warning:** Describes a potentially dangerous situation. If not avoided, it will result in personal damage or fatal injury.

Machine Operating Safety

- Do not switch the function modes while the machine is operating. Switching of the function modes during welding can damage the machine. Damage caused in this manner will not be covered under warranty.
- Disconnect the electrode holder cable from the machine before switching on the machine to avoid arcing should the electrode be in contact with the workpiece.
- Only qualified persons should install, operate, maintain, and repair this equipment.
- During operation, keep everyone, especially children, away.



Electric Shock

Electric shock can kill. Touching live electrical parts can cause fatal shocks or severe burns. The electrode and work circuit is electrically live whenever the output is on. The input power circuit and internal machine circuits are also live when power is on. In MIG/MAG welding, the wire, drive rollers, wire feed housing, and all metal parts touching the welding wire are electrically live. Incorrectly installed or improperly grounded equipment is dangerous.

- Connect the primary input cable according to Australian and New Zealand standards and regulations.
- Avoid all contact with live electrical parts of the welding circuit, such as sockets, tungstens and electrodes with bare hands.
- The operator must wear dry, hole-free welding gloves and body protection while they perform the welding task.
- The operator should keep the workpiece insulated from themselves.
- Keep cords dry, free of oil and grease, and protected from hot metal and sparks.
- Frequently inspect input power cable for wear and tear, and replace the cable immediately if damaged. Bare wiring is dangerous and can kill.
- Do not use damaged, undersized, or badly joined cables.
- Do not weld in the rain or in wet, moist, or damp areas.
- Do not drape cables over your body.
- Disconnect power source before servicing or maintaining this equipment.
- We recommend an RCD safety switch is used with this equipment to detect any leakage of current to earth.

⚠ DC voltage remains in the inverter power source after the removal of input power.

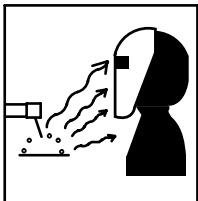

Arc Rays

Arc rays are harmful to your eyes and skin. Arc rays from the welding process produce intense visible and invisible ultraviolet and infrared rays that can burn eyes and skin.

- Always wear an approved welding helmet with the correct shade of filter lens and suitable protective clothing, including welding gloves, while the welding operation is performed.

Recommended filter shades for arc welding

Less than 150A	Shade 10*
150A to 250A	Shade 11*
250A to 300A	Shade 12
300A to 350A	Shade 13
Over 350A	Shade 14

**Use one shade darker for aluminium.*

- Wear safety glasses under your helmet.
- Measures should be taken to protect people in or near the surrounding working area. Use protective screens or barriers to protect others from flash, glare and sparks; warn others not to watch the arc.
- Wear proper PPE and body protection made from durable, flame-resistant materials like leather.

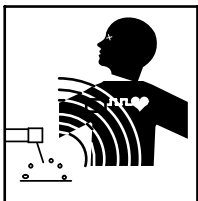

Electro Magnetic Fields (EMF)

Magnetic fields can affect Implanted Medical Devices.

- Wearers of Pacemakers and other Implanted Medical Devices should keep away.
- Implanted Medical Device wearers should consult their doctor and the device manufacturer before going near any arc welding.

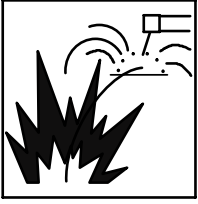

Fire Hazard

Welding on closed containers, such as tanks, drums, or pipes, can cause them to explode. Flying sparks from the welding arc, hot workpiece, and hot equipment can cause fires and burns. Accidental contact of the electrode with metal objects can cause sparks, explosions, overheating, or fire. Check and be sure the area is safe before doing any welding.

- Remove any flammable materials well away from the working area. Cover flammable materials and containers with approved covers if they cannot be moved from the area.
- Do not weld on closed containers or containers that have held combustible materials, such as tanks, drums, or pipes, unless they are correctly prepared according to the required Safety Standards to ensure that flammable or toxic vapours and substances are totally removed, these can cause an explosion even though the vessel has been “cleaned”.
- Vent hollow castings or containers before welding. They may explode.
- Do not weld where the atmosphere may contain flammable dust, gas, or liquid vapours (such as petrol).
- Have a fire extinguisher nearby and know how to use it.
- Be alert that welding sparks and hot materials from welding can easily go through small cracks and openings to adjacent areas.
- Be aware that welding on a ceiling, floor, bulkhead, or partition can cause a fire on the hidden side.
- Avoid welding on tire rims or wheels, as heating can cause tires to explode and repaired rims may fail.
- Attach the earth clamp as close as possible to the welding area to minimise the risk of electric shock, sparks, and fire hazards caused by the welding current travelling through long or unknown paths.
- When not in use, ensure the MMA electrode is removed from its holder.
- Before welding, remove any combustible items, like butane lighters or matches, from your person.
- Post welding, thoroughly inspect the area to ensure there are no lingering sparks, glowing embers, or flames.
- Always use the correct fuses or circuit breakers, and don't oversize or bypass them.
- Wear proper PPE and body protection made from durable, flame-resistant materials like leather.
- Read and understand the Safety Data Sheets (SDSs) and the manufacturer's instructions for adhesives, coatings, cleaners, consumables, coolants, degreasers, fluxes, and metals.



Hot Parts

Hot parts can burn. Items being welded can generate and hold high heat and can cause severe burns.

- Do not touch hot parts with bare hands.
- Allow a cooling period before working on the welding equipment.
- Use the proper tools and insulated welding gloves and clothing to handle hot parts and prevent burns.



Noise Hazards

The noise from some processes or equipment can damage hearing.

- Wear approved ear protection if the noise level is high.



Gas Cylinders

Shielding gas cylinders contain gas under high pressure. If damaged, a cylinder can explode. Because gas cylinders are usually part of the welding process, be sure to treat them carefully.

- Protect gas cylinders from excessive heat, mechanical shocks, physical damage, slag, open flames, sparks, and arcs.
- Ensure cylinders are secured upright to prevent tipping or falling over.
- Never allow the welding electrode, earth clamp, or electrical circuit to touch the gas cylinder, and don't drape welding cables over the cylinder.
- Never weld on a pressurised gas cylinder, it will explode and kill you.
- Open the cylinder valve slowly and turn your face away from the cylinder outlet valve and gas regulator. Stand to the side of the cylinder when opening the valve.
- Only use the correct gas, regulators, hoses, and fittings for your application and keep them in good condition.
- Keep full and empty cylinders separate.
- Keep ammonia-based leak detection solutions, oil and grease away from cylinders and valves.
- Never use force when opening or closing valves.
- Don't repaint or disguise markings and damage. If damaged, return cylinders immediately.
- When working with cylinders or operating cylinder valves, ensure that you wear appropriate protective clothing – gloves, boots and safety glasses.

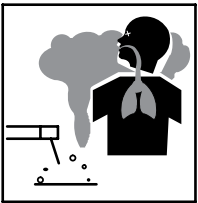

Fumes & Gases

Fumes and gases are dangerous. Welding produces fumes and gases and breathing these fumes and gases can be hazardous to your health.

- Do not breathe the smoke and gas generated while welding. Keep your head out of the fumes.
- Keep the working area well-ventilated and use fume extraction or ventilation to remove welding fumes and gases.
- In confined or heavy fume environments, always wear an approved air-supplied respirator.
- Welding fumes and gases can displace air and lower the oxygen level, causing injury or death. Be sure the breathing air is safe.
- Do not weld in locations near degreasing, cleaning, or spraying operations. The heat and rays of the arc can react with vapours to form highly toxic and irritating gases.
- Materials such as galvanised, lead, or cadmium-plated steel contain elements that can give off toxic fumes when welded. Do not weld these materials unless the coating is removed, or the area is very well-ventilated and/or you are wearing an air-supplied respirator.
- Read and understand the Safety Data Sheets (SDSs) and the manufacturer's instructions for adhesives, coatings, cleaners, consumables, coolants, degreasers, fluxes, and metals.

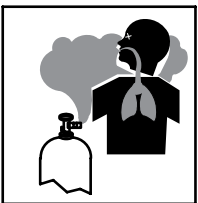

Gas Buildup

The build-up of gas can cause a toxic environment and deplete the oxygen content in the air resulting in death or injury. Many gases used in welding are invisible and odourless.

- Shut off the shielding gas supply when not in use.
- Always ventilate confined spaces or use an approved air-supplied respirator.



PLEASE NOTE that under no circumstances should any equipment or parts be altered or changed in any way from the standard specification without written permission given by UNIMIG.

To do so will void the warranty.

2. Input Power Requirements

UNIMIG welding machines are designed and manufactured to conform to **IEC 60974** or **AS 60974** standards. This Standard covers the safety and performance requirements of welding power sources and plasma cutting systems. This includes the **machine**, the **input cable**, and the **plug** requirements like the size of the plug that should be used.

Maximum effective supply current (I_{eff}) according to AS 60974.1

$$I_{\text{eff}} = \sqrt{I_1^2 \times X + I_0^2(1-X)}$$

I_0 Rated no-load supply current

I_1 Rated supply current

X Rated duty cycle

The I_{eff} identifies the appropriate plug, input cable, and input current necessary for each device.

	Min-Max Cable Size
$I_{\text{eff}} \leq 10\text{A}$	1.5-2.5mm ²
$I_{\text{eff}} \leq 15\text{A}$	1.5-4.0mm ²
$I_{\text{eff}} \leq 25\text{A}$	2.5-6.0mm ²
$I_{\text{eff}} \leq 32\text{A}$	4.0-10.0mm ²

⚠ Don't risk damage to your machine or cause tripping and/or fire by using the wrong input current, cable or plug. Don't tamper with the plugs or file down earth pins. Doing so will void your warranty.

For your safety, UNIMIG meets the AS/NZS Standards for safe electrical compliance

All UNIMIG machines undergo an independent certification process to meet Australian and New Zealand regulations regarding electrical safety.



The triangle-circle-tick (RCM) symbol signifies that UNIMIG has taken the necessary steps to have the product comply with the electrical safety and/or electromagnetic compatibility (EMC) legislative requirements as specified by the Electrical Regulatory Authorities Council (ERAC). For your safety, please check for this symbol before buying any welding machine in Australia and New Zealand.

Check the rating plate on your machine

All welding machines that comply with **IEC 60974** or **AS 60974** must have a data plate similar to the one shown.







Welding machines draw some current when not welding, a higher current when welding, and a surge current when initiating an arc.

The effective rated primary current (I_{eff}) combines the conductor heating due to these levels of current. I_{eff} is the maximum rated effective supply current that determines the minimum plug and input cable rating as well as the minimum capacity of the input circuit that the machine gets plugged into to safely operate the machine.







Look for the I_{eff} on the welding machine's rating plate and ensure that you have the correct input circuit to support this power draw.

Example: If the I_{eff} rating on your machine is 27A then you must use a 32A plug, as a 15A plug is undersized for the welding current being used and may cause the cable to overheat.

RAZOR SWF 350 Data Plate

		 U_0 75V	30A/15.5V~350A/31.5V				 U_0 75V U_r 13V	20A/10.8V~350A/24V				IP23S Insulation class:H MADE IN CHINA	
			X	50%	60%	100%		X	50%	60%	100%		
RAZOR SWF 350 U11213  AS 60974.1	 U_0 75V U_r 13V	20A/20.8V~350A/34V				 U_1 415V 3~ 50/60Hz	I_{1max} MIG 25.0A MMA 25.0A TIG 18.9A		I_{1eff} 13.9A 15.0A 10.7A		Welding Guns of Australia Pty Ltd Address: 112 Christina Rd Villawood NSW 2163 AUSTRALIA		
		X	50%	60%	100%		X	50%	60%	100%			

RAZOR SWF 500 Data Plate

		 U_0 82V	30A/15.5V~500A/39V				 U_0 82V U_r 13V	20A/10.8V~500A/30V				IP23S Insulation class:H MADE IN CHINA	
			X	40%	60%	100%		X	40%	60%	100%		
RAZOR SWF 500 U11214  AS 60974.1	 U_0 82V U_r 13V	20A/20.8V~500A/40V				 U_1 400V 3~ 50/60Hz	I_{1max} MIG 42.8A MMA 40.1A TIG 33.4A		I_{1eff} 22.0A 22.6A 17.1A		Welding Guns of Australia Pty Ltd Address: 112 Christina Rd Villawood NSW 2163 AUSTRALIA		
		X	40%	60%	100%		X	40%	60%	100%			

How important is the correct input cable and plug on a welding machine?

The size of the plug depends on the above formula, which uses the maximum current draw as well as the duty cycle of the power source. The use of any welding power source will not only cause the machine itself to heat up but the input cable, plug, and mains power as well.

That's why it's important to understand input and output currents and to make sure that the input circuit is correctly rated to supply the required input draw. This allows the machine to operate at or near maximum output and protects the circuit board from tripping, overheating and/or catching fire.

What if I don't have a 415volt outlet?

If you don't have a suitable power outlet, you should contact a qualified electrician to advise whether the wiring in your building will cater the necessary outlet. You may also need to upgrade your circuit breakers and possibly switchboard to suit. Failure to do this may cause an electrical fire in the building which may void insurances.

Make sure you:

- ✓ Use the correct input current cable and plug in accordance with **AS 60974.1** for your safety and to get the maximum performance from your welding machine.
- ✓ Inspect cables and plugs regularly.
- ✓ Contact a qualified electrician for advice and/or upgrade and, if needed, to replace any damaged plugs or cables.

2.1 Circuit Breaker Recommendation

The maximum input current (I_{max}) will determine the size of the circuit breaker that should be installed in order to run the machine continuously without risk of voltage drops from the circuit breaker to the plug outlet.

The recommended circuit breaker for this machine is 32A.

This recommendation is distinct from the effective current (I_{1eff}), which dictates the size of the input plug.

2.2 Welding Cable Leads Recommendation

Welding cables are crucial electrical conductors for the welding current. The appropriate thickness of the welding cable is dictated by the machine's maximum amperage and the length of cable needed. It is essential that both the earth clamp and the electrode holder are equipped with adequately sized welding cable leads to maintain effective operation.

Current (A)	Duty Cycle (%)	Lead thickness (mm ²) based off combined lengths of electrode and earth cable				
		Up to 15m	16-30m	31-45m	46-60m	61-75m
125	30	10	16	25	35	50
150	40	10	16	25	35	50
180	30	25	25	35	50	50
200	60	35	35	35	50	50
225	30	25	25	50	50	50
250	30	25	25	50	50	50
275	60	50	50	50	70	95
300	60	50	50	70	70	95
350	60	50	50	70	95	120
400	100	70	70	95	95	120
500	100	70	95	95	95	120

2.3 Extension Cord Data

See the table below as a guide based on the minimum necessary input power (in this case, 20A):

Cord thickness/Cable size (mm ²)	Maximum length of cord (m)
2.5	30
4.0	50

Using an extension lead that is too small, or using it over a longer distance than recommended, will lead to voltage drops and cause problems with power supply.

⚠ Not following these recommendations can cause insufficient power, which can lead to unstable arc behaviour, reduced penetration, and poor weld quality.

2.4 Generator Power Data

Operate these units only with clean power generators that provide a surge capacity of 23,000 watts or more for the RAZOR SWF 350 and a surge capacity of 40,000 watts or more for the RAZOR SWF 500.

The generator should limit Total Harmonic Distortion (THD) to 5% or below, as this level of THD is deemed 'clean' and comparable to conventional shop power. Usage of generators that don't meet the clean power standard (5% or lower THD) is not recommended.

⚠ Not following these recommendations can cause insufficient power, which can lead to unstable arc behaviour, reduced penetration, and poor weld quality. In some instances it can also cause damage to your equipment.

3. Package Contents

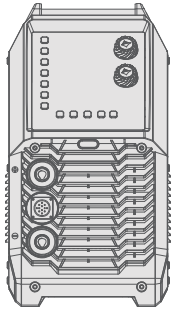

**RAZOR SWF 350/500
Power Source**

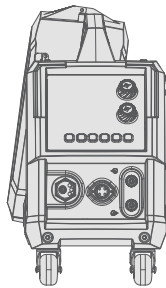

Separate Wire Feeder

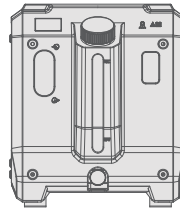

**Tool Drawer OR
Water Cooler**

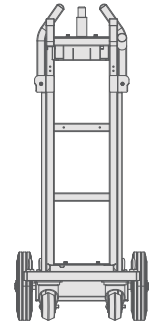

Trolley

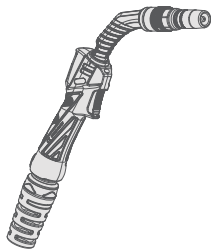

**3m M350 MIG Torch OR
3m M580W MIG Torch**

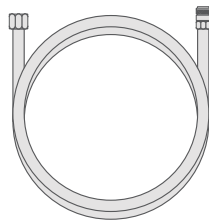

**Quick-Connect
Gas Hose**

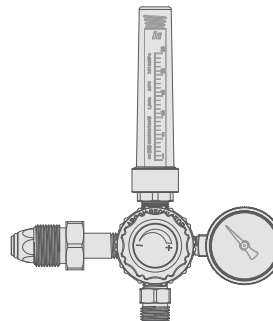

**Dual Stage Argon
Flowmeter**

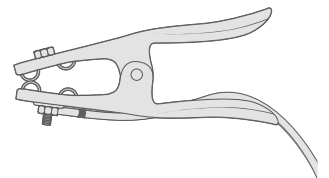

500A Earth Clamp

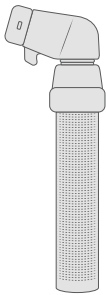

500A Electrode Holder

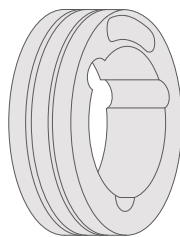

37/24 Rollers

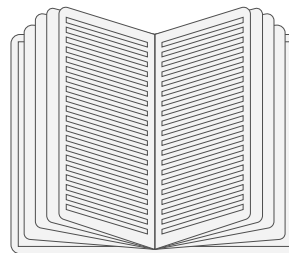

Manual

Includes:

- 4 x 1.0-1.2mm U Groove
- 2 x 0.8-0.9mm V Groove
- 2 x 1.0-1.2mm V Groove
- 2 x 0.8-0.9mm F Groove
- 2 x 1.0-1.2mm F Groove

4. Technical Specifications

4.1 RAZOR SWF 350 Machine Specifications

Technical Data

Parameter	Values
SKU	U11213
Primary Input Voltage	415V Three-Phase
Supply Plug	Unplugged (32A Recommended)
I _{eff} (A)	13.9
I _{max} (A)	25.0
Rated Output	20-350A
No Load Voltage (V)	75
Protection Class	IP23S
Insulation Class	H
Minimum Generator (kVA)	23
Dinse Connector	35/50
Standard	AS 60974.1
Welds	<p>MIG: Mild Steel, Stainless Steel, Aluminium, Silicon Bronze</p> <p>MMA: Mild Steel, Stainless Steel, Cast Iron</p> <p>TIG: Mild Steel, Stainless Steel, Copper, Silicon Bronze</p>
Warranty (Years)	5

MIG Specifications

Parameter	Values
MIG Welding Current Range	30-350A
MIG Duty Cycle @ 40°C	50% @ 350A 60% @ 319A 100% @ 247A
MIG Wire Size Range	0.6-1.2mm
MIG Wire Spool Size	5kg (200mm) / 15kg (300mm)
MIG Welding Thickness Range	1-16mm
Drive Roller Size	37/24

TIG Specifications

Parameter	Values
TIG Function Type	DC Lift Arc
TIG Welding Current Range	20-350A
TIG Duty Cycle @ 40°C	50% @ 350A 60% @ 319A 100% @ 247A
TIG Welding Thickness Range	1-10mm

MMA Specifications

Parameter	Values
STICK Welding Current Range	20-350A
STICK Duty Cycle @ 40°C	50% @ 350A 60% @ 319A 100% @ 247A
STICK Electrode Range	2.5-4.0mm
STICK Welding Thickness Range	2-16mm

Size & Weight

Parameter	Values
Dimensions (mm)	1520x520x980
Power Source Weight (kg)	27.21
Separate Wire Feeder Weight (kg)	17.8
Trolley With Drawer Weight (kg)	43.4

4.2 RAZOR SWF 500 Machine Specifications

Technical Data

Parameter	Values
SKU	U11214 (Air-Cooled) U11234 (Water-Cooled)
Primary Input Voltage	415V Three-Phase
Supply Plug	Unplugged (32A Recommended)
I_{eff} (A)	22.0
I_{max} (A)	42.8
Rated Output	20-500A
No Load Voltage (V)	82
Protection Class	IP23S
Insulation Class	H
Minimum Generator (kVA)	40
Dinse Connector	35/50
Standard	AS 60974.1
Welds	MIG: Mild Steel, Stainless Steel, Aluminium, Silicon Bronze MMA: Mild Steel, Stainless Steel, Cast Iron TIG: Mild Steel, Stainless Steel, Copper, Silicon Bronze
Warranty (Years)	5

MIG Specifications

Parameter	Values
MIG Welding Current Range	30-500A
MIG Duty Cycle @ 40°C	40% @ 500A 60% @ 408A 100% @ 316A
MIG Wire Size Range	0.8-1.6mm
MIG Wire Spool Size	5kg (200mm) / 15kg (300mm)
MIG Welding Thickness Range	1-30mm
Drive Roller Size	37/24

TIG Specifications

Parameter	Values
TIG Function Type	DC Lift Arc
TIG Welding Current Range	20-500A
TIG Duty Cycle @ 40°C	40% @ 500A 60% @ 408A 100% @ 316A
TIG Welding Thickness Range	1-10mm

MMA Specifications

Parameter	Values
STICK Welding Current Range	10-500A
STICK Duty Cycle @ 40°C	40% @ 500A 60% @ 408A 100% @ 316A
STICK Electrode Range	2.5-6.0mm
STICK Welding Thickness Range	2-20mm

Size & Weight

Parameter	Values
Dimensions (mm)	1520x520x980mm
Power Source Weight (kg)	30
Separate Wire Feeder Weight (kg)	17.8
Trolley With Drawer Weight (kg)	43.4
Trolley With Water Cooler Weight (kg)	46.85

4.3 Equipment Identification

Serial Number

The serial number of the device is marked below the data plate on the back of the power source. It is important to make correct reference to the serial number of the product when ordering spare parts or making repairs, for example.

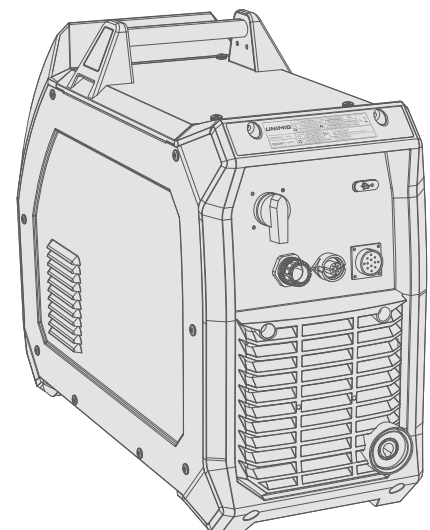

4.4 Duty Cycle & Overheating

The duty cycle is how long a machine can continuously weld at a selected amperage over a 10-minute period before the thermal overload protection kicks in.

4.4.1 RAZOR SWF 350

MIG - 50% @ 350A, at 40°C ambient temperature



TIG - 50% @ 350A, at 40°C ambient temperature



MMA - 50% @ 350A, at 40°C ambient temperature



4.4.2 RAZOR SWF 500

MIG - 40% @ 500A, at 40°C ambient temperature



TIG - 40% @ 500A, at 40°C ambient temperature



MMA - 40% @ 500A, at 40°C ambient temperature



4.5 Pinout

4.5.1 Power Source

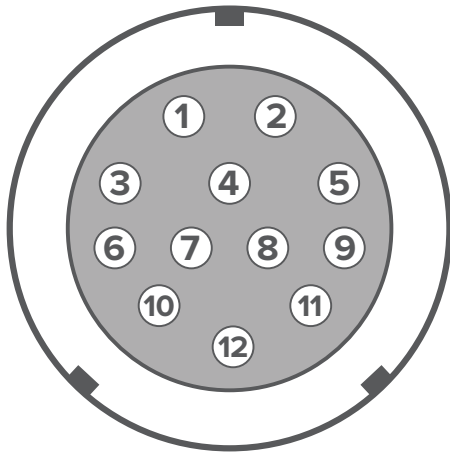

PIN Number	Function
1	+24V
2	Ground (GND)
3	CANH (CAN High)
4	CANL (CAN Low)
5	CAN Ground (GND)
6	Motor (+)
7	Motor (-)
8	Trigger Signal Ground (GND)
9	Gas Valve Power Supply (+)
10	Trigger Line
12	Wire Feeder Voltage Feedback Signal

4.5.2 Separate Wire Feeder

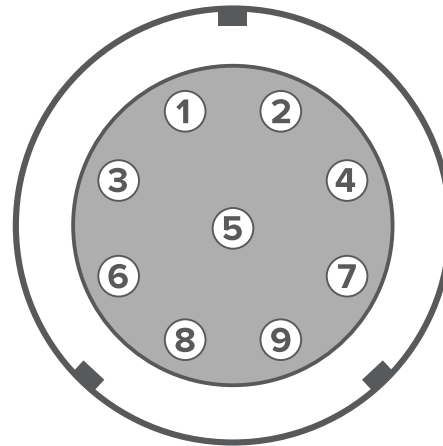

PIN Number	Function
1	VCC 3.3V
2	Simulated Torch Signal Input (GUN_ctrl)
3	Torch Signal Ground (GND)
7	Motor (+)
8	Motor (-)

4.5.3 Water Cooler Power Port

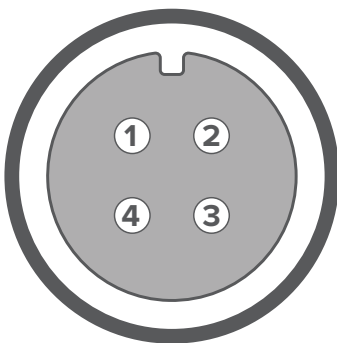

PIN Number	Function
1	Power Line A
2	Power Line B
3	Signal Detection
4	Ground To Machine Steel Case (GND)

5. Machine Overview

5.1 Key Features

HD Backlit Interface

This next generation interface panel is bright and easy to read in any environment.

Multi-Process Welding

Get the job done quickly and efficiently with our versatile three-in-one welding machine. With the ability to perform MIG, TIG, and STICK welding all in one unit, you can save valuable time and effort without sacrificing quality.

4 Geared Wire Drive

The most consistent and smoothest wire-feeding experience there is. With a four geared wire drive unit, there's more power pushing the wire, improving the wire feeding, especially in longer torches.

Large Wire Spool Capacity

Fits both D200 and D300 wire spools, so you can put 15kg mild steel or 7kg aluminium spools in the machine.

Separate Wire Feeder

Get the ultimate flexibility. The addition of a separate wire feeder means you can detach the wire feeder from the main power source, giving you an extra 10m of manoeuvrability.

Job Memory

The job memory function allows you to enter and store weld parameter settings. Weld parameters can be further adjusted and stored as required. A total of 10 jobs can be memorised and stored for recall.

Smart Fan

Smart Fan diminishes noise, saves power, helps reduce energy costs, and minimises the number of contaminants being pulled through the machine.

Generator Compatible

Going off the grid? The RAZOR SWF 350 & 500 can be connected to a generator. We recommend one with at least 23kVA for the RAZOR SWF 350 and 40kVA for the RAZOR SWF 500.

IP23S Rating

Rated IP23S, so it's protected from touch by fingers and objects greater than 12mm, and water spray less than 60° from vertical.

Trigger Controlled DC Lift Arc TIG

The Trigger Controlled DC Lift Arc ignition allows the arc to be started easily in DC TIG by simply touching the tungsten to the workpiece and lifting it up to start the arc. This stops the tungsten tip sticking to the workpiece and breaking the tip from the tungsten electrode.

5.2 MIG Features

Smart-Set MIG

Getting set up for a weld has never been faster with our preset synergic programs. Simply select your wire type, wire size, gas type and material thickness, and the machine does the rest. It'll pick the optimal settings for your weld.

Gas & Gasless MIG

Capable of running both gas-shielded and gasless MIG wire, you can tackle a wide variety of welding projects with ease. Whether you're working with mild steel, stainless steel, aluminium, or flux-cored wire, our machine has got you covered.

Digital Control MIG Torch

Our digital MIG torch allows you to adjust your settings on the fly. No more hassle of constantly adjusting your settings on a separate control panel. With our leading technology, you can easily fine-tune the amps, current and voltage at the touch of a torch button.

Spool Gun Ready

Make welding aluminium even easier. No need to change your existing setup. The spool gun lets you quickly switch over and get any job done with no downtime.

Push-Pull Gun Ready

Achieve smooth and steady wire feeding, especially when using softer wires such as aluminium. With a 'Pull' motor built into the torch, the wire can be fed over a greater distance, granting you the freedom to move and manoeuvre with ease while MIG welding.

5.3 MMA Features

Arc Force

The Arc Force feature helps to keep the arc stabilised throughout the weld, by increasing or decreasing the peak current to compensate for your arc length, preventing the arc from cutting out or the electrode from sticking.

Anti Stick

The Anti Stick feature, which is always on, prevents your electrode from sticking to your workpiece. When the machine detects sticking, the current will drop significantly, so the electrode can be removed.

5.4 Machine Layout

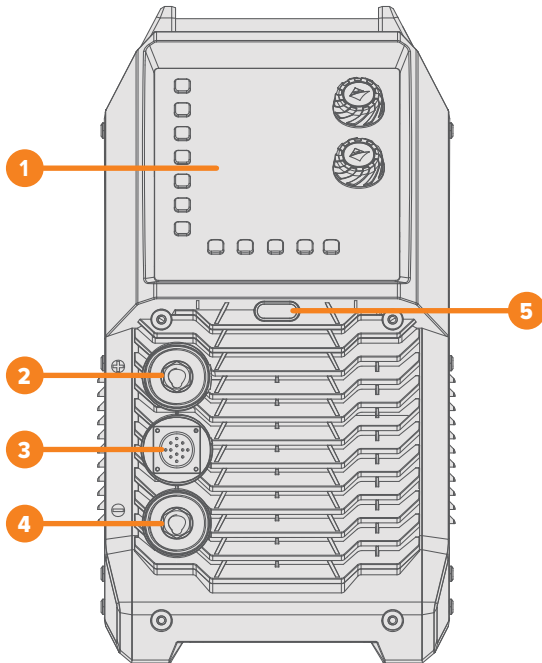

Front Panel Layout

1. Display Panel
2. Positive Dinse Connector (+)
3. 12 Pin Outlet
4. Negative Dinse Connector (-)
5. Remote Connection Indicator

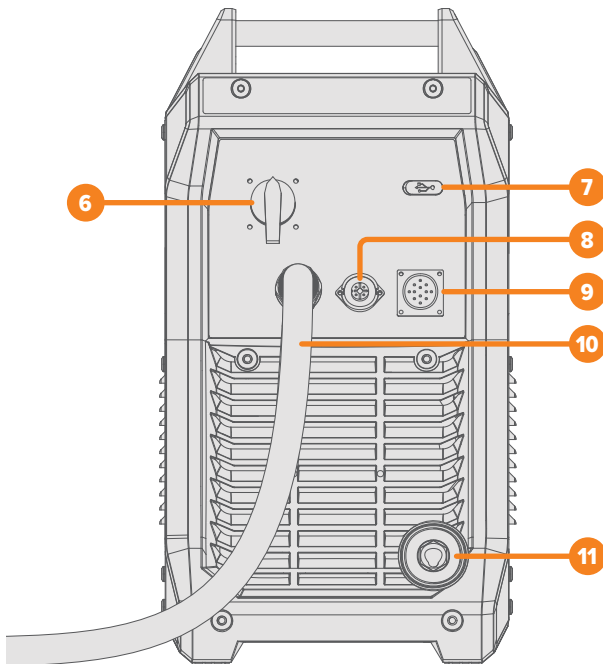

Back Panel Layout

6. Power Switch
7. USB-C Port
8. Water Cooler Connection
9. SWF Interconnecting Cable Plug
10. Power Cable
11. SWF Interconnecting Dinse

5.5 SWF Module Layout

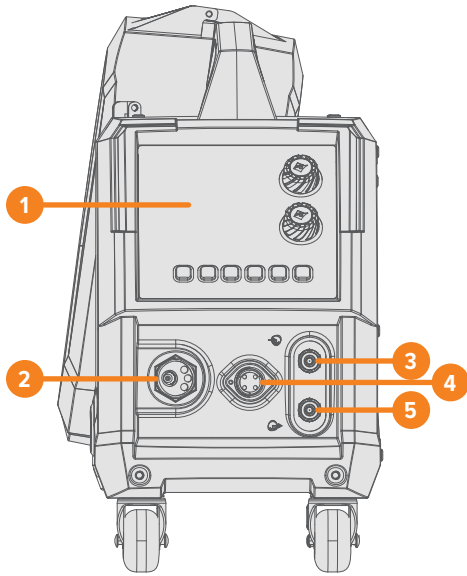

Front Panel Layout

1. Display Panel
2. Euro Connection
3. Coolant Return Connection (Red)
4. 9 Pin Outlet
5. Coolant Flow Connection (Blue)

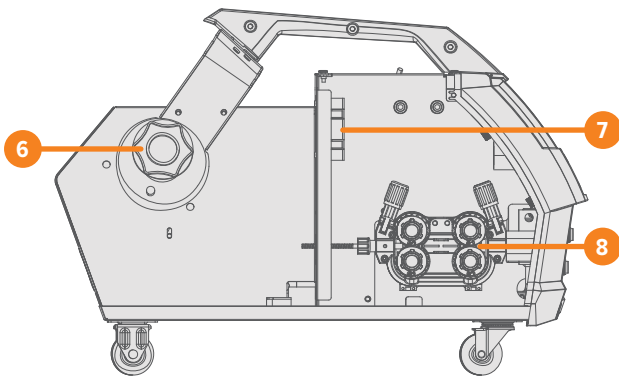

Wire Spool Side Panel Layout

6. Wire Spool Holder
7. Drive Roller Holder
8. 4 Geared Wire Drive

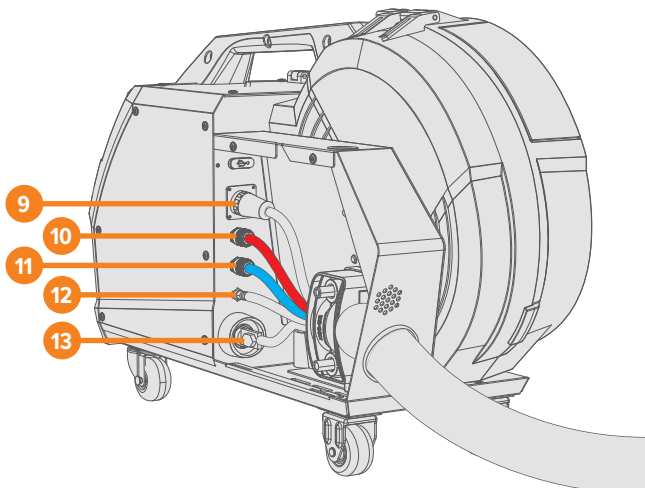

Interconnecting Side Panel Layout

9. Interconnecting Power Cable
10. Interconnecting Coolant Return Connection (Red)
11. Interconnecting Coolant Flow Connection (Blue)
12. Interconnecting Gas Inlet
13. Interconnecting Dinse Connector

5.6 Water Cooler Module Layout

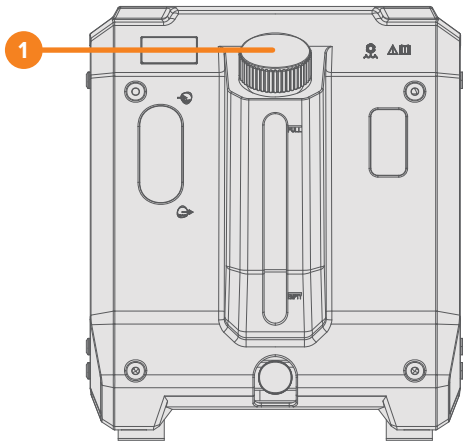

Front Panel Layout

1. Coolant Fill Port

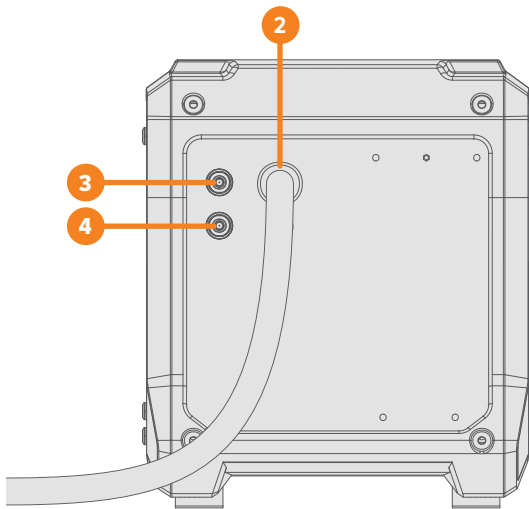

Back Panel Layout

2. Water Cooler Connection Port
3. Coolant Return Connection (Red)
4. Coolant Flow Connection (Blue)

5.7 MIG Torch Digital Module Layout

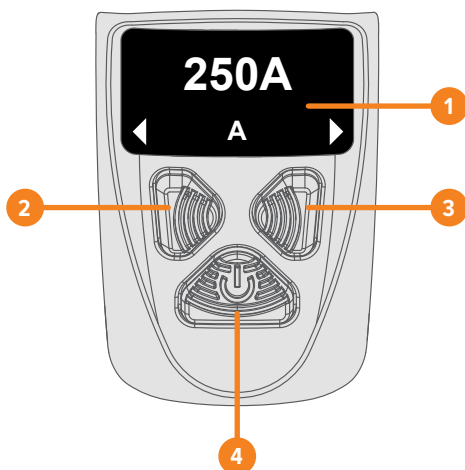

Front Panel Layout

1. LED Display
2. Decrease Selected Parameter (-)
3. Increase Selected Parameter (+)
4. Cycle Parameters

6. Installation

⚠ Don't connect the equipment to the wall socket/mains supply before the installation is complete.

⚠ Don't modify the equipment in any way except for the changes and adjustments covered in the manufacturer's instructions.

ℹ Place the machine on a horizontal, stable and clean ground. Check that there is enough space for cooling air circulation in the machine's vicinity. Don't cover the machine's ventilation as it could overheat.

6.1 Installing the Separate Wire Feeder (SWF)

Mounting the Separate Wire Feeder

Line up the locating pin with the bottom of the Separate Wire Feeder and place it on the machine.

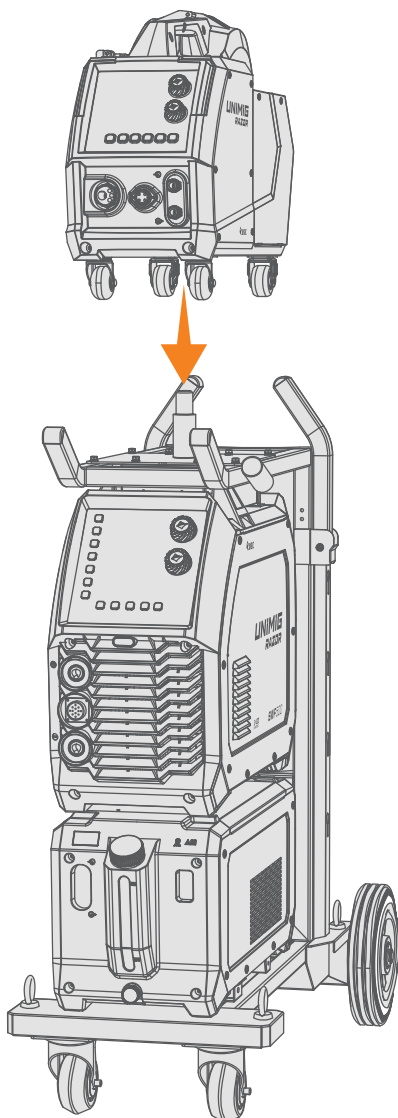

Installing the Interconnecting Cables

Inside the Separate Wire Feeder (SWF)

Air-Cooled

1. Remove the side panel from the Separate Wire Feeder.
2. Cut an X into the back rubber panel to feed the cables through into the SWF unit.
3. Plug the gas hose into the gas connection and the interconnecting cable into the pin socket.

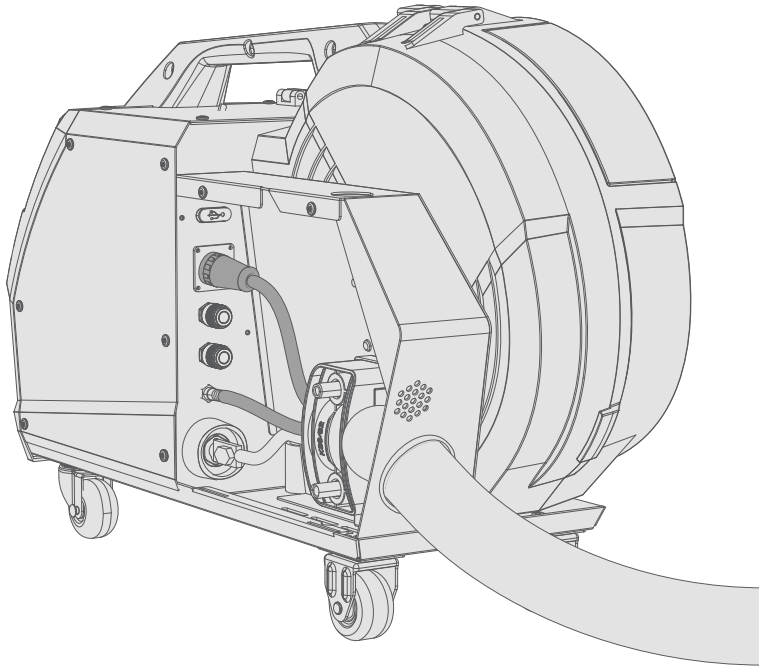

Water-Cooled

4. Plug the red coolant return cable into the red output connection and the blue coolant supply cable into the blue input connection on the front of the separate wire feeder unit.

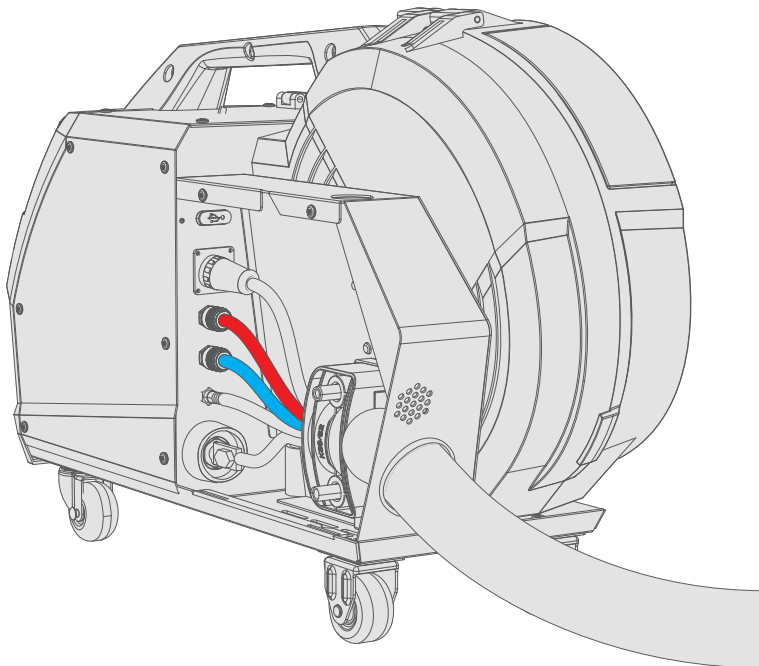

On the Power Source

Air-Cooled

1. Plug the gas hose into the gas cylinder.
2. Connect the interconnecting cable into the pin socket on the back of the power source.

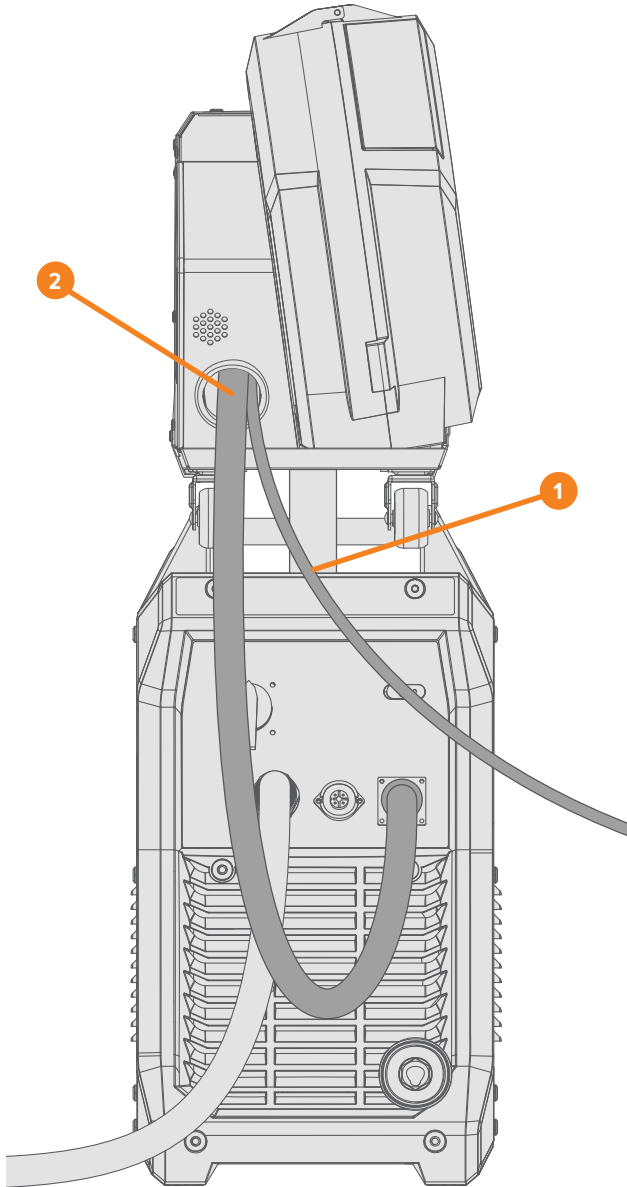

Water-Cooled

3. Plug the red coolant return cable into the red output connection and the blue coolant supply cable into the blue input connection on the back of the water cooler.

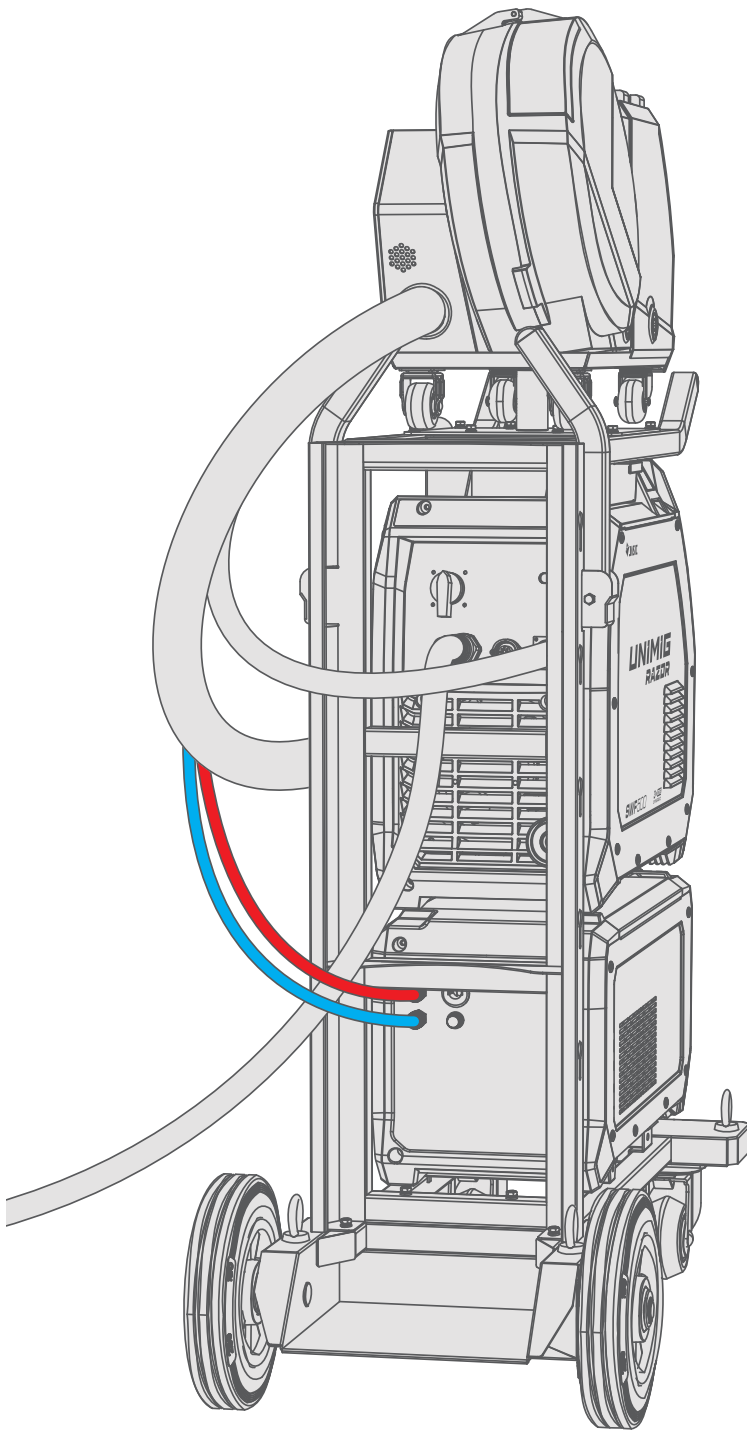

6.2 Connecting the MIG Torch

Air-Cooled

Gas-Shielded MIG

1. Connect the MIG torch into the Euro connection and twist the end to secure it in place.
2. Connect the dinse plug into the positive (+) dinse connection on the front of the machine.

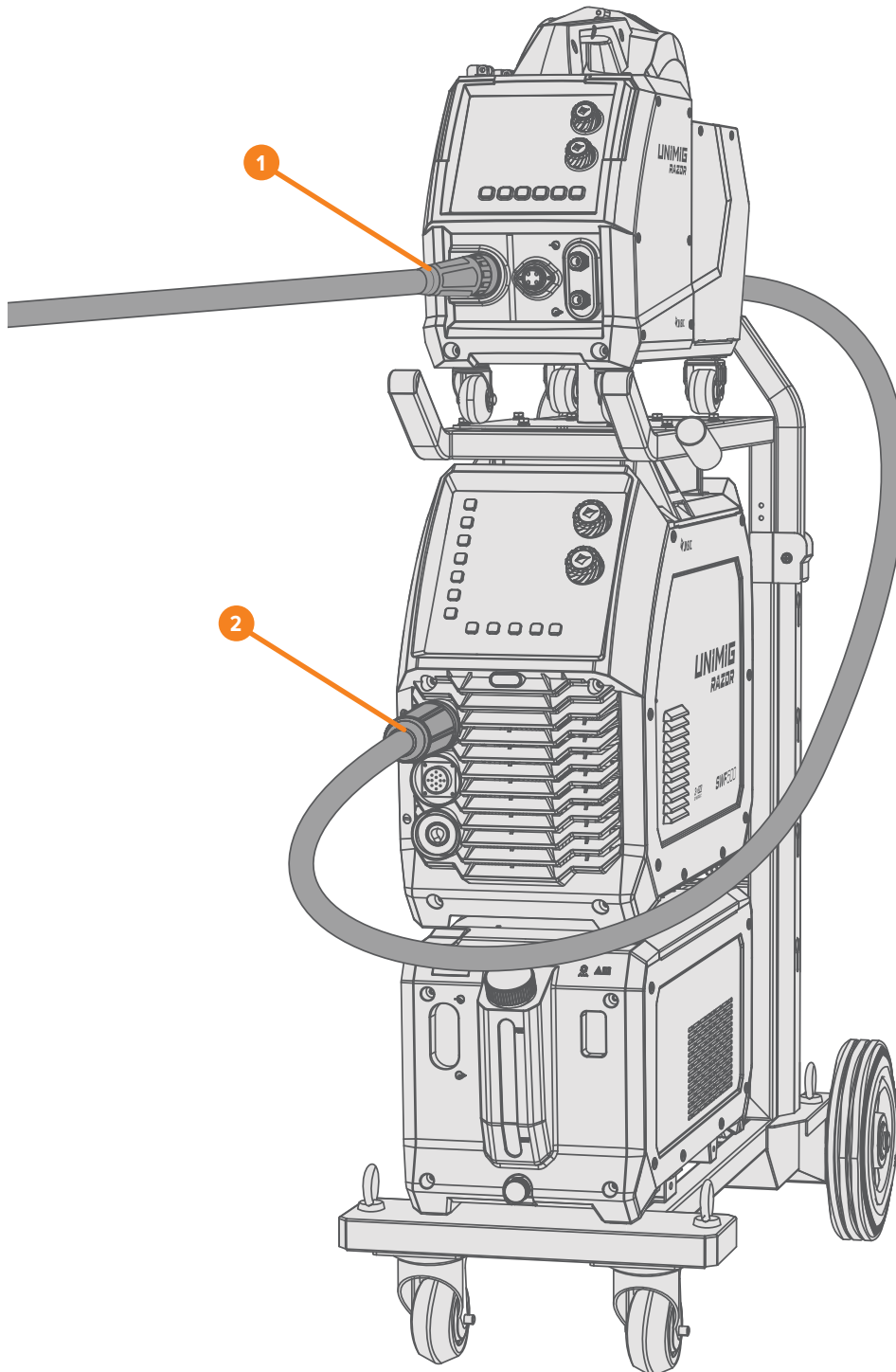

Gasless MIG

1. Connect the MIG torch into the Euro connection and twist the end to secure it in place.
2. Connect the dinse plug into the negative (-) dinse connection on the front of the machine.

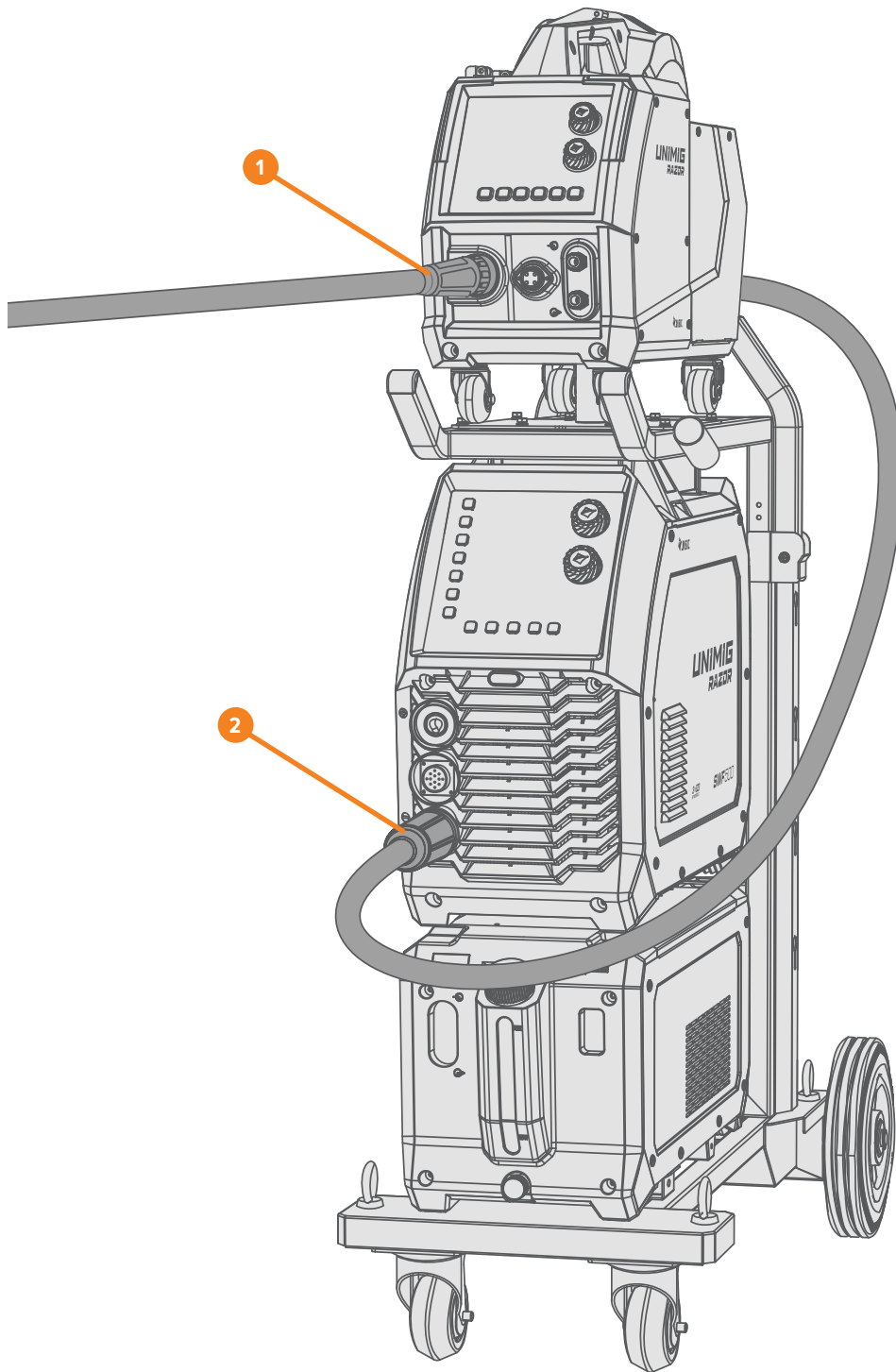

Water-Cooled Gas-Shielded MIG

1. Connect the MIG torch into the Euro connection and twist the end to secure it in place.
2. Connect the dinse plug into the positive (+) dinse connection on the front of the machine.
3. Plug the red coolant return cable into the red output connection and the blue coolant supply cable into the blue input connection on the front of the separate wire feeder unit.

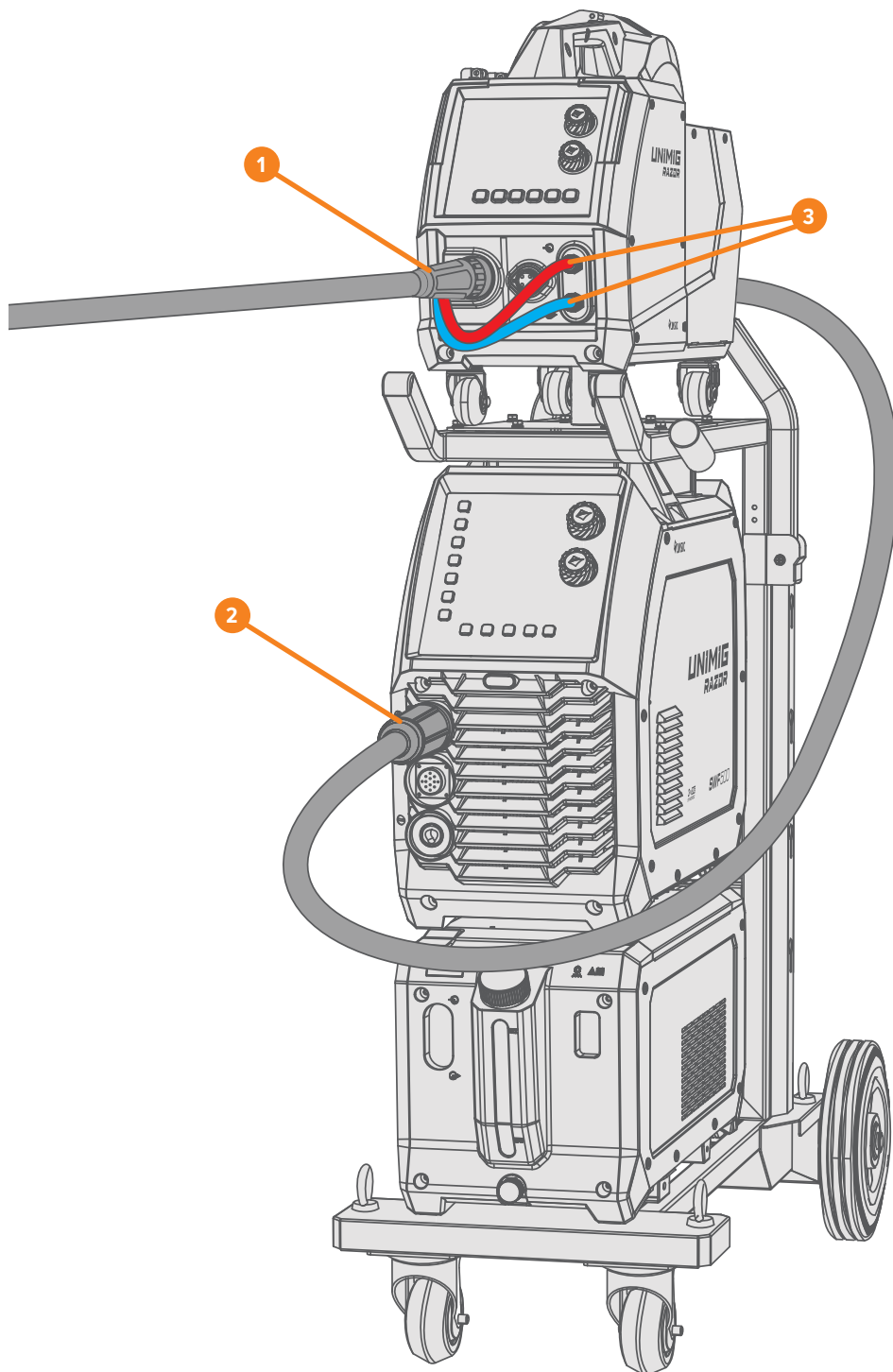

Gasless MIG

1. Connect the MIG torch into the Euro connection and twist the end to secure it in place.
2. Connect the dinse plug into the negative (-) dinse connection on the front of the machine.
3. Plug the red coolant return cable into the red output connection and the blue coolant supply cable into the blue input connection on the front of the separate wire feeder unit.

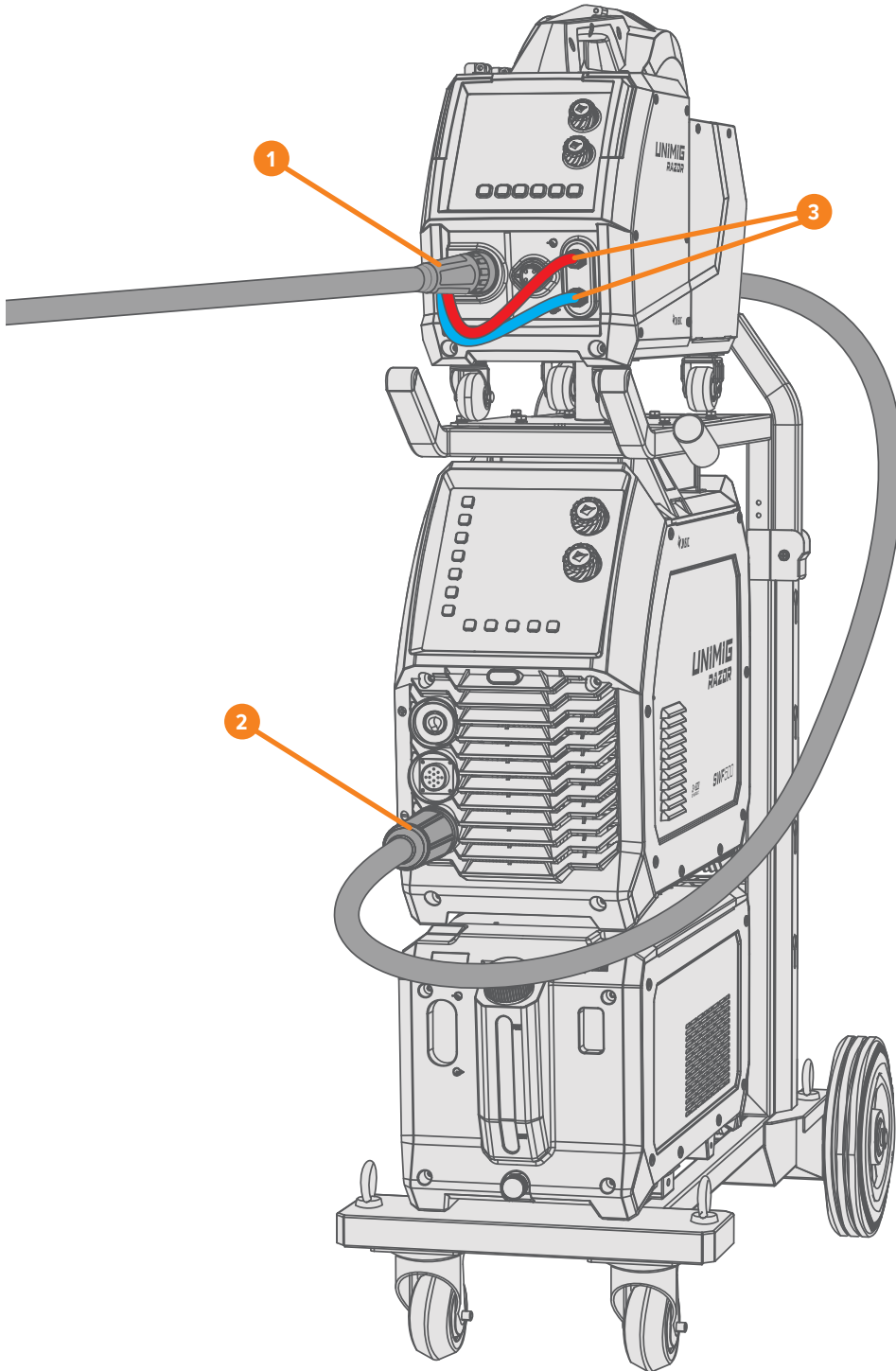

6.3 Connecting a Spool Gun

1. Connect the spool gun into the Euro connection and twist the end to secure it in place.
2. Insert the spool gun control cable into the pin socket.
3. Connect the dinse plug into the positive (+) dinse connection on the front of the machine.
4. Select Spool Gun in the MIG Mode menu on the screen (see "7.3 MIG Mode" on page 58).

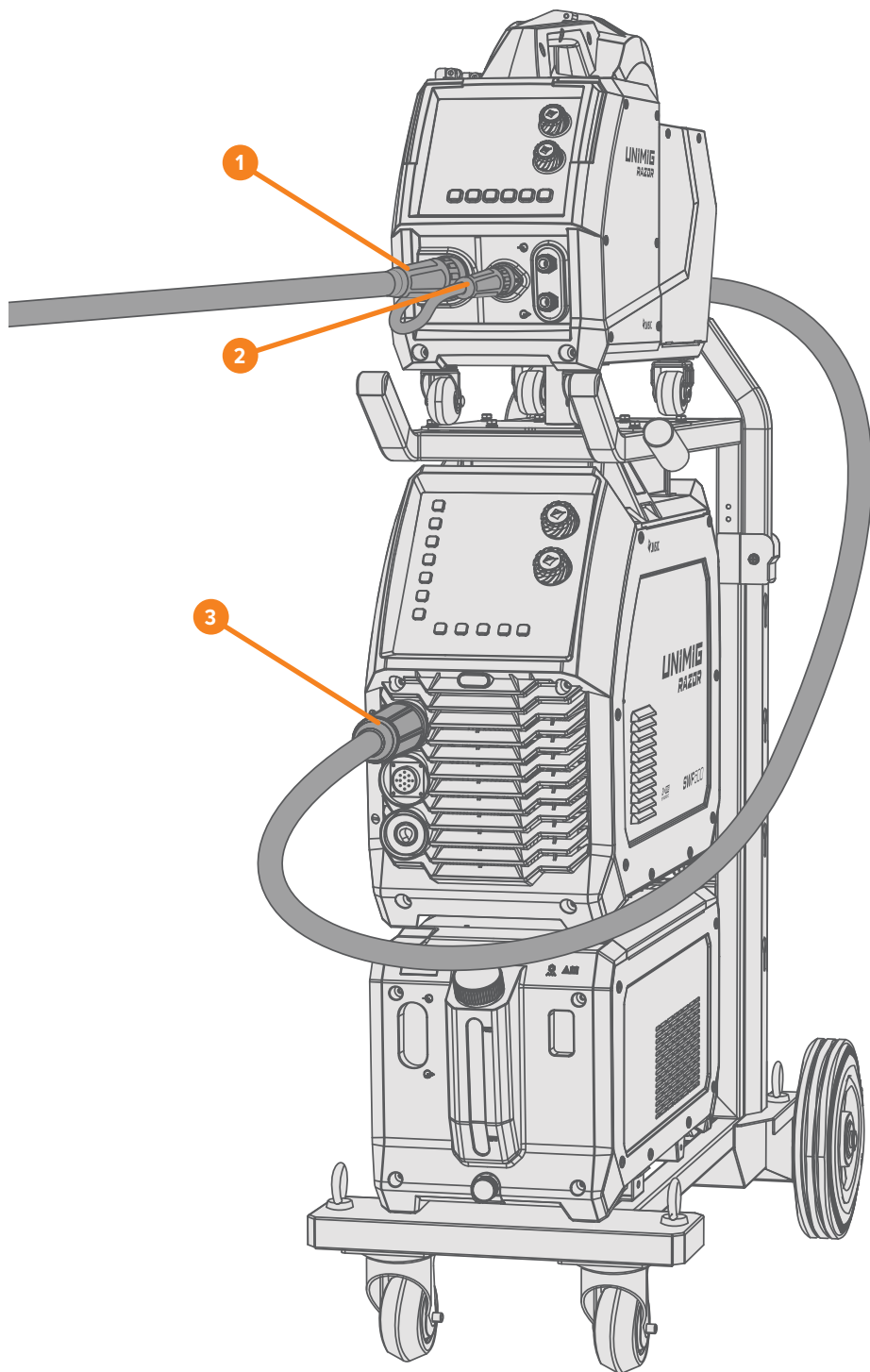

6.4 Connecting a Push-Pull Gun

Air-Cooled

1. Connect the push-pull gun into the Euro connection and twist the end to secure it in place.
2. Insert the push-pull gun control cable into the pin socket.
3. Connect the dinse plug into the positive (+) dinse connection on the front of the machine.
4. Select Push-Pull Gun in the MIG Mode menu on the screen (see "7.3 MIG Mode" on page 58).

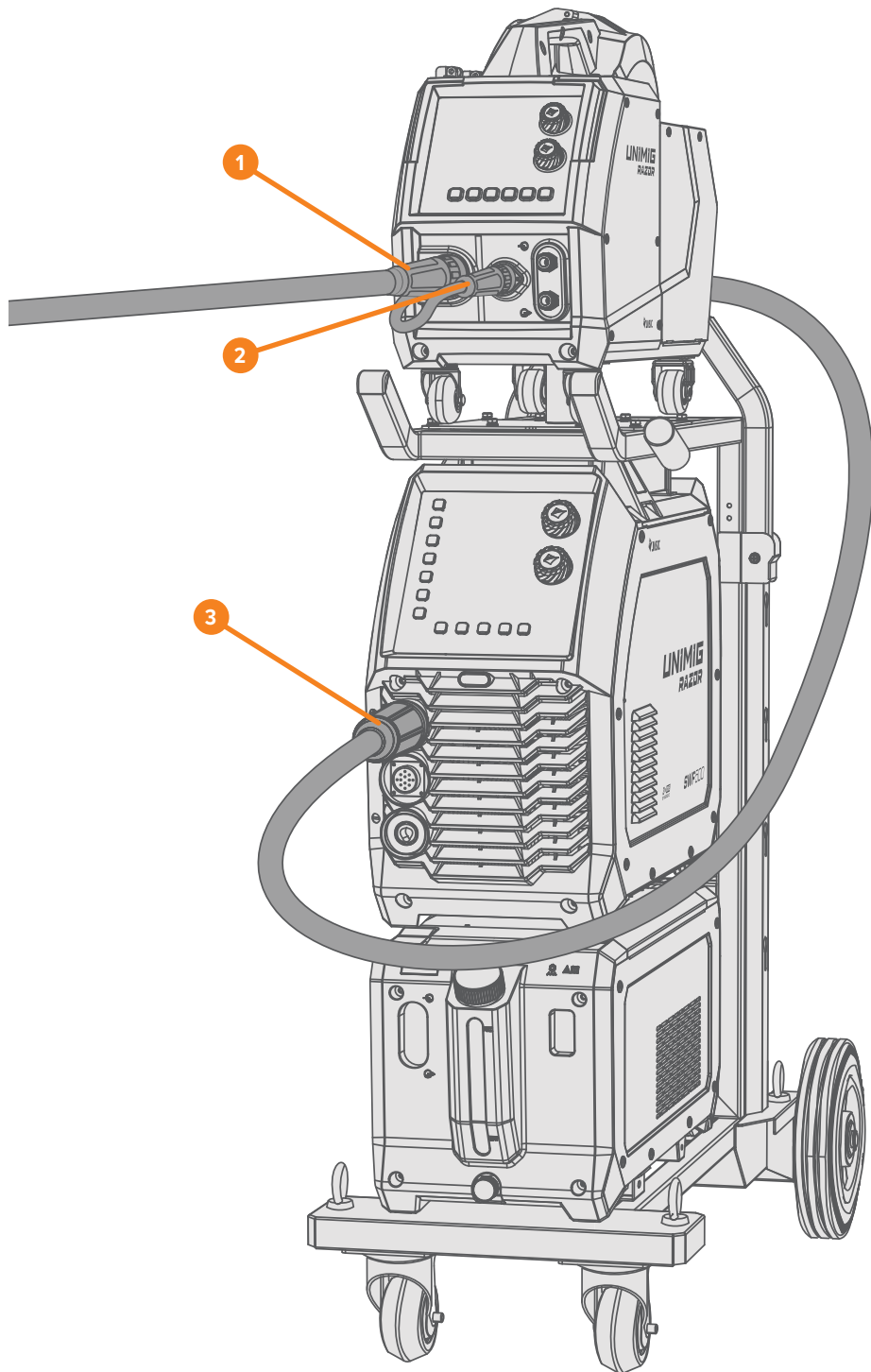

Water-Cooled

1. Connect the push-pull gun into the Euro connection and twist the end to secure it in place.
2. Insert the push-pull gun control cable into the pin socket.
3. Connect the dinse plug into the positive (+) dinse connection on the front of the machine.
4. Select Push-Pull Gun in the MIG Mode menu on the screen (see "7.3 MIG Mode" on page 58).
5. Plug the red coolant return cable into the red output connection and the blue coolant supply cable into the blue input connection on the front of the separate wire feeder unit.

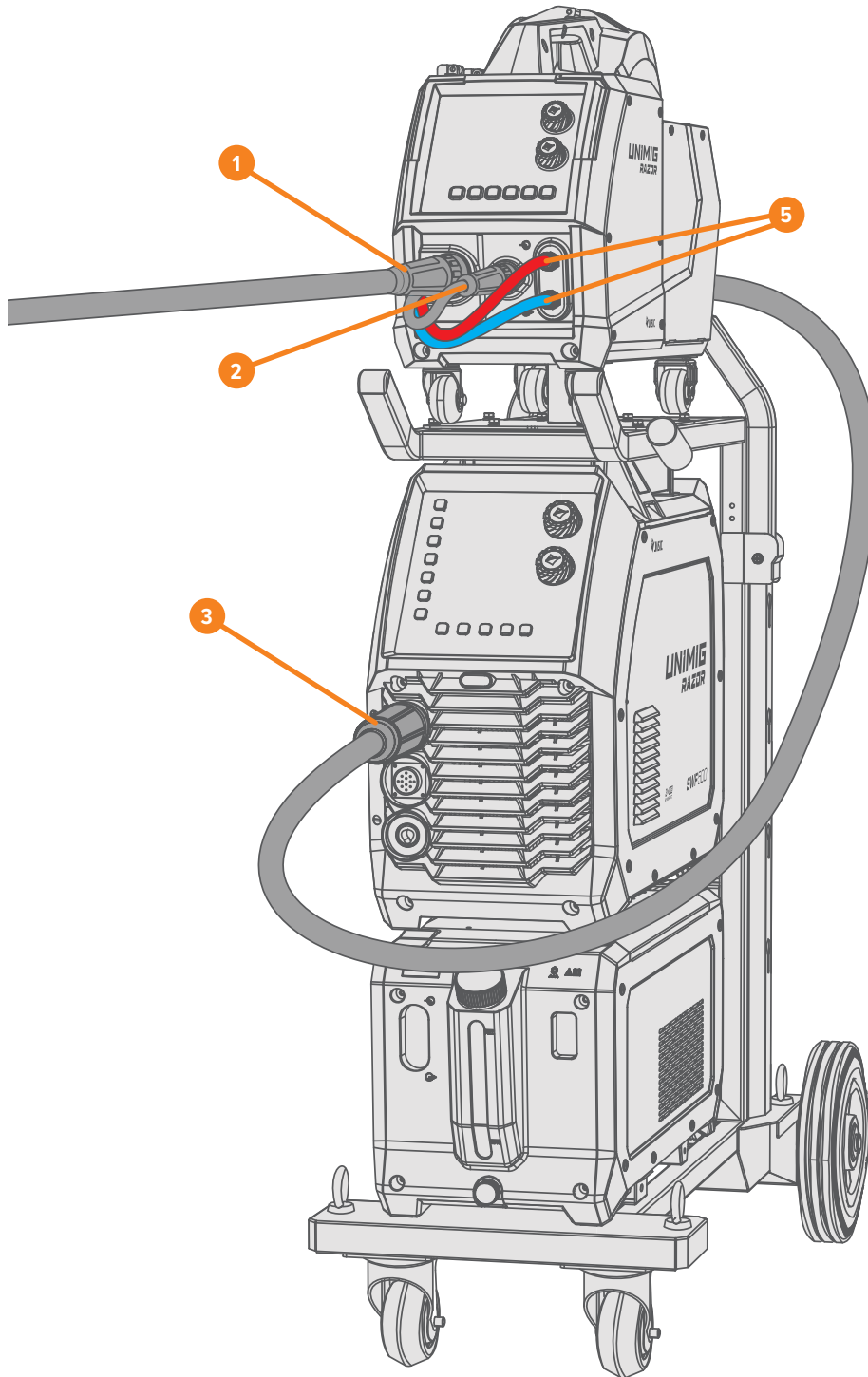

6.5 Connecting the TIG Torch (optional)

1. Connect the TIG torch into the Euro connection and twist the end to secure it in place.

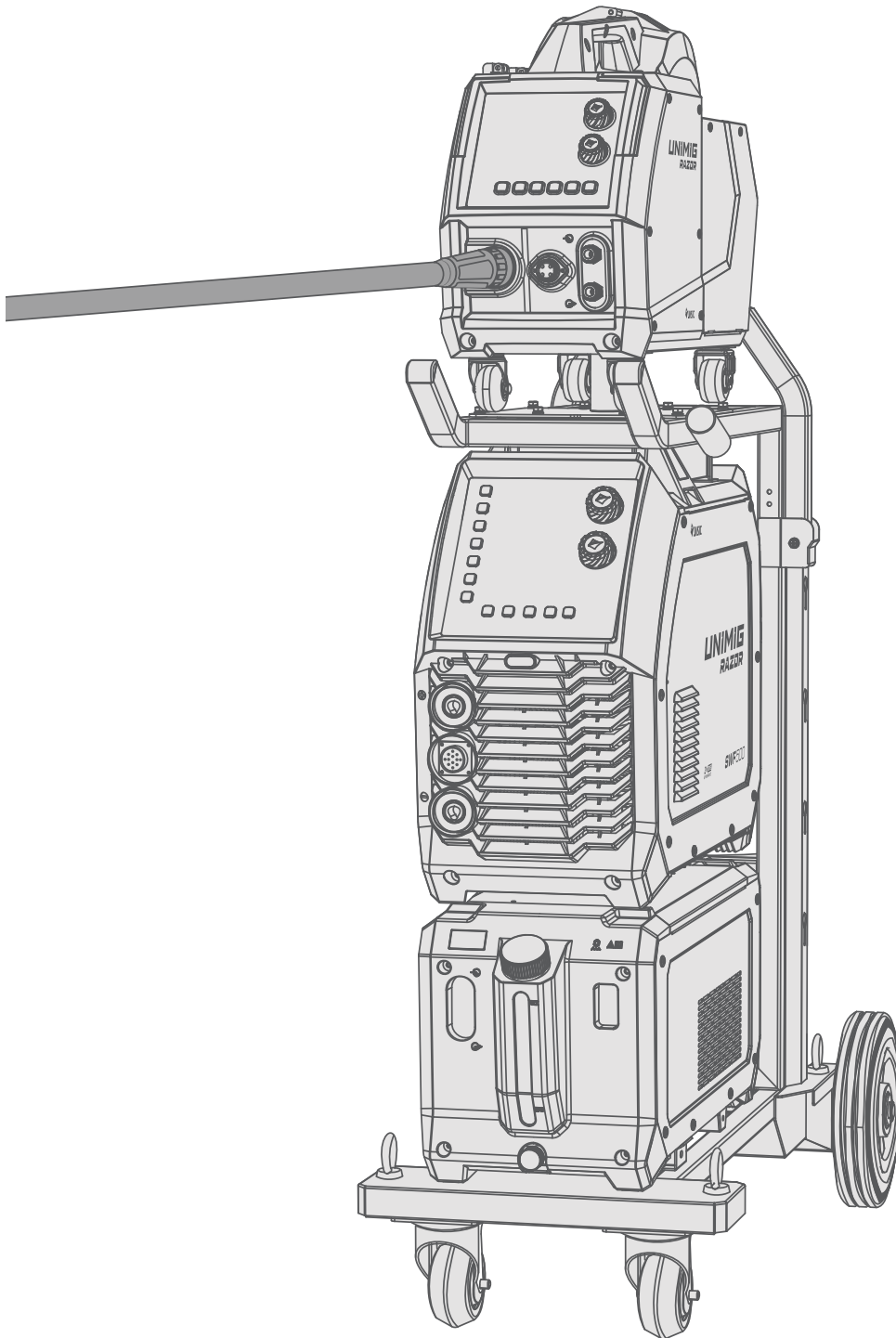

6.6 Connecting the MMA Electrode Holder

DCEN

For DC- electrodes, connect the electrode holder to the negative (-) dinse connection, and twist to lock it in place.

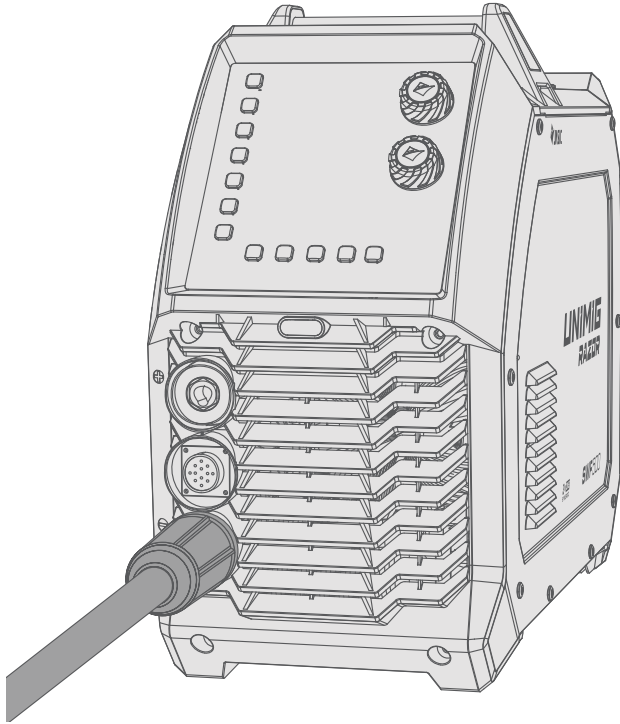

DCEP

For DC+ electrodes, connect the electrode holder to the positive (+) dinse connection, and twist to lock it in place.

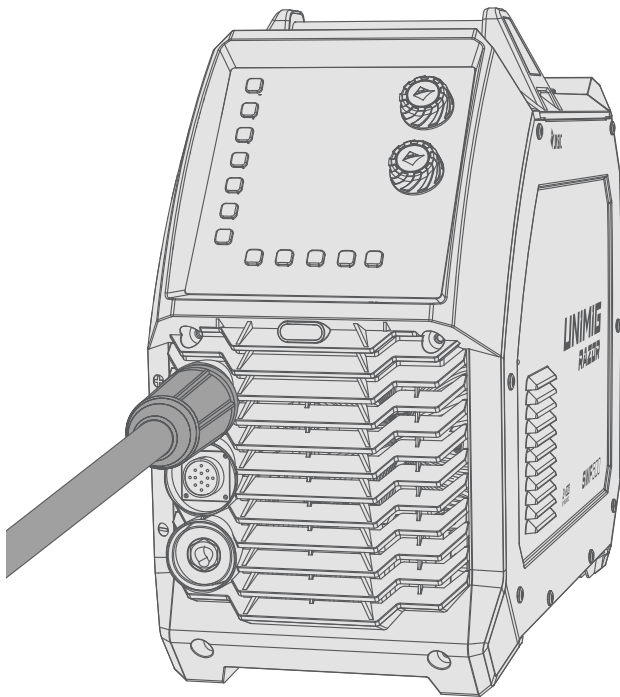

6.7 Connecting the Earth Clamp

Gas-Shielded MIG

For gas-shielded MIG, connect the earth clamp to the negative (-) dinse connection.

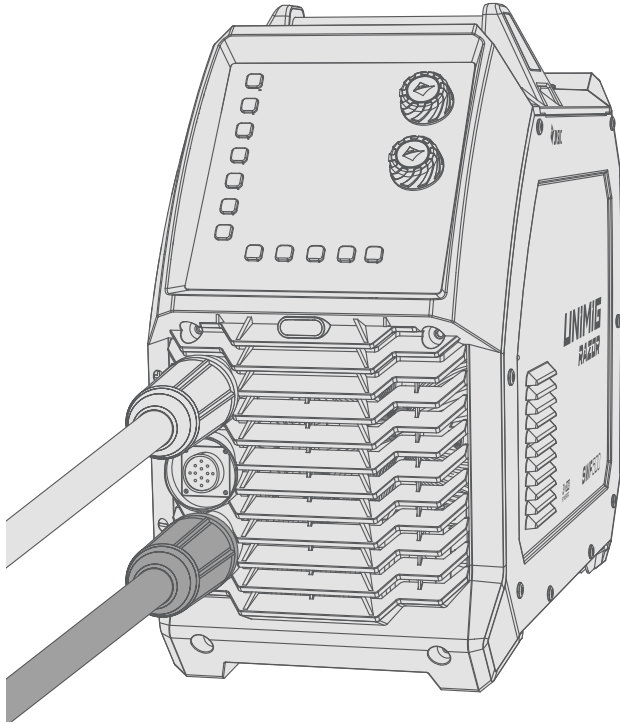

Gasless MIG

For gasless MIG, connect the earth clamp to the positive (+) dinse connection.

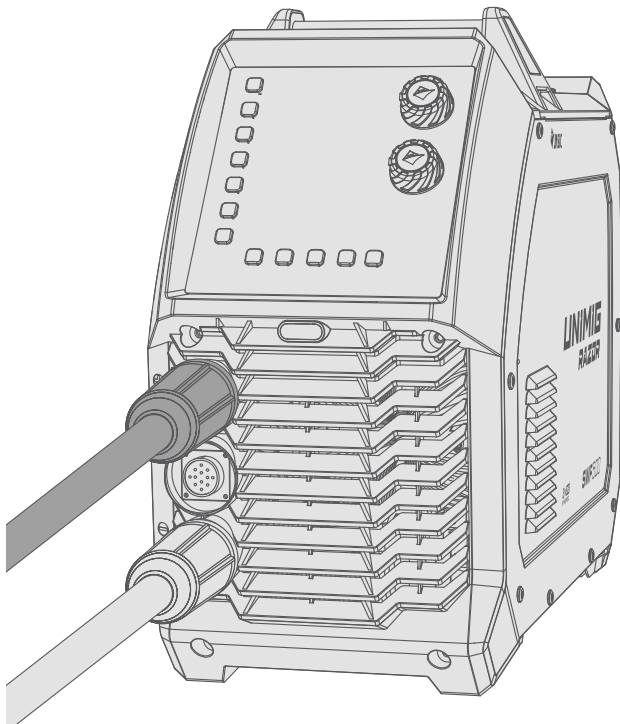

TIG

For TIG, connect the earth clamp to the positive (+) dinse connection.

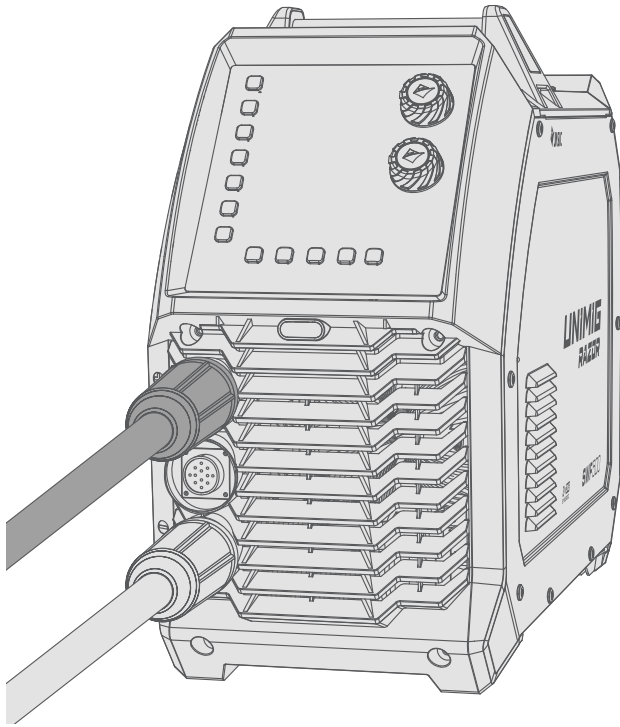

MMA

DCEN

For DC- MMA electrodes, connect the earth clamp to the positive (+) dinse connection, and twist to lock it in place.

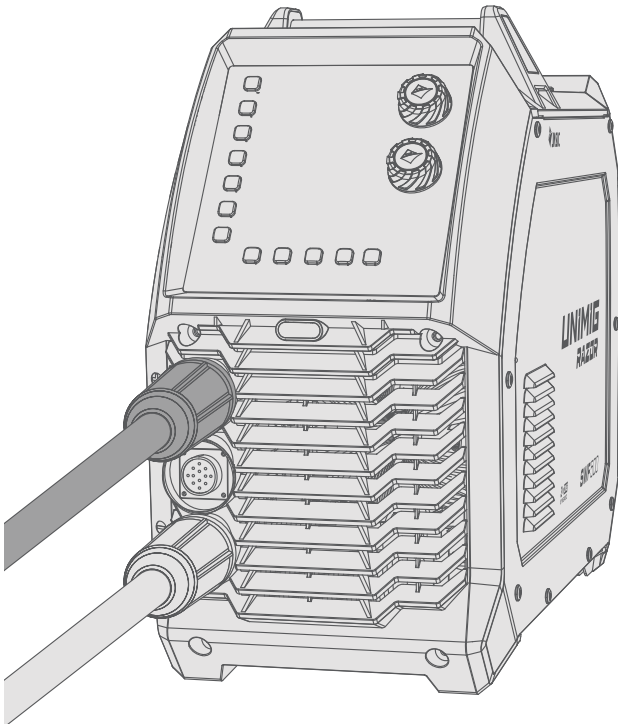

DCEP

For DC+ MMA electrodes, connect the earth clamp to the negative (-) dinse connection, and twist to lock it in place.

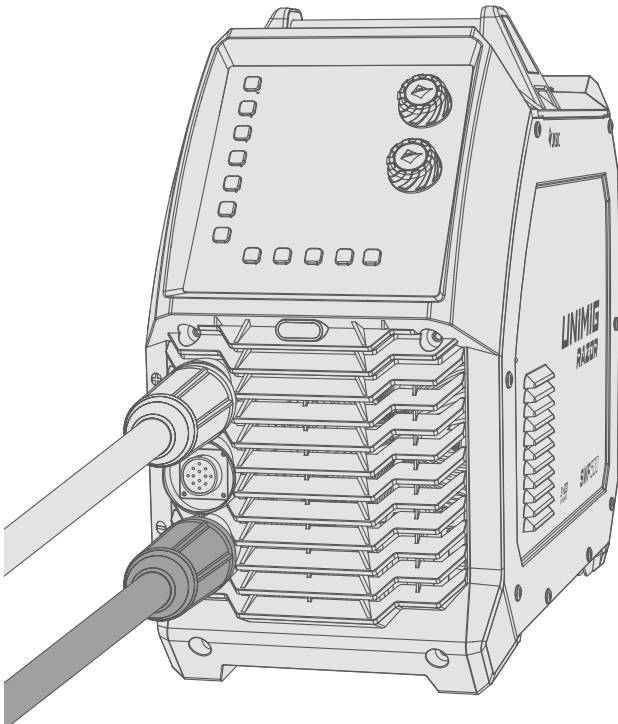

6.8 Installing & Replacing the Drive Rollers

Select the drive roller that suits the wire material and size being used. This machine comes with three types of roller:

- **V groove** - for solid wires like mild and stainless steel
- **F groove (Knurled)** - for flux-cored wires
- **U groove** - for soft wires like aluminium

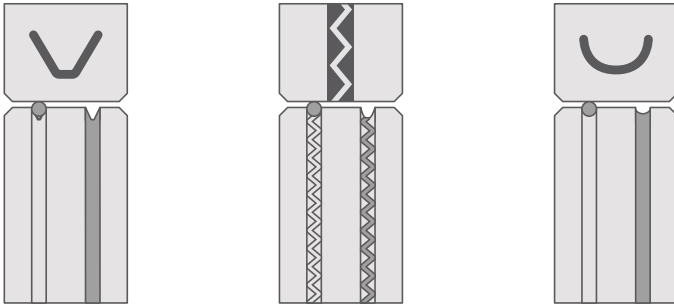

i The wire size label on the drive rollers corresponds with the opposite groove.

When installing the drive rollers, the label on the roller for the desired wire size should be facing outwards.

E.g. If 1.2mm wire is installed, the 1.2mm label on the roller should face outwards when it's inserted, so the 1.2mm wire groove lines up with the wire.

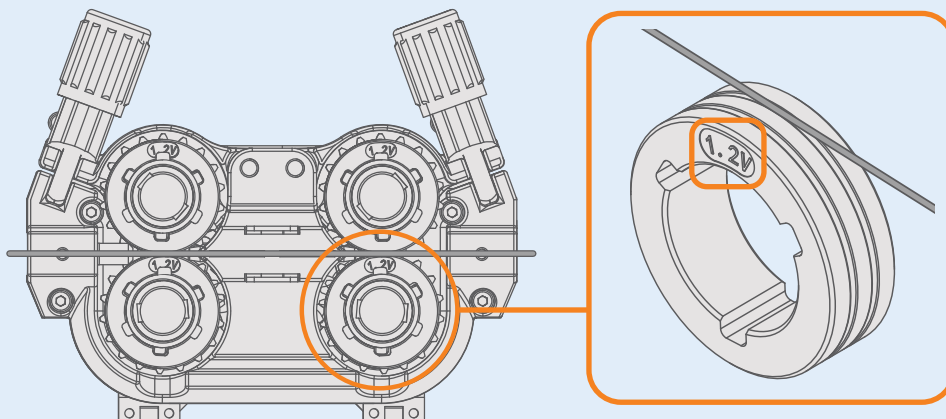

1. Pull down the drive roller tensioner knobs to release the upper wire drive rollers and lift them out of the way.

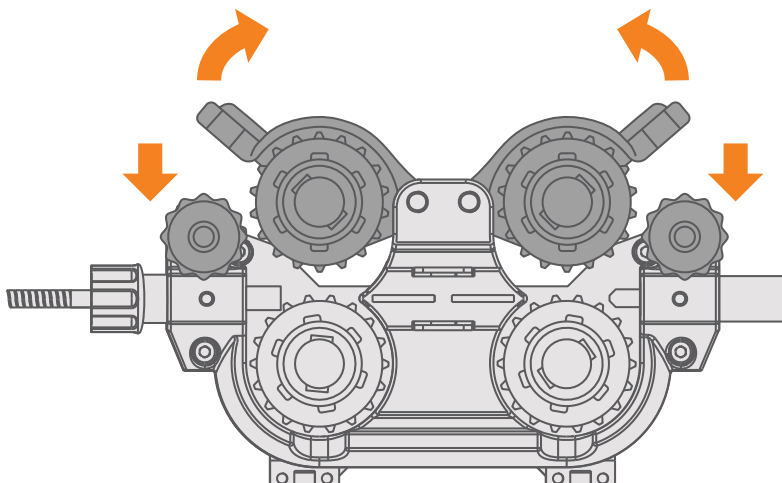

2. Unlock the roller caps.

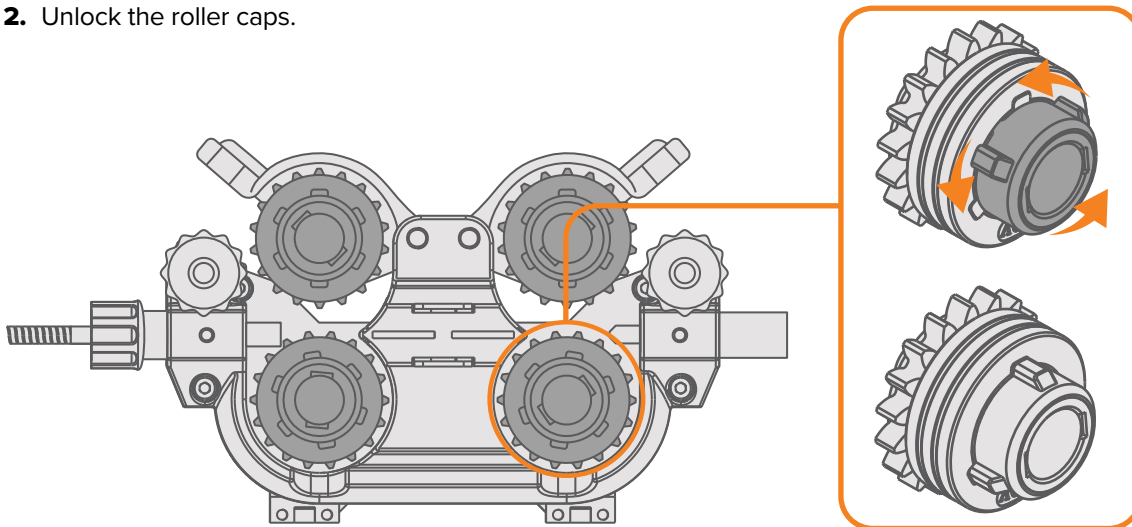

3. Remove the drive rollers and replace them with the necessary rollers. When inserting a new drive roller, make sure to line up the key slot.

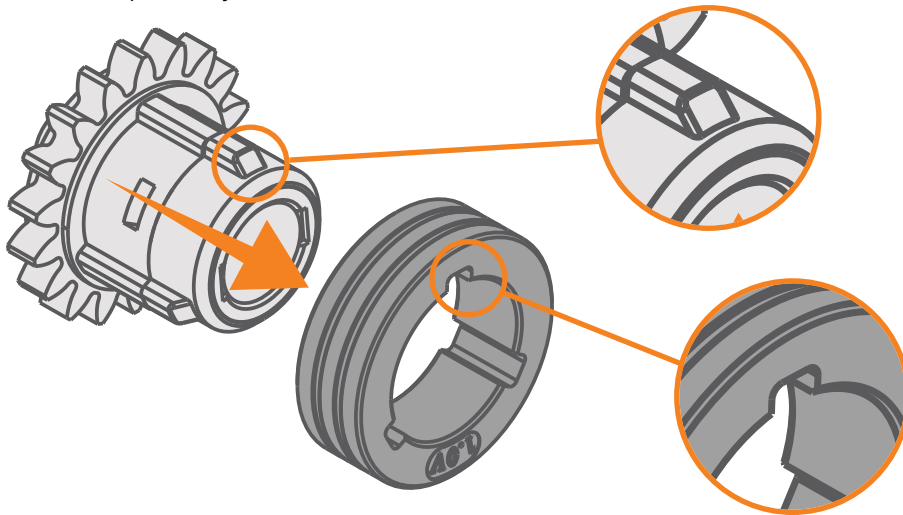

4. Repeat these steps in reverse and screw the roller caps back on, close the upper drive rollers and lift the tensioner knobs back up to lock them into place.
5. See "6.11 Installing & Replacing the Wire" on page 38 for more information on how to install the wire.

6.9 Installing & Removing the Guide Tube

i Before changing the inlet tube, remove the MIG torch and any wire that may be inside the machine.

If there is no guide tube pre-installed in the machine, or you are swapping from aluminium back to a mild or stainless steel wire, a guide tube needs to be installed.

To Install the Guide Tube

1. Insert the guide tube into the Euro Connection block.

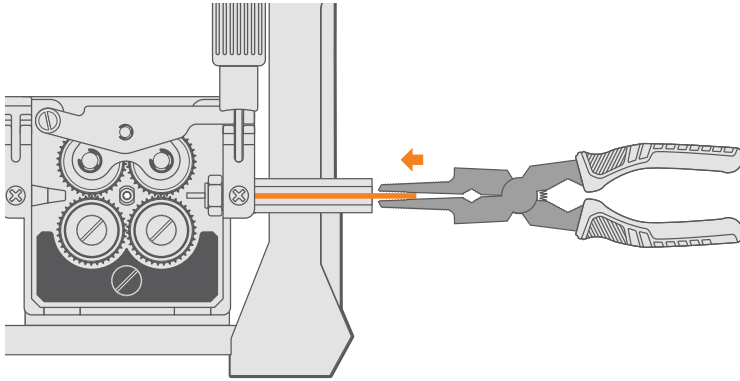

When using soft wires like aluminium, it is recommended to remove the guide tube so that the liner can be fed all the way to the drive rollers. This helps to eliminate potential feeding issues.

To Remove the Guide Tube

1. Use a small screwdriver and leverage it into the gap between the circlip lock and the guide tube to remove the circlip.
2. Remove the guide tube from the Euro Connection block.

If there is no circlip lock on the guide tube, it can be pushed from the drive roller side and out the front of the Euro Connection block.

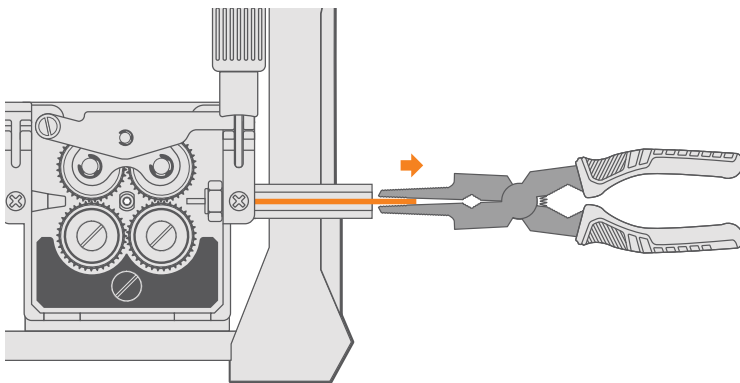

6.10 Installing & Replacing the Wire

Make sure you have the correct drive rollers installed for the wire being used.

i Install the welding torch before installing the wire spool.

i Always check that the drive roller, liner, contact tip and gas nozzle are suitable for the wire being used.

6.10.1 To Install a Wire Spool

1. Open both the Separate Wire Feeder and drive roller compartments to access the spool holder and rollers.
2. With the retaining nut off, slide the wire spool onto the spool holder.
3. Lock it into place by reinstalling the spool retaining nut.

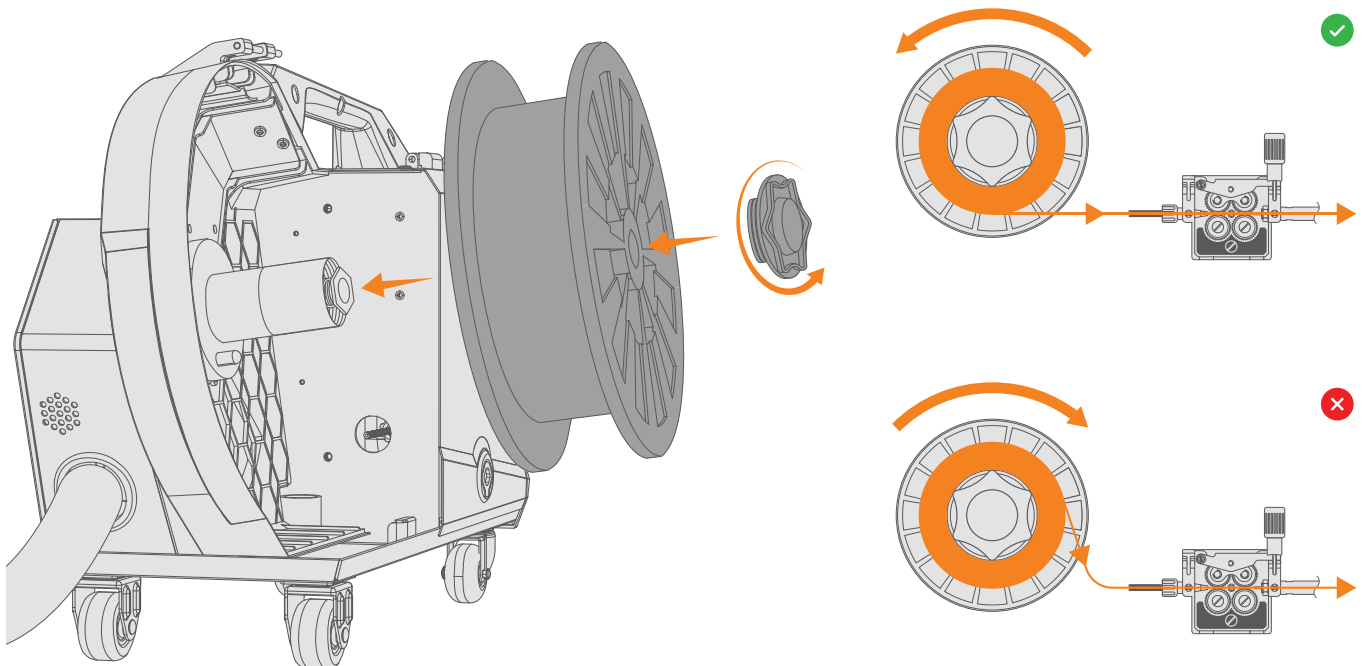

i Ensure the wire spool is facing the right direction with the filler wire able to run from the bottom of the spool to the drive rollers.

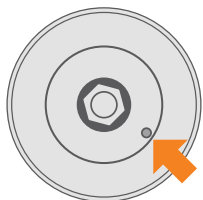

i Ensure you line up the keyhole on the spool with the key on the base of the spool holder.

- Pull down the drive roller tensioner knobs to release the upper wire drive rollers and lift them out of the way.

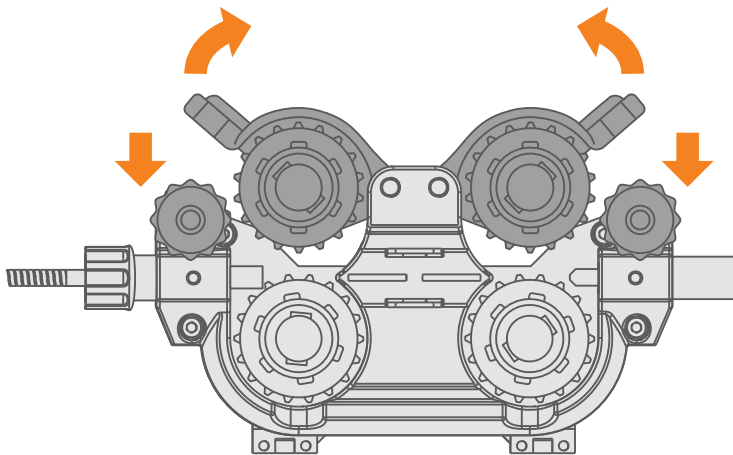

- Release the filler wire end from the spool and cut off any wire that is deformed and file the end smooth.

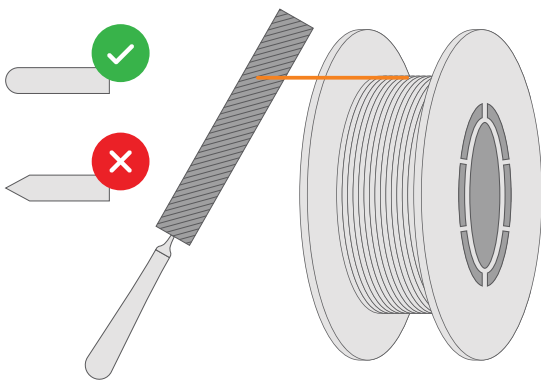

⚠ Sharp edges on the filler wire can cause damage to the torch liner.

- Feed the wire through the inlet guide tube and through to the outlet guide tube. Ensure that the wire passes through the roller's grooves.

ℹ The inlet guide tube runs between the spool holder compartment and the drive roller compartment.

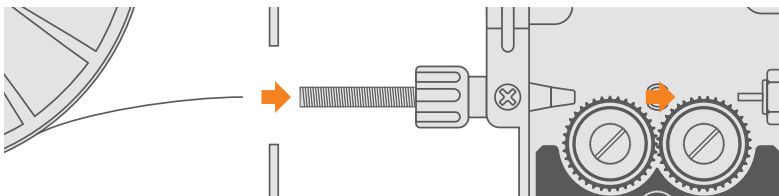

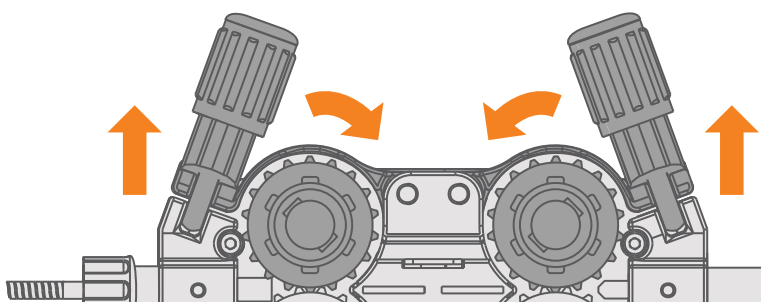

- Close the upper drive rollers and lift the tensioner knobs back up to lock the wire into place.

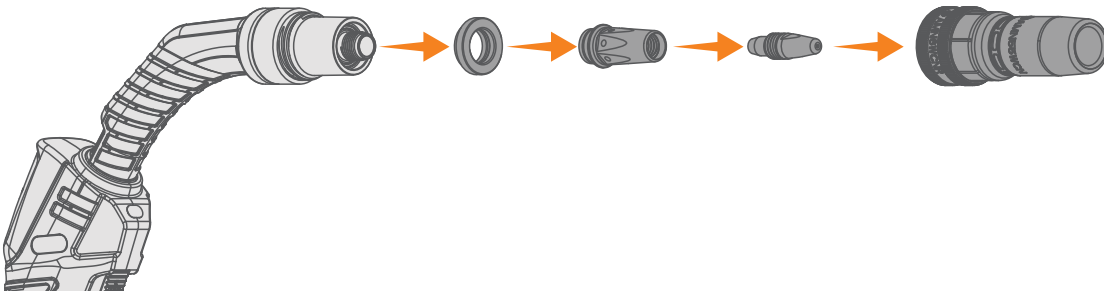

8. Prepare your MIG torch for having wire fed through it by removing the front-end consumables.



9. Feed the wire through the torch. To do this, hold the Wire Inch button  on the front panel of the power source or the Wire Inch button  inside the SWF. Once the wire is fed through the torch, you can replace the torch consumables.

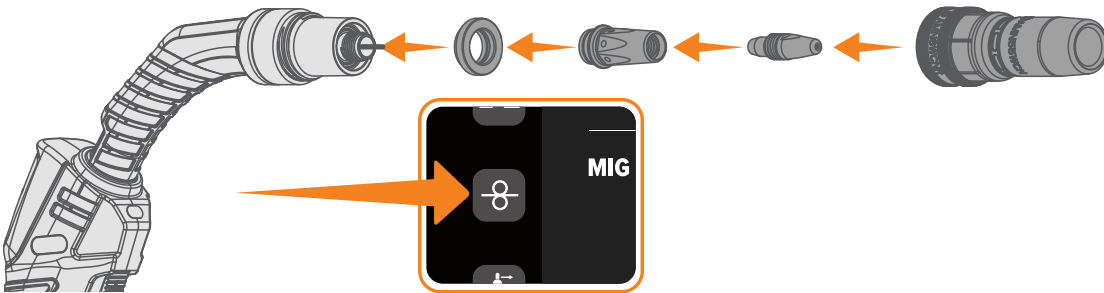

10. Adjust the tension on your drive rollers and wire with the tensioner knobs.

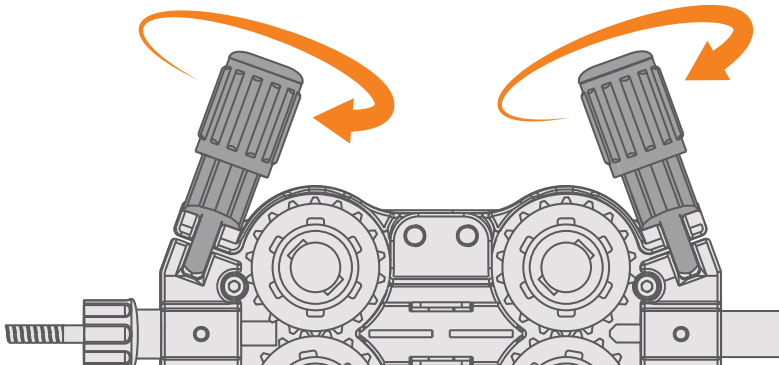

⚠ Excessive tension will deform the filler wire and can damage cored or coated wires.

To manually tension your drive rollers:

- Start with a cold torch and feed the wire until about 50mm (5cm) hangs out of the end of the torch tip.
- Decrease the tensioner arms by rotating anticlockwise so that the wire slips (the rollers are spinning, but the wire doesn't move) when the trigger is pulled.
- Once the tension has been removed, turn the tension level a half-turn clockwise to increase the tension, gripping the exposed wire between thumb and forefinger with light pressure.

i Don't grip the wire too hard. The pressure should be firm but not excessive.

- Pull the trigger while holding the wire. If it slips, repeat the process.
- Keep adding tension until you can't stop the wire with your fingers, and it feeds smoothly without slipping.

⚠ Keep fingers and hands clear of the wire as it feeds from the torch. Pinch the wire from the sides, so nothing is blocking its path as it exits the torch.

6.10.2 Adjusting the Spool Hub Brake

To adjust the spool hub brake, turn the spool nut to control the brake.

1. Turn the spool nut clockwise to increase the brake
2. Turn the spool nut anticlockwise to decrease it.

The spool nut can be accessed when the retaining nut is removed from the spool holder.

The brake is properly adjusted when the spool stops within 10mm to 20mm (measured at the outer edge of the spool) after the MIG torch trigger is released. The wire should be slack without coming off the spool.

⚠ Too much tension on the brake can cause rapid wear of the drive roller motor, overheating of the electrical components and could increase the chances of the filler wire burning back into the contact tip.

6.10.3 To Remove the Wire Spool

1. Unscrew and remove the spool retaining nut.

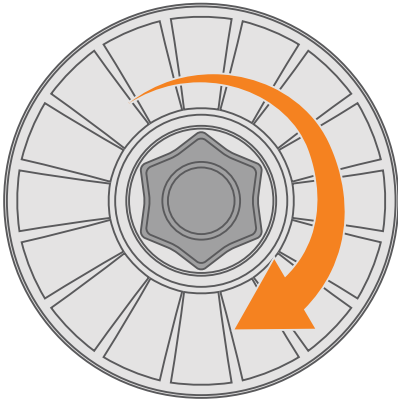

2. Cut the wire behind the inlet guide and hold the end while removing the wire spool from the machine.

⚠ Letting go of the loose wire before reattaching it will cause it to unspool and lose its precision winding, rendering it unusable.

3. Remove the filler wire from inside the welding torch and drive rollers.

6.10.4 To Install a Wire Spool in the Spool Gun

1. Unscrew the spool holder and remove the spool housing cover.

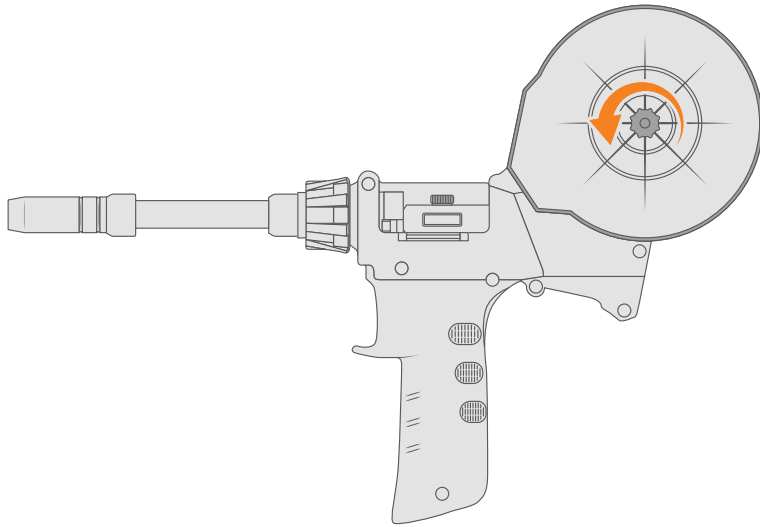

2. Push back the spool guides, and place the wire spool onto the spool nut.

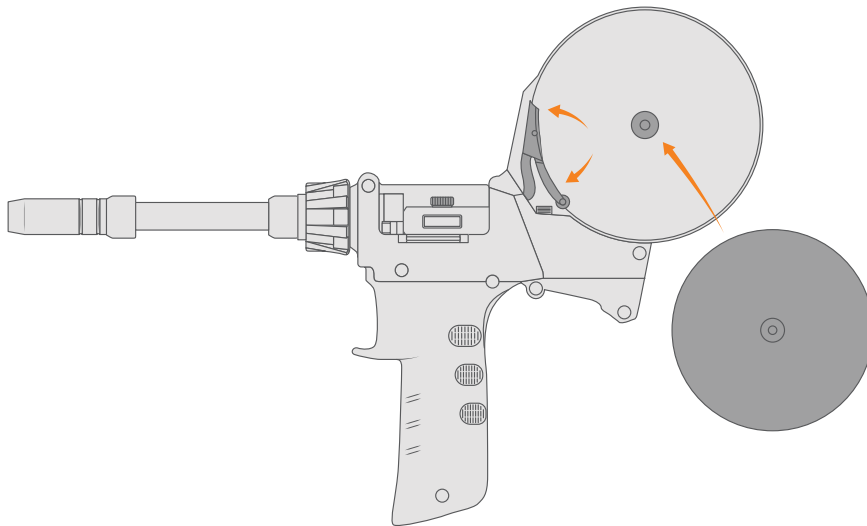

3. Feed the wire through the inlet guide tube.

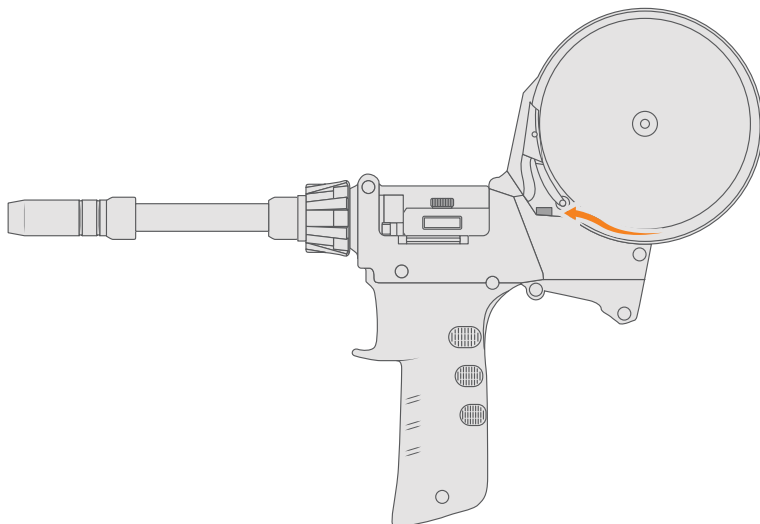

4. Open the drive roller cover, and loosen the roller tension knob.

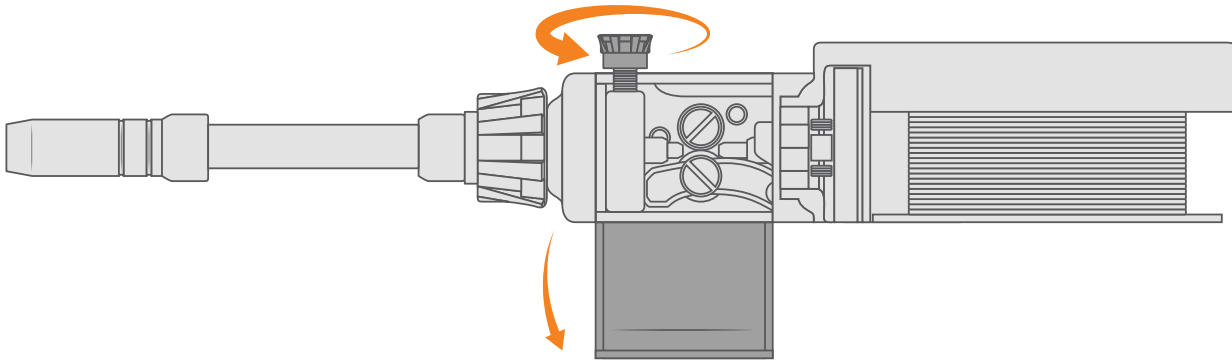

5. Lift the roller lock up and open the wire drive.

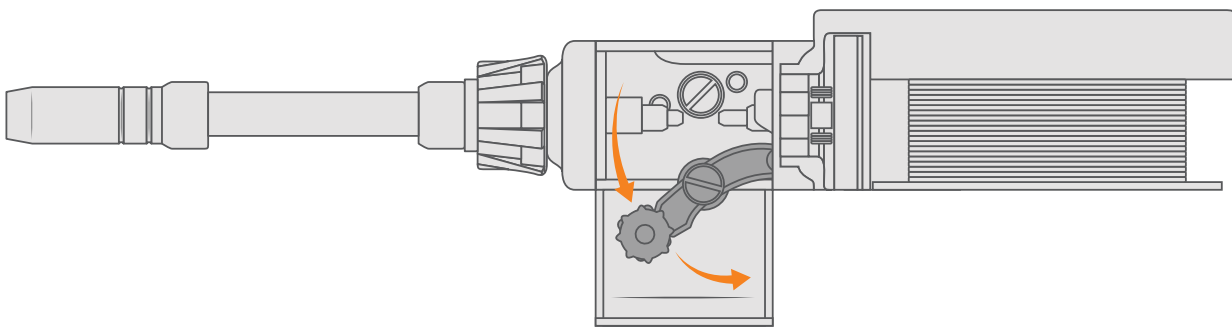

i Ensure you have the correct drive roller for the wire size you are using. If not, replace it with the correct size.

6. Feed the wire through the drive roller and through the outlet guide tube.

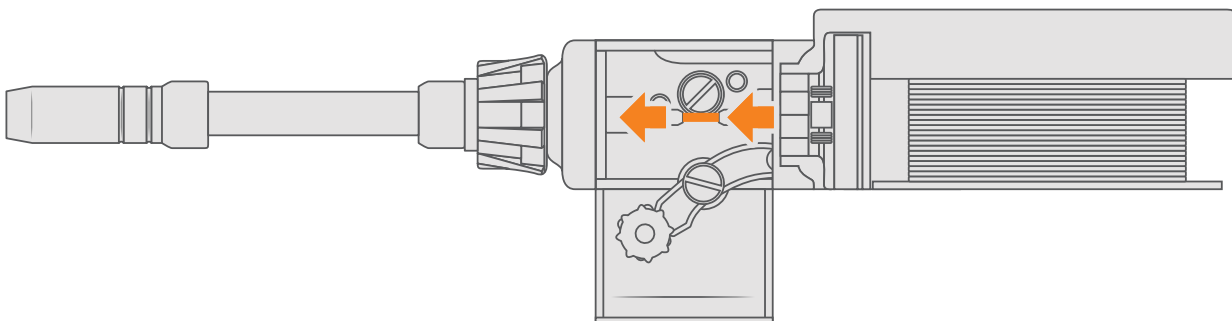

7. Close the wire drive and tighten the roller tension knob.

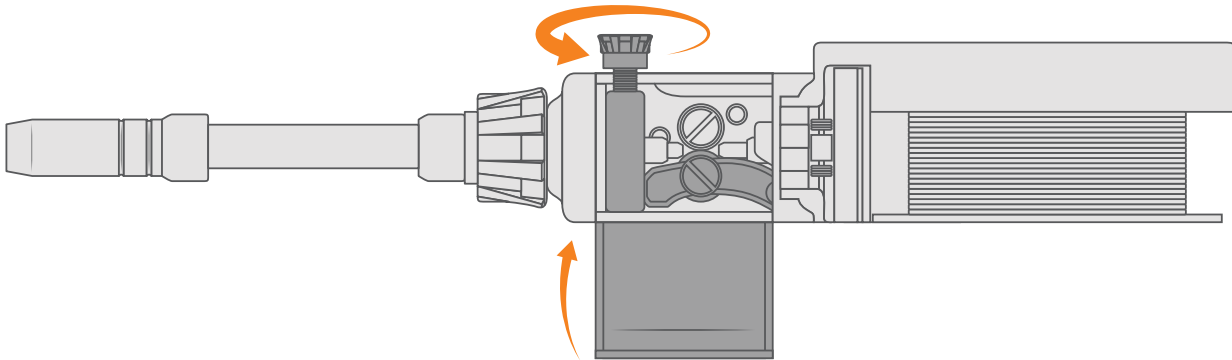

8. Remove the front-end consumables in preparation for feeding the wire.

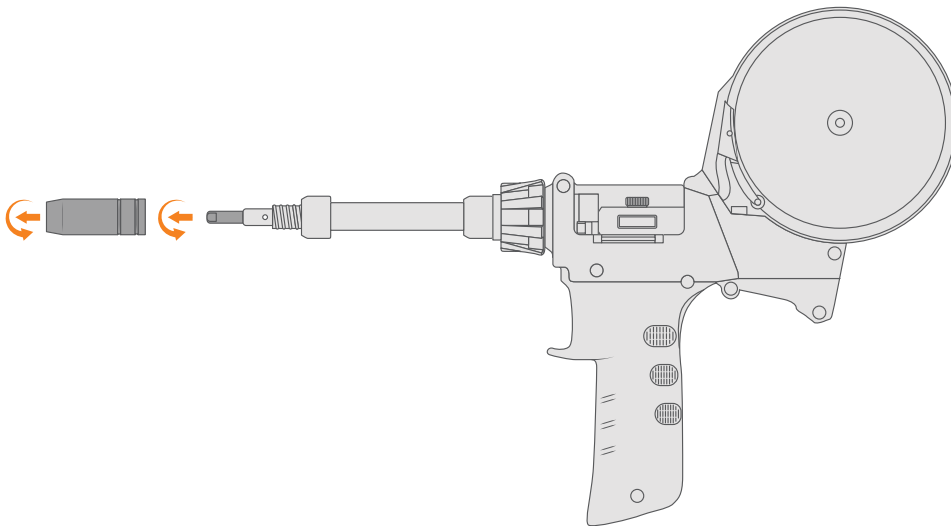

9. Press the torch trigger to feed the wire out of the torch nozzle.

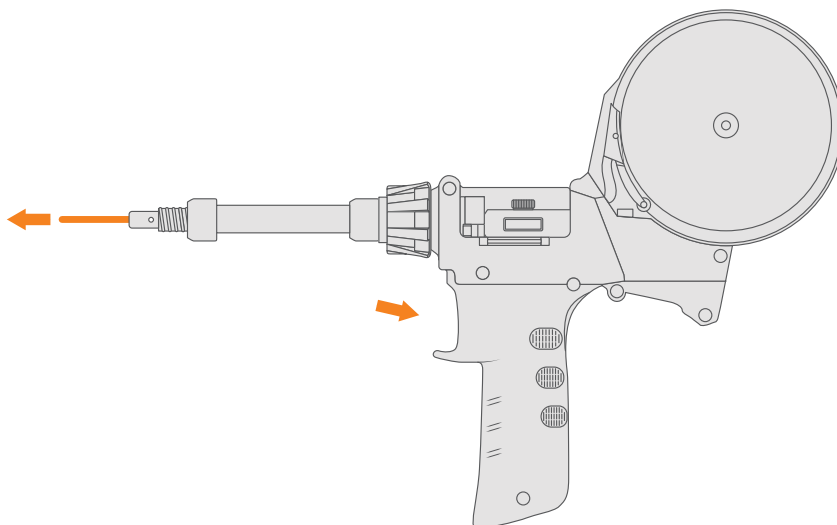

10. Replace the front-end consumables.

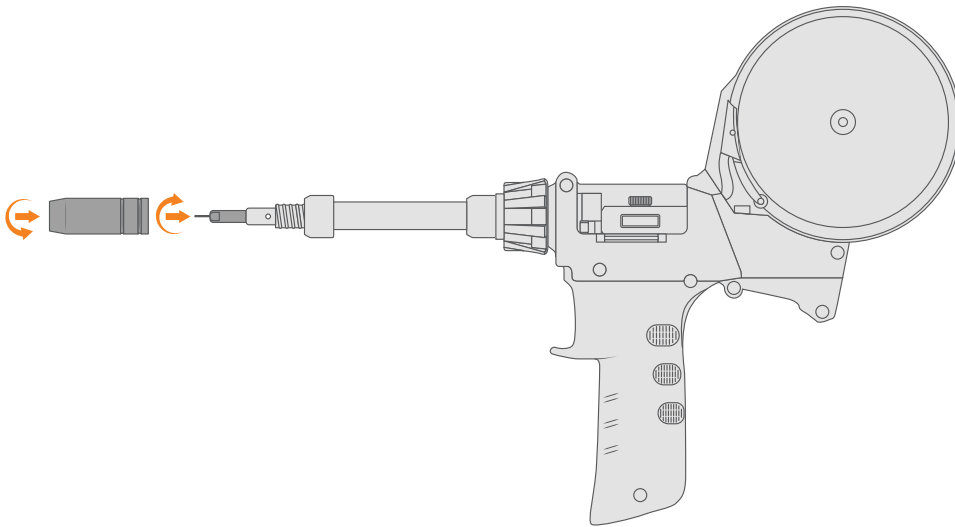

11. Replace the spool housing cover and tighten it.

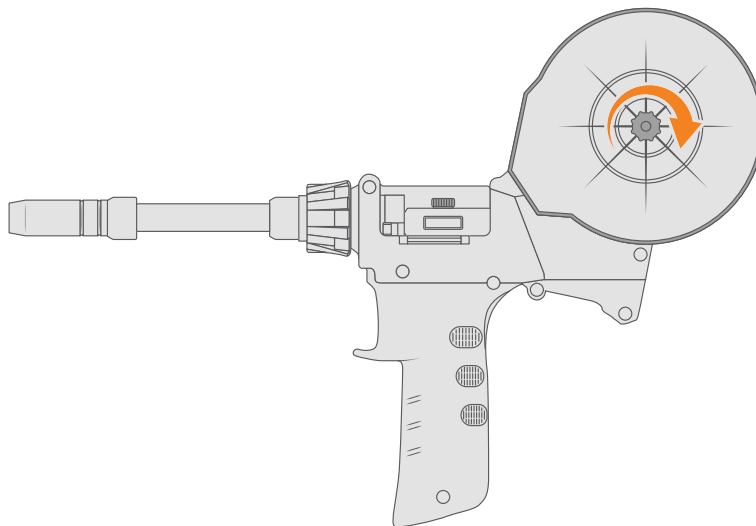

6.11 Installing & Replacing the Torch Liner

i UNIMIG MIG torches are delivered with a torch liner preinstalled.

The torch liner is a consumable part which will need to be replaced when it becomes worn or damaged, or if the filler wire material and/or diameter changes. The previous filler wire will need to be removed before the liner can be replaced.

i If the filler wire material or diameter is changed, ensure the correct driver rollers are installed to suit.

6.11.1 Steel Liner

1. Remove the nozzle, contact tip, tip holder and insulator from the front end of the torch.

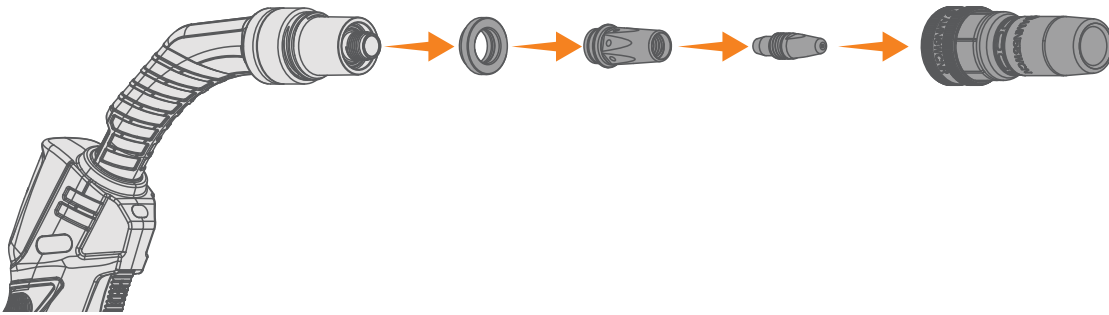

2. Remove the liner retaining nut from the end of the torch.

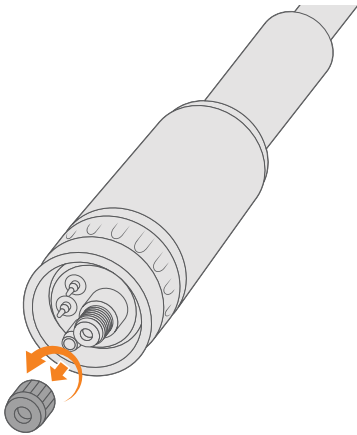

3. Remove the existing liner. Make sure the MIG torch is laid out straight when you do this.

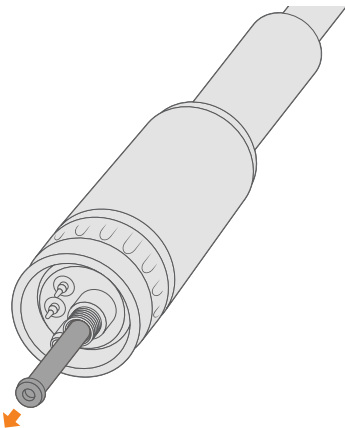

4. Install the new liner down the torch lead to the end of the torch neck.

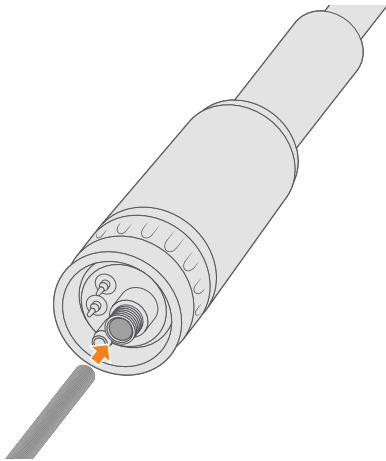

5. Fit the liner retaining nut and screw it halfway down. Don't tighten it yet.

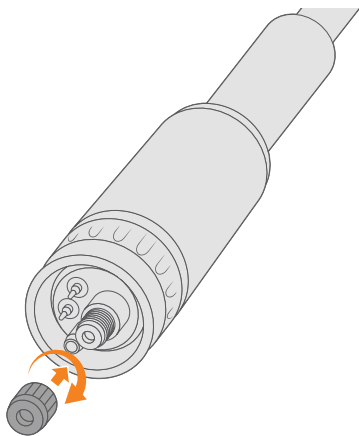

6. Cut the excess liner off so it's just below flush with the torch neck. The liner should line up with the bottom of where the tip holder screws in.

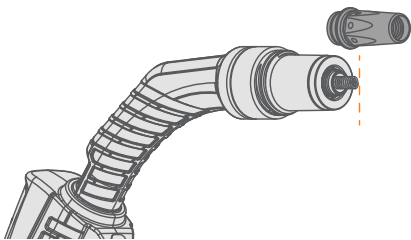

i Remove any sharp edges that could potentially damage the filler wire.

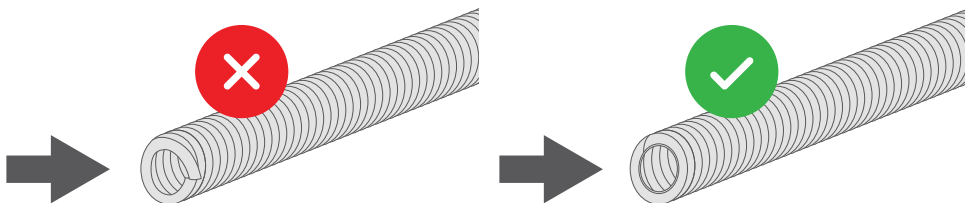

⚠ Don't cut the liner too short, leaving a gap between the liner and tip holder inside the torch can cause wire feeding issues.

7. Replace the front-end consumables on the torch. If you can't screw the tip holder back into place, the liner is too long and needs to be trimmed.

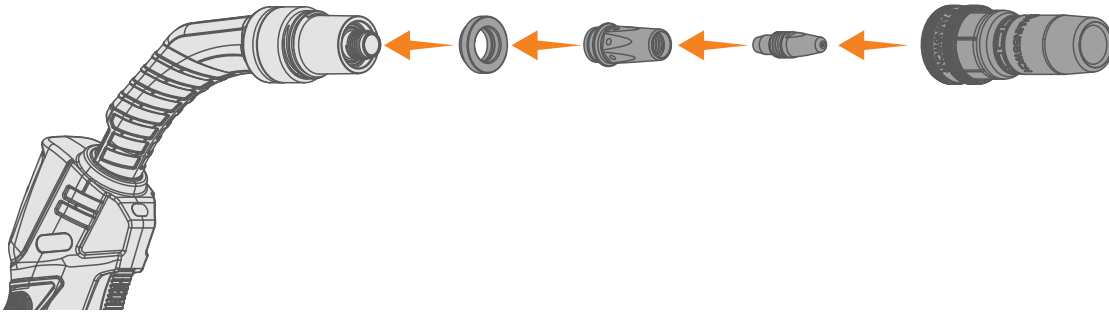

8. Fully screw down the liner retaining nut.

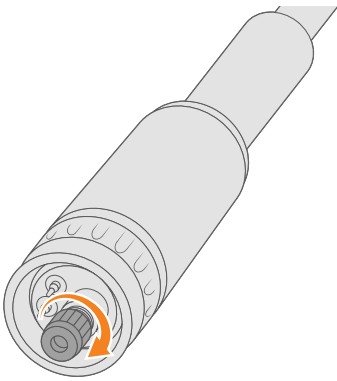

6.11.2 Aluminium Liner

1. Remove the nozzle, contact tip, tip holder and tip holder insulator from the front end of the torch.

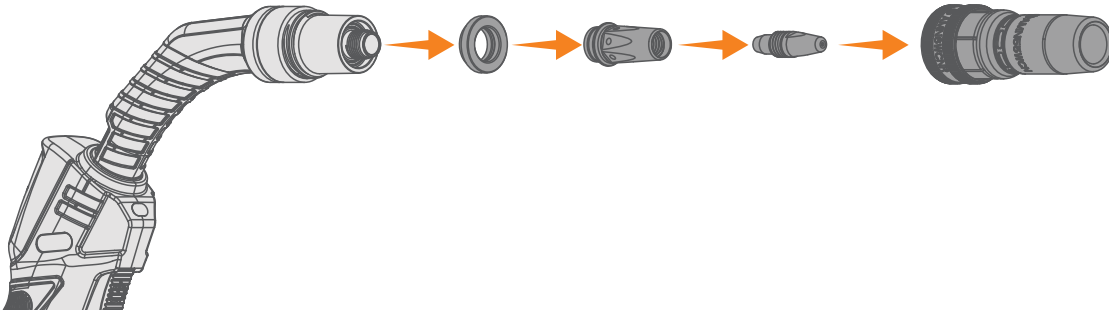

2. Remove the liner retaining nut from the end of the torch.

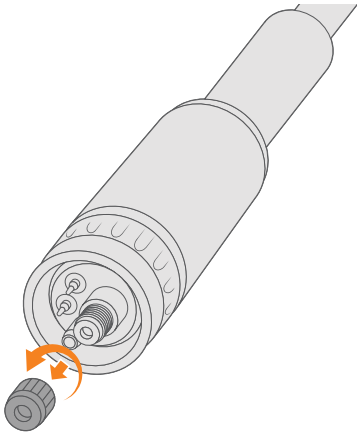

3. Remove the existing liner. Make sure the MIG torch is laid out straight when you do this.

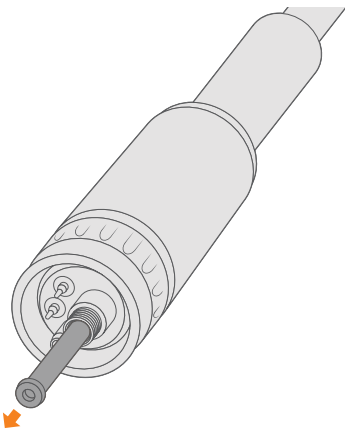

4. Screw the neckspring onto the end of the liner.

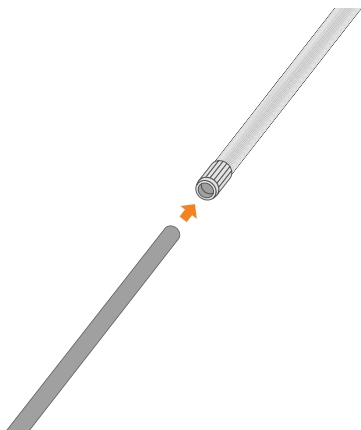

5. Install the new liner down the torch lead to the end of the torch neck until it butts up against the tip holder internally.

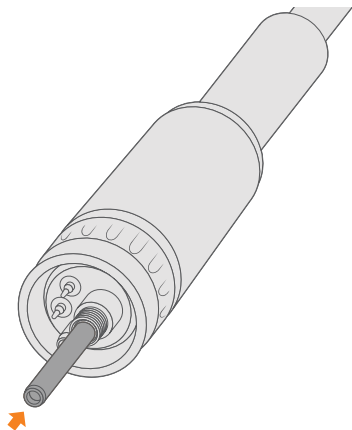

6. Place the collet and o-ring (from inside the retaining nut) onto the end of the liner to crimp it in place, and then lock it into place with the retaining nut.

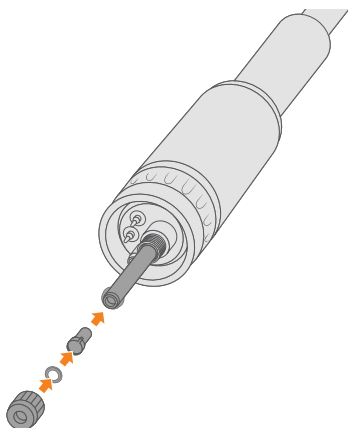

7. Cut the excess liner off so that the liner goes through the Euro connection and sits just before the drive rollers.

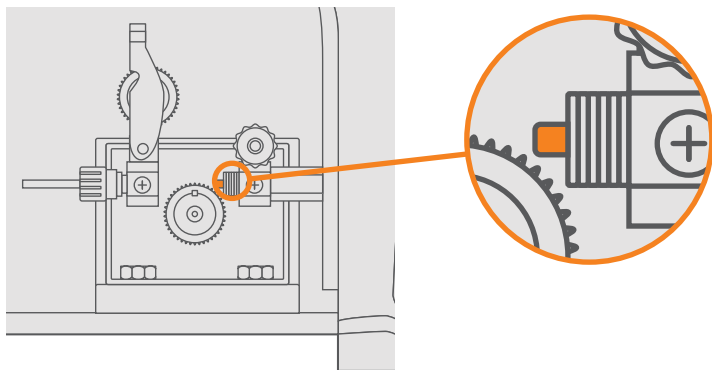

i The liner should be as close to the drive roller as possible without touching it.

8. Replace the front-end consumables on the torch.

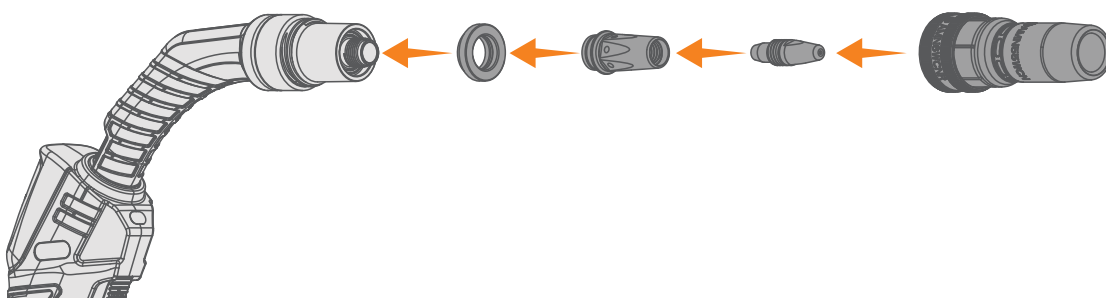

6.12 Installing the Gas Bottle & Testing the Gas Flow

⚠ Handle the gas bottle with care. There is a risk of injury if the gas bottle or the bottle valve is damaged.

ⓘ If you have a new gas bottle, remove the insert tab from the valve.

1. Securely fasten the gas cylinder to a wall or stationary support so it can't fall.
2. Stand to the side and open the gas bottle valve or safety lock quickly to blow away any dirt or dust from it before closing it again.
3. Screw in your regulator or flowmeter so that the face of the gauge is vertical, and then tighten it with a wrench.
4. Connect the gas hose to the regulator/flowmeter outlet connection and the gas fitting on the back of the machine.
5. Open the gas bottle valve or safety lock and adjust your flow rate using the gas flow regulation screw.

ⓘ When turning the gas flow regulation screw, do it slowly. Cranking the screw can damage the regulator/flowmeter and cause gas leakage.

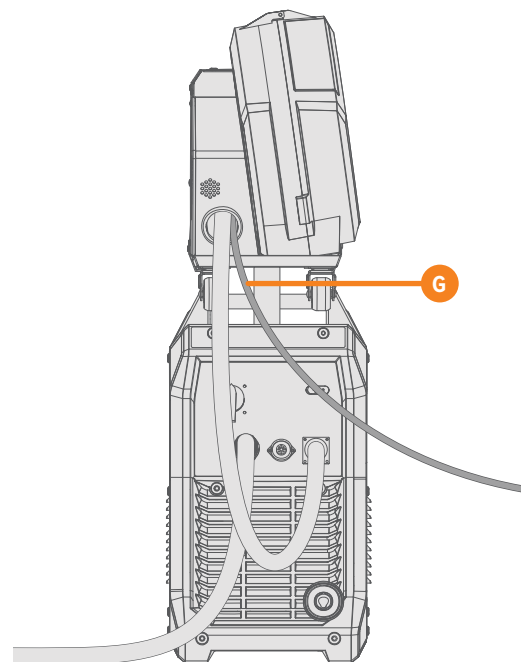
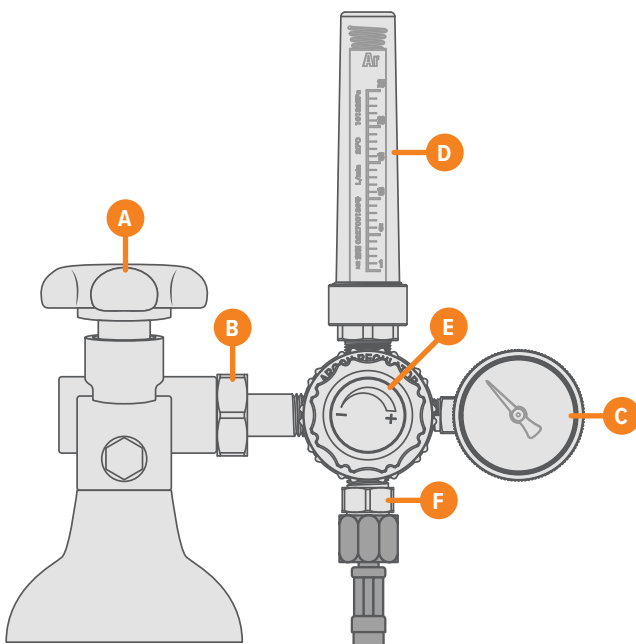

- A.** Gas bottle valve
- B.** Inlet connection (AS2473 Type 10)
- C.** Gas bottle contents indicator
- D.** Gas flow meter
- E.** Gas flow regulation screw
- F.** Outlet connection (5/8" UNF Male RH)
- G.** SWF gas hose

Recommended Gas Flow Rates

Gas Mixture	TIG	MIG
Argon	5-15L/min	10-25L/min
Helium	5-15L/min	
Argon + 18-25% CO ₂		10-25L/min
CO ₂		10-25L/min

The gas flow rates mentioned are intended as guidelines only. Actual gas flow rates may vary based on the specific gas cup selected.

6.12.1 Testing the Gas Flow

i Testing the gas flow via an external gas test is recommended as the gas solenoid in the machine can cause a small loss of gas as it travels through the machine internals. A gas test lets you check the difference in the flow rate selected on the regulator/flowmeter and the flow exiting the torch.

1. Open the gas bottle valve.
2. Connect a gas flow tester to the end of the torch and start the gas flow by pressing the gas purge button.
3. Check the gas flow tester is reading the gas flow rate selected.

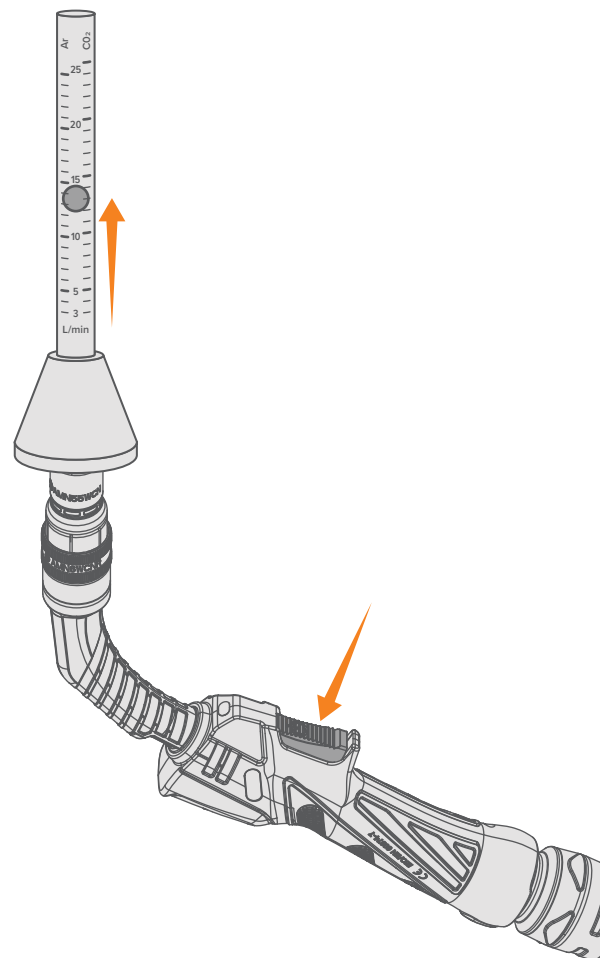

6.13 Regulator Safety & Operation

⚠ This equipment is designed for use with welding grade (inert) shielding gases only.

This regulator/flowmeter is designed to reduce and control the flow of high-pressure gas from a cylinder down to a level that is suitable for the equipment it's supplying. Make sure the pressure regulator is designed for use with high pressure gas cylinders and that the connection nut thread matches the cylinder valve outlet.

Misuse of the equipment can lead to dangerous situations, which could result in accidents. It is crucial for users to avoid such scenarios. Prior to operating or handling the equipment, it is imperative to understand and adhere to the safety guidelines provided in this manual.

The following instructions detail specific practices for using regulators/flowmeters:

1. Do not expose the regulator/flowmeter to inlet pressures exceeding its maximum specified limit.
2. Do not pressurise a regulator/flowmeter if it exhibits any signs of damage, loose components, or appears to be in poor condition.
3. Do not attempt to loosen or detach any parts from the regulator/flowmeter without first ensuring the gas pressure has been fully released. Pressurised gas can forcefully eject a dislodged part, creating a hazard.
4. Do not open the cylinder unless a pressure regulator/flowmeter has been fitted.
5. An opened valve should never be fully opened until resistance is encountered, but should be turned back at least half a turn to prevent the valve from becoming stuck in the open position. This can occur if the valve is left open for long periods of time.
6. Ensure the cylinder valve is fully closed and any gas within the regulator/flowmeter's high and low-pressure chambers has been vented before removing the device from a cylinder.
7. Do not use the regulator/flowmeter as a shut-off valve. To prevent gas flow when downstream equipment is not in use for an extended period, turn off the gas at the source and vent it from the system.
8. Open the cylinder valve slowly and make sure to close it after finishing. When you shut the valve, turn it just enough to stop the gas completely. Do not over tighten.
9. Do not attempt to repair or modify the regulator.

User Responsibilities

This equipment will perform safely and reliably only if it is installed, operated, maintained, and repaired strictly according to the provided instructions. Regular checks are essential to ensure its ongoing safe and reliable operation.

Any necessary repairs, replacements, or adjustments must be carried out promptly. Do not use equipment that is defective. Immediate replacement is required for parts that are broken, missing, visibly worn, deformed, or contaminated.

Typically, the user will bear exclusive responsibility for any malfunctions resulting from improper usage, inadequate maintenance, or repairs conducted by individuals other than certified repair technicians.

Installation

Before connecting a pressure regulator to a full cylinder always screw out (anticlockwise) the regulation screw. This ensures that there will be no gas flow through the regulator upon initially opening the cylinder valve, reducing strain on the regulator's internal safety component (known as a diaphragm) and increasing the lifespan of the regulator.

Remove the plastic dust seal from the cylinder valve. Before attaching the regulator/flowmeter, ensure the cylinder valve outlet is free from any impurities that could block the orifices or damage the seats. Briefly open then immediately close the valve, directing the outlet away from both people and any potential sources of ignition. Clean the outlet with a lint-free cloth.

If grit, dirt, oil or dirty water enters the cylinder valve outlet, this may cause damage to the valve internals and result in leakage.

⚠ Match the regulator/flowmeter to the cylinder. Never connect a regulator/flowmeter designed for a particular gas or gases to a cylinder containing any other gas.

To attach the regulator/flowmeter:

1. Attach the inlet of the regulator/flowmeter to the cylinder, securing it snugly with a proper wrench, but avoid over-tightening. Regulator connections can be fully threaded in by hand and then only require a fraction of a turn to achieve a gas tight seal.
2. Secure the outlet hose tightly, then connect any downstream equipment.
3. For downstream equipment that is sensitive, consider the installation of an additional safety device if the regulator/flowmeter does not include a built-in pressure relief feature.

Operation

Once the regulator/flowmeter is connected to the cylinder with the regulation screw completely disengaged, follow these steps to pressurise:

1. Position yourself to the side of the regulator/flowmeter and gradually open the cylinder valve. Rapid opening can cause a sudden pressure increase, potentially damaging the internal components of the regulator/flowmeter.
2. Ensure all valves on the downstream equipment are closed, then set the regulator/flowmeter to the desired working pressure.

i It's advisable to perform a leak test at the connection points of the regulator/flowmeter using an appropriate leak detection solution or soapy water.

3. Purge any air or non-essential welding grade shielding gas from the system attached to the regulator/flowmeter by briefly opening and then closing each control valve. The duration of the purge process could last as long or longer than ten seconds, depending on both the length and diameter of the hose being cleared.

To adjust the operational flow rate of the regulator/flowmeter:

1. Slowly turn the regulator/flowmeter's regulation screw (clockwise) until the outlet gauge shows the desired flow rate.

i It might be necessary to re-evaluate the flow rate of the shielding gas through the regulator/flowmeter after completing an initial series of welds, as back pressure within the shielding gas hose assembly can affect readings.

2. To decrease the flow rate, first ensure the welding-grade shielding gas is safely vented from the regulator/flowmeter by opening the downstream valve. Direct the released gas to a well-ventilated area, away from any potential sources of ignition. Then, adjust the screw (anticlockwise) until the gauge reflects the desired flow rate. Finally, shut the downstream valve.

Shutdown

Always close the cylinder valve when the regulator/flowmeter is not in use. For shutdowns lasting longer than 30 minutes, follow these steps:

1. Close the gas cylinder or upstream valve.
2. Open downstream equipment valves to purge the lines, directing the gas to a well-ventilated area, and away from ignition sources.
3. Once the gas is fully vented, turn the regulation screw to its closed position and close the valves on the downstream equipment.
4. Prior to moving cylinders that are not fixed on a specifically designed trolley, detach the regulators/flowmeters.

7. Operation

7.1 Preparing for Operation

Before using the equipment, ensure that all the necessary installation actions have been completed according to your equipment setup and instructions.

i Industry standards typically dictate the minimum and maximum welding capacity and are influenced by practical considerations for both single-pass and multi-pass welds to secure the best possible quality. The material thicknesses indicated on this machine are subject to these standards and best practices for the weld being performed.

i Always check before use that the torch cable, shielding gas hose, earth cable/clamp and power cable are in serviceable condition. Ensure that the connectors are correctly fastened. Loose connectors can impair welding performance and damage connectors.

Connect the plug into the mains socket, then switch the power source ON.

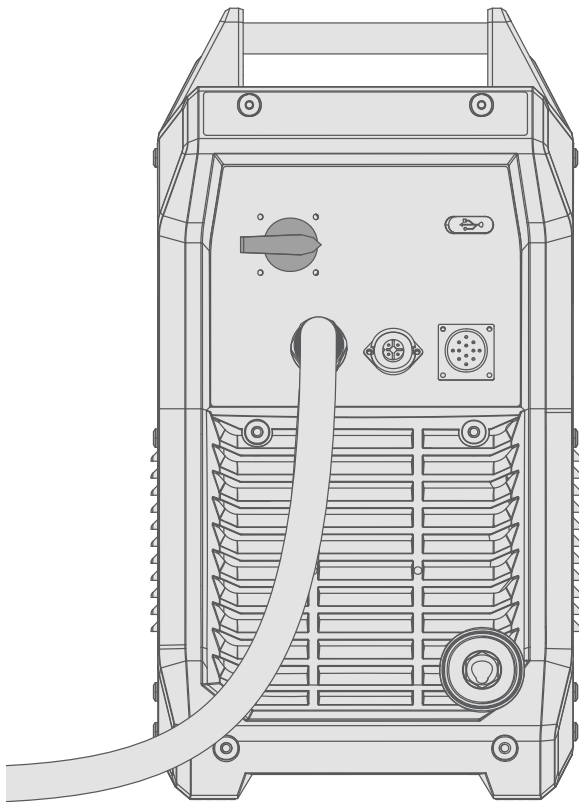

7.2 Control Panel Layout & Operation

Machine

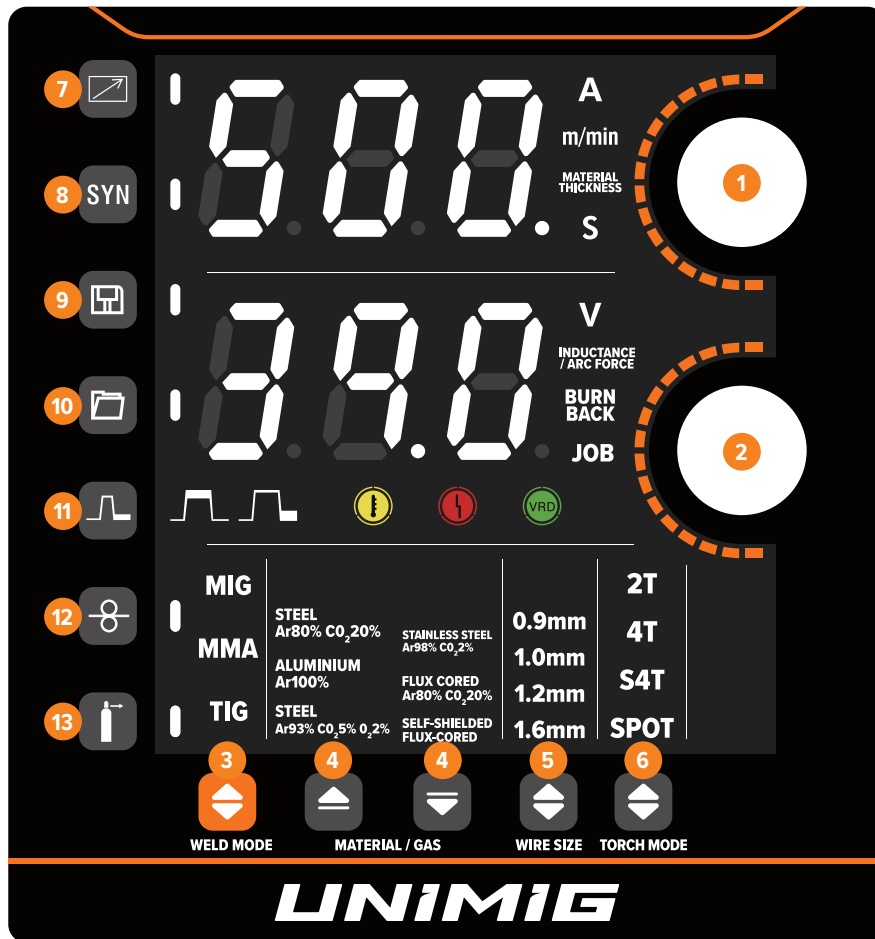

1. Top control knob

- Turn this knob to adjust the parameter value.
- Press this knob to cycle through the parameters.

2. Bottom control knob

- Turn this knob to adjust the parameter value.
- Press this knob to cycle through the parameters.

3. Weld Mode button

Press this button to cycle between weld modes.

4. Material/Gas buttons

Press these buttons to cycle between the material and gas programs.

5. Wire Size button

Press this button to cycle between the wire diameters.

6. Torch Mode button

Press this button to cycle between torch trigger modes.

7. Remote Mode button

Press this button to enter Remote Mode.

8. Synergic Mode button

Press this button to enter Synergic Mode.

9. Job Storage button

Press this button to save the current parameters as a Job.

10. Job Recall button

Press this button to open the saved Jobs menu.

11. Crater Fill button

Press this button to cycle between the main weld's values and crater fill values.

12. Wire Inch button

Press this button to feed the wire through the torch.

13. Gas Test button

Press this button to activate the gas.

SWF



1. Top control knob

- a. ↻ **Turn** this knob to adjust the parameter value.
- b. ⏪ **Press** this knob to cycle through the parameters.

2. Bottom control knob

- a. ↻ **Turn** this knob to adjust the parameter value.
- b. ⏪ **Press** this knob to cycle through the parameters.

3. Weld Mode button

⏪ **Press** this button to cycle between weld modes.

4. MIG Mode button

⏪ **Press** this button to cycle between MIG torches.

5. Torch Mode button

⏪ **Press** this button to cycle between torch trigger modes.

6. Crater Fill button

⏪ **Press** this button to cycle between the main weld's values and crater fill values.

7. Synergic Mode button

⏪ **Press** this button to enter Synergic Mode.

8. Lock button

⏪ **Press** this button to lock the power source screen. Settings can only be adjusted from the SWF screen when the lock is on.

7.3 MIG Mode



1. **Press** the Weld Mode button to cycle through and select MIG.
2. **Press** the Material/Gas button to cycle through and select the material & gas types.
3. **Press** the Wire Size button to cycle through and select the wire diameter.
4. **Press** the Torch Mode button to cycle between 2T, 4T, S4T and SPOT torch modes.
5. **Turn** the top control knob to adjust the Wire Feed Speed, Amperage or Material Thickness
6. **Press** the bottom control knob to cycle between Voltage, Inductance and Burnback. **Turn** it to adjust these parameters.

7.3.1 Welding Parameters

Parameter	Value	Description
Material/Gas	<ul style="list-style-type: none"> • Steel Ar80% / CO₂20% • Aluminium Ar100% • Steel Ar93% / CO₂5% / O₂2% • Stainless Steel Ar98% / CO₂2% • Flux-Cored Ar80% / CO₂20% • Self-Shield Flux-Cored 	Select the wire type & gas mixture being used.
Wire Size	0.8mm - 1.6mm	Select the wire diameter being welded.

Parameter	Value	Description
Torch Mode	2T / 4T / S4T / SPOT	<p>Switch between torch trigger modes:</p> <p>Torch Mode 2T Initiates welding when the torch trigger is pressed and stops when released.</p> <p>Torch Mode 4T Press the torch trigger once to start welding and release it. Press again to stop the weld. This mode is useful for longer welds and reducing hand fatigue.</p> <p>Torch Mode S4T Adjust the welding current while welding with Special 4T torch mode.</p> <p>Press the torch trigger to start welding at the Start Amp value. Release it to increase to the Peak Amp value.</p> <p>Press and hold the torch trigger to decrease to the End Amp value. Release it to increase back to the Peak Amp value.</p> <p>Double press the torch trigger to end the weld.</p> <p>Spot Mode Spot mode provides precision in creating timed weld spots with controlled intervals and counts. It's ideal for consistent tacking or producing uniform joins across materials.</p>
Crater Fill	Standard / Crater	<p>Calculates optimal settings based on the selected Wire, Gas, Wire Diameter and Material Thickness (Amperage).</p> <p><i>Only available in 4T & S4T torch modes.</i></p>
Synergic	Off / On	Calculates optimal settings based on the selected Wire, Gas, Wire Diameter and Material Thickness (Amperage).
MIG Mode	Standard MIG / Push Pull Gun / Spool Gun	Select the MIG torch being used.

7.3.2 Advanced Welding Parameters

Parameter	Value	Default Value	Description
Wire Feed Speed	1.8m/min - 24m/min (RAZOR SWF 350) 2m/min - 24m/min (RAZOR SWF 500)	5m/min	Sets the wire feed speed while welding.
Material Thickness	1mm - 16mm	N/A	<p>Sets the material thickness being welded.</p> <p><i>Only available in Synergic Mode.</i></p>
Voltage	10V - 40V (RAZOR SWF 350) 10V - 48V (RAZOR SWF 500)	19V	Sets the voltage while welding.
Voltage Adjustment	-8 - 8	0	<p>Sets the voltage adjustment while in synergic MIG modes.</p> <p><i>Only available in Synergic Mode.</i></p>
Inductance	-10 - 10	0	Sets the inductance level, which controls the arc's smoothness and spatter.
Burnback	100ms - 800ms (RAZOR SWF 350) 0ms - 800ms (RAZOR SWF 500)	200ms	Sets how long the wire will stay charged after feeding stops, ensuring the wire end is clean for the next start, reducing the risk of wire sticking to the workpiece.
Spot Timer	0.1s - 10s	0.1s	Sets the duration for each spot weld.

 **The settings available in the advanced welding parameters screen will depend on the standard welding parameters selected.**

7.4 MMA Mode



1. **Press** the Weld Mode button to cycle through and select MMA.
2. **Turn** the top control knob to adjust the Amperage.
3. **Press** and **turn** the bottom control knob to select and adjust the Arc Force.

7.4.1 Welding Parameters

Parameter	Value	Default Value	Description
Amperage	20A - 350A (SWF 350) 20A - 500A (SWF 500)	130A	Sets the maximum amperage while welding.
Arc Force	0 - 100	40	The level of current boost when the machine senses voltage drops, improving arc stability and preventing electrode sticking.

7.5 TIG Mode





1. **Press** the Weld Mode button to cycle through and select TIG.
2. **Turn** the top control knob to adjust the amperage.



7.5.1 Welding Parameters

Parameter	Value	Default Value	Description
Amperage	20A - 350A (SWF 350) 20A - 500A (SWF 500)	100A	Sets the maximum amperage while welding.

7.6 Job Menu

1.  **Press** the Job Recall button to open the Job Menu screen.
2.  **Turn** the control knob to choose an option.  **Press** to select it.



7.6.1 Saving a Job

1. On the weld screen and parameters you want to save,  **press** the Job Storage button.
2.  **Turn** the control knob to choose from slots n01-n10.
3.  **Press** the Job Storage button again to save the job.

7.6.2 Overwriting a Job

To overwrite a job, follow the steps for Saving a Job and select the Job number you want to save over.

7.6.3 Loading a Job

1.  **Press** the Job Recall button to open the Job Menu screen.
2.  **Turn** the control knob to choose a job from n01-n10.
3.  **Press** the Job Recall button to load the saved job.

7.7 System Settings

1. **Press** and hold the top control knob for 2 seconds. A 3 second countdown timer will appear on the screen. Continue holding the control knob until the countdown ends.
2. **Turn** the top control knob to cycle through the settings.
3. **Press** the top control knob to select a setting.
4. **Turn** the bottom control knob to adjust the setting.
5. **Press** the top control knob to save the setting.
6. **Press** the Weld Mode button to exit the settings screen.

Setting	Value	Default Value	Description
F01 Standby Timer	0, 5, 10, 15	10	<p>Sets the standby timer. The unit value is minutes, with 0 disabling the standby timer.</p> <p>If the machine is not used within the set time, it will enter standby mode, during which only the middle bar of the first digit on the display panel will flash.</p> <p>The machine will exit standby mode when the torch trigger or operation panel is used.</p>
F02 Pre-flow Timer	0 - 2.0s (MIG) 0 - 5.0s (TIG)	Off	Sets the duration of shielding gas released before the arc ignites.
F03 Post-flow Timer	0 - 5.0s (MIG) 0 - 10.0s (TIG)	Off	Sets the duration of shielding gas released after the welding arc stops.
F04 Down Slope Timer	0 - 5.0s	Off	Sets the time the welding current takes to decrease from the main welding current.
F05 Burnback Voltage	10 - 20s	Off	<p>Sets how long the wire will stay charged after feeding stops, ensuring the wire end is clean for the next start, reducing the risk of wire sticking to the workpiece.</p> <p>The default burnback voltage for aluminium is 11.0V and for steels is 13.0V.</p>
F06 MMA Hot Start Current	0 - 200A	100A	Sets the amount of initial boost in the welding current. Hot Start boosts the initial welding current for a short duration to ensure a reliable arc start.
F07 Slow Wire Feed Speed	1.4 - 18m/min	Off	<p>Sets the MIG slow wire feed speed.</p> <p>The default value varies depending on the weld process and is represented as Off.</p>
F08 Welding Soft Start Time	1 - 200ms	Off	Sets the MIG soft start time.
F09 Remote Mode	0, 1	0	<p>Sets the machine to wired or wireless remote control mode.</p> <p>0 = wireless remote mode 1 = wired remote mode</p>
F10 Water/Air Cooling Mode	0, 1	0	<p>Sets the cooling mode of the welding torch.</p> <p>0 = air-cooled 1 = Water-Cooled</p>
F11 Smart Gas-saving	0, 1	0	<p>Sets the smart gas-saving on or off.</p> <p>0 = off 1 = on</p>

Setting	Value	Default Value	Description
F12 Default Synergic Display	1, 2, 3	1	Sets the default display readout when in synergic mode. 1 = current displayed by default 2 = speed displayed by default 3 = material thickness displayed by default
F13 Control Board Software Version			The initial version is 1.00, and later versions are 1.01, 1.02, and so on.
F14 Display Board Software Version			The initial version is 1.00, and later versions are 1.01, 1.02, and so on.

 **The settings available will depend on the Weld Mode selected when the System settings were entered.**

Restore Default Settings

-  **Press** and hold the Weld Mode button for 2 seconds. A 3 second countdown timer will appear on the screen. When the countdown ends, the default settings will be restored.
- Continue holding the button until the countdown ends.

Releasing the button before the countdown ends will cancel the factory reset.

8. Maintenance

How often the machine is used and the working environment it is in should both be considered when planning the frequency of maintenance. In severe conditions, maintenance should occur more frequently.

Proper operation of the machine and regular preventive maintenance will help avoid equipment failure, increase the life-span of the machine and ensure problem-free welding.

⚠ Turn the machine off and unplug it from the mains before beginning any maintenance.

Before each use, check your gas hose, earth clamp and cable, and power cable are in good condition. Check that all connections are properly fastened. Any loose connections can inhibit welding performance and cause damage.

- Check that all covers and components are intact.
- Check all electrical cables and connections every 6 months.
- Clean any oxidised connections and tighten them.
- Clean dirt and dust from the outside and inside of the unit with a vacuum cleaner and soft brush.

ⓘ Do not use any pressure-washing devices. Do not use compressed air, the pressure may pack the dirt even more tightly into components.

⚠ Only authorised electricians or service repair agents should carry out repairs and internal servicing.

For repairs, contact UNIMIG at unimig.com.au or contact your local dealer.

9. Troubleshooting

i The issues and potential reasons outlined are not exhaustive but indicate common scenarios that might arise with regular use of the machine.

9.1 Machine Troubleshooting

Problem	Recommended Actions
The machine does not power up	<ul style="list-style-type: none"> • Check that the power cable is plugged in properly. • Check that the mains switch of the power source is at the ON position. • Check that the mains power distribution is on. • Check the mains fuse and/or the circuit breaker.
The machine stops working	<ul style="list-style-type: none"> • The torch may have overheated. Wait for it to cool down. • Check that none of the cables are loose. • The power source may have overheated. Wait for it to cool down and see that the cooling fans work properly and the air flow is unobstructed.

9.2 MIG Troubleshooting

Problem	Recommended Actions
Excessive spatter	<ul style="list-style-type: none"> • The wire feed speed may be too high, select a lower wire feed speed. • The voltage may be too high, select a lower voltage setting. • The polarity may be wrong, check the polarity (see "6.2 Connecting the MIG Torch" on page 23). • The stickout may be too long, bring the torch closer to the workpiece. • Remove materials like paint, grease, oil, and dirt, including mill scale from the base metal. Use clean, dry, rust-free wire. Do not lubricate the wire with oil, grease etc. • The gas flow may be wrong, check the gas is connected, check hoses, gas valve and torch are not restricted or leaking. Set the gas flow to the recommended flow rate.
Porosity	<ul style="list-style-type: none"> • Check that the correct gas is being used. The gas flow may be wrong, check the gas is connected, check hoses, gas valve and torch are not restricted or leaking. Set the gas flow to the recommended flow rate. Protect the welding zone from wind and drafts. • Remove all moisture from the base metal before welding. • Remove materials like paint, grease, oil, and dirt, including mill scale from the base metal. Use clean, dry, rust-free wire. Do not lubricate the wire with oil, grease etc. • The gas nozzle may need to be cleaned or replaced. • Check the gas diffuser is in place and replace if damaged. • Check the MIG torch Euro connect O-ring is in place and replace if damaged.
Wire stubbing during welding	<ul style="list-style-type: none"> • Bring the torch closer to the workpiece and maintain a stickout of 5-10mm. • The voltage may be too low, increase the voltage. • The wire feed speed may be too high, decrease the wire feed speed.

Problem	Recommended Actions
Lack of fusion	<ul style="list-style-type: none"> • Remove materials like paint, grease, oil, and dirt, including mill scale from the base metal. • Select a higher voltage range and/or adjust the wire speed to increase the heat input. • The welding technique being used may be incorrect (See <i>"MIG Welding Basics"</i> on page 77).
Lack of penetration	<ul style="list-style-type: none"> • The joint preparation may be incorrect, or the material is too thick. The joint preparation and design should allow access to the bottom of the groove while maintaining proper welding technique. • Select a higher voltage range and/or adjust the wire speed to increase the heat input. • Reduce the travel speed. • Remove materials like paint, grease, oil, and dirt, including mill scale, from the base metal.
Excessive penetration/Burnthrough	<ul style="list-style-type: none"> • Select a lower voltage range and/or adjust the wire speed to lower the heat input. • Increase the travel speed.
The wire doesn't feed	<ul style="list-style-type: none"> • Check that the weld mode is set to the MIG position. • Check that the torch selection is set to the 'standard' position for MIG welding and 'spool gun' when using the spool gun.
Inconsistent/interrupted wire feeding	<ul style="list-style-type: none"> • The polarity may be wrong, check the polarity (see <i>"6.2 Connecting the MIG Torch"</i> on page 23). • The wire feed speed or voltage settings may be incorrect. • The MIG torch lead may be too long for the wire, small diameter or soft wires like aluminium don't feed well through long torch leads. • Remove any kinks in the MIG torch and reduce any sharp angles. The torch should be held as straight as possible. • Check the contact tip is the correct size and type. • The liner maybe be worn or clogged, try to clear the liner as a temporary measure. It is recommended to replace the liner. • Check the liner is the correct size and type. • Clear or replace the inlet guide tube if it's blocked or worn. • Check the wire is properly lined up in the drive roller groove. • Check the drive rollers are the correct size and type and that they're not worn. • Check the drive roller pressure - See <i>"6.13 Installing & Replacing the Wire"</i> on page 38 for how to correctly tension the rollers. • Check the tension on wire spool hub. • Check the wire isn't crossed over or tangled, if it is, remove the spool and untangle or replace the wire. • Use clean, dry, rust-free wire. Do not lubricate the wire with oil, grease etc.

9.3 TIG Troubleshooting

Problem	Recommended Actions
Tungsten burning away quickly	<ul style="list-style-type: none"> • Check that the correct gas is being used. • Check the gas is connected, check hoses, gas valve and torch are not restricted or leaking. Set the gas flow to the recommended flow rate. • Check the back cap is fitted correctly and that the O-ring is inside the torch body. • The polarity may be wrong, check the polarity (See "6.6 Connecting the TIG Torch (optional)" on page 30). • Check the right tungsten is being used and change the tungsten type if necessary. • Keep the shielding gas flowing 10-15 seconds after arc stoppage to prevent tungsten oxidation.
Contaminated tungsten	<ul style="list-style-type: none"> • Don't let the tungsten touch the weld pool. Raise the torch so that the tungsten is off the workpiece 2-5mm. • Don't let filler rod touch the tungsten during welding. Feed the filler rod into the leading edge of the weld pool in front of the tungsten.
Porosity	<ul style="list-style-type: none"> • Check that the correct gas is being used. • Check the gas is connected, check hoses, gas valve and torch are not restricted or leaking. Set the gas flow to the recommended flow rate. • Remove materials like paint, grease, oil, and dirt, including mill scale, from the base metal & filler rod. • Check the filler rod is correct and change if necessary.
Yellowish residue/smoke on the ceramic cup & discoloured tungsten	<ul style="list-style-type: none"> • Check that the correct gas is being used. • Check the gas is connected, check hoses, gas valve and torch are not restricted or leaking. Set the gas flow to the recommended flow rate. • The cup size may be too small, use a bigger cup size.
Unstable arc while welding	<ul style="list-style-type: none"> • The polarity may be wrong, check the polarity (See "6.6 Connecting the TIG Torch (optional)" on page 30). • Remove materials like paint, grease, oil, and dirt, including mill scale, from the base metal. • The tungsten may be contaminated, remove 10mm of the contaminated tungsten and re-grind the tungsten. • The arc length may be too long, lower the torch so that the tungsten is off the workpiece 2-5mm.
Arc wandering while welding	<ul style="list-style-type: none"> • Check the gas is connected, check hoses, gas valve and torch are not restricted or leaking. Set the gas flow to the recommended flow rate. • The amperage may be too low, increase the amperage. • The arc length may be too long, lower the torch so that the tungsten is off the workpiece 2-5mm. • Check that correct type of tungsten is being used and it's not contaminated. Remove 10mm of the contaminated tungsten and re-grind the tungsten. • The tungsten may be poorly prepared. Grind marks should run lengthwise with tungsten, not circular. • Remove materials like paint, grease, oil, and dirt, including mill scale, from the base metal & filler rod.
Arc difficult to start or won't start	<ul style="list-style-type: none"> • Check the machine set up is correct. • Check that the correct gas is being used. • Check the gas is connected, check hoses, gas valve and torch are not restricted or leaking. • Check the right type & size tungsten is being used and change the tungsten type if necessary. • Check all the connections are tight. • Connect the earth clamp directly to the workpiece.

9.4 MMA Troubleshooting

Problem	Recommended Actions
No arc	<ul style="list-style-type: none"> • Check the earth lead and all connections are tight. • Check that the machine is switched on and has a power supply. • Check that the weld mode is set to the MMA position.
Porosity	<ul style="list-style-type: none"> • The arc length may be too long, move the electrode closer to the workpiece. • Remove materials like paint, grease, oil, and dirt, including mill scale, from the base metal. • Only use dry electrodes.
Excessive spatter	<ul style="list-style-type: none"> • The amperage may be too high, reduce the amperage. • The arc length may be too long, move the electrode closer to the workpiece.
Lack of fusion	<ul style="list-style-type: none"> • The amperage may be too low, increase the amperage. • Remove materials like paint, grease, oil, and dirt, including mill scale, from the base metal. • Use the correct welding technique (See "13. MMA Welding Guide" on page 88).
Lack of penetration	<ul style="list-style-type: none"> • The amperage may be too low, increase the amperage. • Use the correct welding technique (See "13. MMA Welding Guide" on page 88). • Check the joint design and fit up is correct and the material isn't too thick.
Excessive penetration/Burnthrough	<ul style="list-style-type: none"> • The amperage may be too high, reduce the amperage. • Increase the travel speed.
Uneven weld appearance	<ul style="list-style-type: none"> • Use two hands where possible to hold the electrode steady. • Use the correct welding technique (See "13. MMA Welding Guide" on page 88).
Distortion	<ul style="list-style-type: none"> • The amperage may be too high, reduce the amperage. • Use the correct welding technique - (See "13. MMA Welding Guide" on page 88). • Check the joint design and fit up is correct and the material isn't too thick.
Unusual or poor arc characteristics	<ul style="list-style-type: none"> • The polarity may be wrong, check the polarity (See "6.7 Connecting the MMA Electrode Holder" on page 31).

9.5 Error Codes

Error Code	Name	Description	Potential Action
E10	Overcurrent protection	The machine output is exceeding its limit.	Restart the machine. If the problem persists, contact UNIMIG customer service.
E30	Open-phase protection	The power supply has a loss of phase issue.	Restart the machine after it has powered down. Contact an electrician to determine if there is a loss of phase in the power supply. If the power supply is operating as normal, contact UNIMIG customer service.
E31	Under-voltage protection	The input voltage is too low.	Restart the machine. Remove extension leads or try a different outlet. If the problem persists, contact UNIMIG customer service"
E32	Overvoltage protection	The input voltage is too high.	Restart the machine. If the problem persists, contact UNIMIG customer service.
E34	Drive voltage protection	The input voltage to the IGBT circuit is too low.	Restart the machine. If the problem persists, contact UNIMIG customer service.
E60	Primary inverter overheating protection	The temperature of the primary inverter IGBT is too high.	Do not turn off the machine. Wait for the machine to cool down and the indicator to stop displaying. If the indicator remains after the machine has cooled, contact UNIMIG customer service.
E61	Secondary inverter overheating protection	The temperature of the secondary inverter IGBT is too high.	Do not turn off the machine. Wait for the machine to cool down and the indicator to stop displaying. If the indicator remains after the machine has cooled, contact UNIMIG customer service.
E71	Water cooler alarm	The water cooler is not connected. The water cooler unit does not have enough coolant. The water cooler is overheating.	Check the water cooler wiring and that it is connected to the machine properly. Add more coolant. If there is coolant in the unit, check the water cooler wiring and the motor is running. Wait for the water cooler to cool down. If the problem persists, contact UNIMIG customer service.
U01	Hall open-circuited	The output current hall sensor circuit is open.	Check the hall sensor wiring is properly connected and in good condition. If the problem persists, contact UNIMIG customer service.
U02	Output short-circuit on the welder side	The output circuit of the machine has short-circuited.	Check all connections, cables, consumable parts and the earth clamp to ensure nothing could cause a short circuit and restart the machine. If the problem persists, contact UNIMIG customer service.
U03	Encryption key abnormal	The machine software encryption key has not been verified properly.	Restart the machine after it has powered down. If the problem persists, contact UNIMIG customer service.
U04	Startup data reading abnormality	There is an error in the data stored by the single-chip microcomputer.	Restart the machine after it has powered down. If the problem persists, contact UNIMIG customer service. ⓘ After the error has displayed for 10 seconds, the machine will resume normal operation, but the alarm indicator 🚫 will remain on.
U05	Fan abnormality	The fan's power supply circuit is disrupted.	Check the fan cable wiring is properly connected and in good condition and restart the machine. If the problem persists, contact UNIMIG customer service. ⓘ After the error has displayed for 10 seconds, the machine will resume normal operation, but the alarm indicator 🚫 will remain on.

Error Code	Name	Description	Potential Action
U06	Gas valve abnormality	The gas valve's power supply circuit is disrupted.	<p>Check the gas valve cable wiring is properly connected and in good condition and restart the machine. If the problem persists, contact UNIMIG customer service.</p> <p>After the error has displayed for 10 seconds, the machine will resume normal operation, but the alarm indicator will remain on.</p>

9.6 Indicator Lights

Thermal Overload

Indicates that the machine has overheated. This is generally caused by the duty cycle being exceeded. Wait for the machine to cool down.

Alarm Indicator

Indicates that the machine has experienced an internal fault.

VRD

When green, this indicates that the VRD is on and operating as normal.
When red, this indicates that the VRD is off or experiencing a fault.

10. General Welding Information

10.1 Metal Preparation

Proper preparation of the metal surface is crucial for achieving a good quality weld and cannot be overstated. Each type of metal may require slightly different approaches, especially in terms of cleaning and edge preparation, to adapt to its specific properties and behavior during welding.

Mild Steel

- **Cleaning:** Start by removing any rust, paint, oil, or grease from the surface. Use a wire brush or grinder to clean the metal. It's essential to start with a clean surface to avoid contamination of the weld pool.
- **Degreasing:** Wipe down the surface with a solvent such as acetone or a commercial degreaser to remove any residual oils or contaminants that might interfere with the welding process.
- **Edge Preparation:** If welding thicker pieces, bevel the edges to allow the weld to fully penetrate the joint. The angle and depth of the bevel depend on the thickness of the metal.
- **Fit up:** Ensure that the pieces to be welded fit together well without large gaps. A good fitup helps achieve a strong and uniform weld.

Stainless Steel

- **Cleaning:** Similar to mild steel, all surfaces must be cleaned of any contaminants. Use a stainless steel wire brush (one dedicated to stainless steel to avoid cross-contamination with other metals) to remove any surface debris.
- **Degreasing:** Clean the surface with a high-purity solvent like acetone to remove any oils or residues. This step is crucial for stainless steel to prevent any interference with the weld quality.
- **Edge Preparation:** Bevel the edges if necessary, especially for thicker pieces. Stainless steel requires precise edge alignment to ensure a quality weld, so take extra care during this step.
- **Avoiding Contamination:** Use dedicated tools for stainless steel to avoid iron contamination from regular steel tools. This can lead to rust and corrosion.

Aluminium

- **Cleaning:** Aluminium oxidises very quickly when exposed to air. Use a stainless steel wire brush to remove the oxide layer just before welding, as this layer can contaminate the weld pool if not removed.
- **Degreasing:** Clean the metal with a solvent like acetone immediately after brushing to ensure that no oils or moisture are present, which can cause porosity in the welds.
- **Edge Preparation:** Beveling may be necessary depending on the thickness of the metal. Aluminium requires careful preparation as it is more sensitive to heat and can warp easily.
- **Drying:** Aluminium has a high affinity for moisture, so ensure that the metal is completely dry before welding. Moisture can lead to hydrogen porosity in the weld.

10.2 Beveling

The standard bevel for pipe and plate in welding is primarily determined by the thickness of the materials and the type of weld joint being prepared. Beveling is done to ensure that the weld can fully penetrate the joint, which is crucial for the structural integrity of the weld. It is primarily used to prepare butt joints for welding.

Here's a general breakdown of typical bevels used for both pipes and plates:

Thickness below 3mm: Typically, no beveling is required for material thinner than 3mm. A square butt joint is usually sufficient as the weld can penetrate through the entire thickness.

Thickness 3mm to 12mm: A single-V bevel is often used. The angle might start from about 30° for thinner sections up to about 37.5° for closer to 12mm thick material.

Thickness above 12mm: Double-V bevels become more common as the thickness increases, reducing the amount of filler material needed and ensuring better weld penetration.

The specific bevel angle and type also depend on the welding standards being followed (such as AWS, ASME, etc.), the welding process used, and the requirements of the specific project or industry. For precise applications, always refer to the welding specification or consult a welding engineer to determine the most appropriate bevel for a given situation.

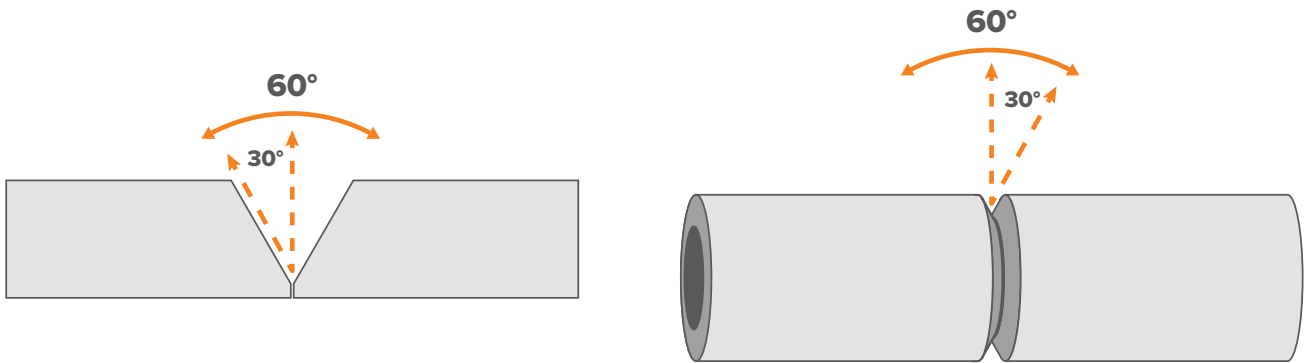

11. MIG Welding Guide

What is MIG Welding?

Metal Inert Gas (MIG) welding is an arc welding process in which a solid wire electrode is continuously fed through a welding gun into a weld pool. An arc is formed between the wire electrode and base metal, melting the base material while consumable filler wire is deposited, creating the weld.

At the same time, a shielding gas is fed through the welding torch to protect the weld from outside contaminants.

MIG welding is also known as Gas Metal Arc Welding (GMAW).

MIG welding can be done with both solid wires and flux-cored wires. Flux-cored welding is a variant of MIG welding.

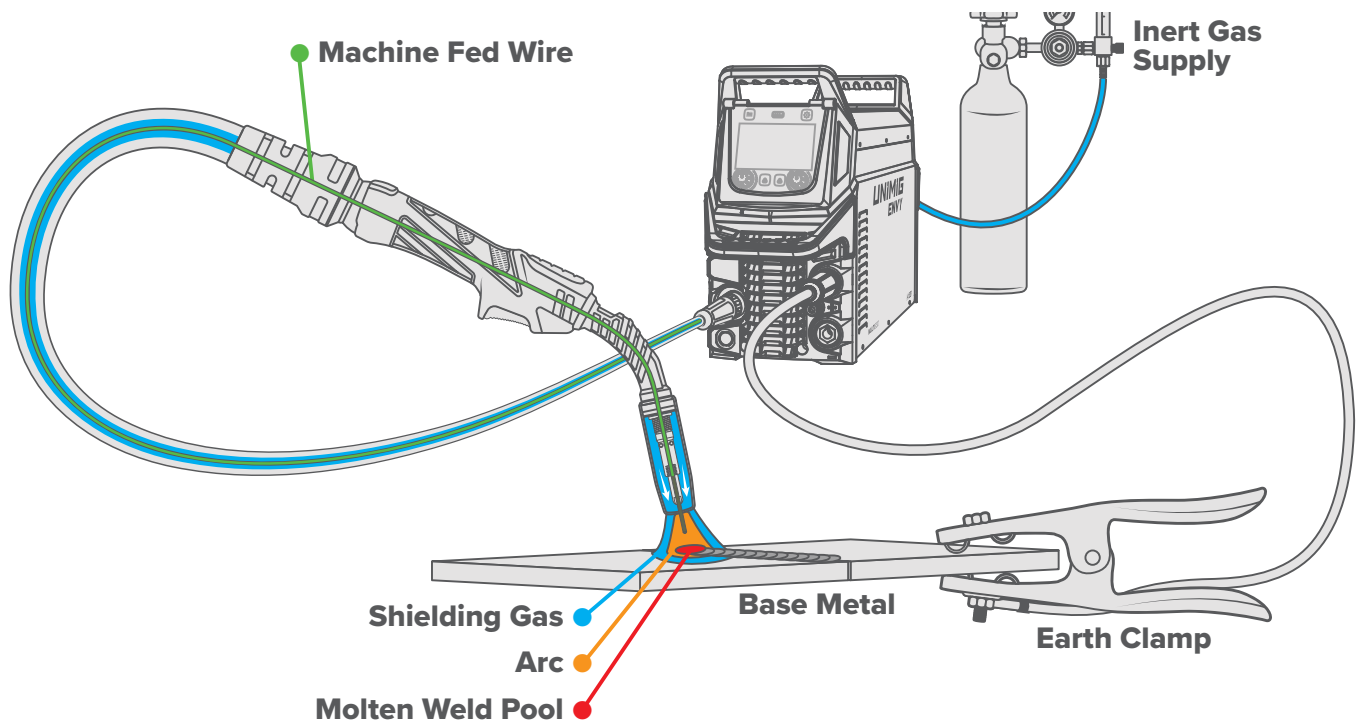

What is Flux-Cored Welding?

Flux-cored welding is an arc welding process where a tubular (hollow) wire electrode is continuously fed through a welding gun into a weld pool. An arc is formed between the wire electrode and base metal, melting the base material while consumable filler wire is deposited, creating the weld.

Flux-cored welding doesn't require a shielding gas. Instead, as the wire melts and deposits metal, the flux compound in the wire dissolves and releases vapours (gases). These gases rise to the surface of the weld pool, where they solidify and create a protective slag layer over the weld.

Flux-cored welding is also known as Flux-Cored Arc Welding (FCAW) and gasless MIG.

How MIG Welding Works

A constant voltage, direct current power source is used with MIG welding. It feeds wire through the driver rollers, into the torch liner and out of the contact tip and nozzle of the MIG torch. When the wire passes through the copper contact tip, it becomes electrically charged with the welding current. The wire comes out of the torch and touches the base metal, creating an arc between the two.

MIG welding is considered a semi-automatic process because the wire feeding is automatic, but the torch movement is done by hand.

There are two main parameters when MIG welding: voltage and wire feed speed.

The voltage determines how much heat is in the weld. Turning it up or down will adjust how much welding current is added to the weld.

The wire feed speed determines how much wire per minute is added to the weld. The more wire that's added, the cooler the weld will be, and vice versa.

Your voltage and wire feed speed generally work in harmony together and will determine the mode of metal transfer.

Modes of Metal Transfer

There are four main ways filler metal can be transferred from the torch into the base:

- Short Circuit
- Globular
- Spray
- Pulse Spray

Short Circuit Transfer

Metal is transferred by the short circuit mode when the wire is fed into and connects with the puddle, shorting the circuit. It is also known as dip transfer.

Short circuit is the most common mode of metal transfer, as it's done with low volts and it can be used in every position – flat, horizontal, vertical, or overhead. It can be run on straight CO₂ or an argon/CO₂ gas mixture.

The wire heats up and begins to form a molten bead, which then separates from the end of the wire and forms a droplet that is transferred into the weld pool. This shorting occurs roughly 20 to 200 times a second which makes the arc appear constant to the human eye.

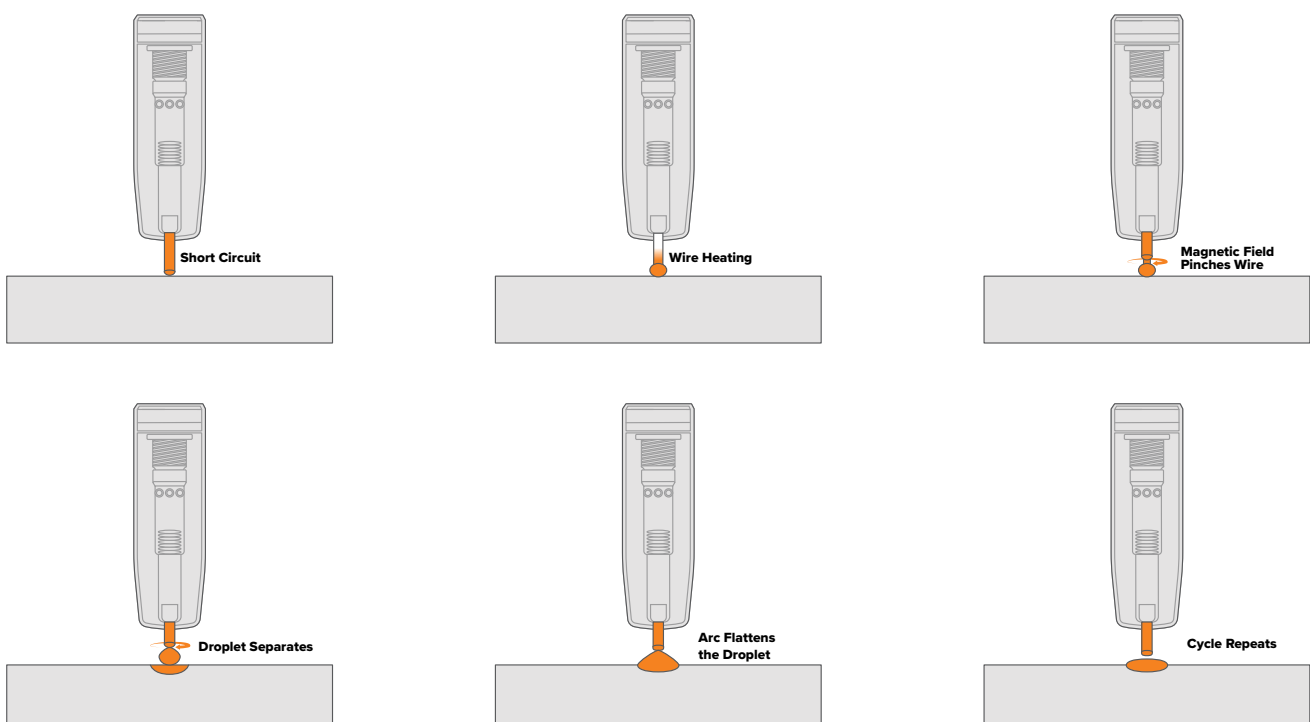

Globular Transfer

Metal is transferred by the globular mode when the wire creates globs of molten metal on the tip that fall into the puddle to make the weld. It looks like a small ball is constantly forming and reforming on the end of your wire. It can be run on straight CO₂ or an argon/CO₂ gas mixture.

Globular is hotter in value, with more wire feed speed and voltage than short circuit, so the weld pool is more fluid. Because the pool is more fluid, it's restricted to flat and horizontal positions only. The bead appearance isn't as smooth, and the process often results in excessive spatter, but it has good penetration.

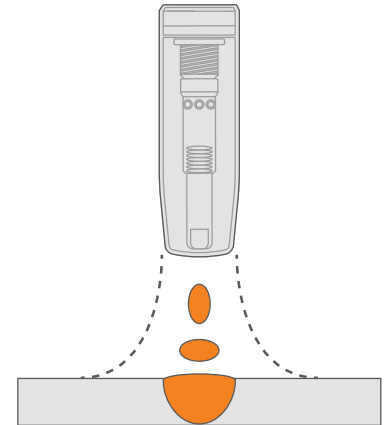

Spray Transfer

Metal is transferred by the spray mode when the amps and voltage are high enough that the wire begins to spray tiny droplets into the pool. These droplets are generally the same size as the wire diameter.

The spray method is usually limited to 6mm or greater thicknesses because of the necessary voltage and wire feed speed needed to move into the spray transfer. Unlike short circuit and globular, it needs to be run on an argon/CO₂ mix of 82% or more.

It's good for heavy fabrication and thick material as it has a deep penetration profile. However, it's so hot and fluid that it's not suitable for vertical up, vertical down, or overhead welding. It's a much cleaner process, though, with almost no spatter.

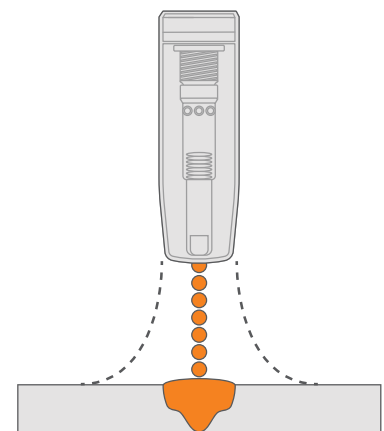

i To MIG weld aluminium, it's recommended to use a pulse welder to do so. If you want to use a constant voltage, you must use the spray transfer mode. It is not possible to MIG weld aluminium using short circuit or globular.

Pulse Spray Transfer

Pulse spray is similar to the standard spray method, but it 'pulses' between the set amps (the peak amps) and a low point. Having a low point means that the weld has a moment to cool each time, making the pulse spray transfer more versatile. Because the weld pool has time to (briefly) cool, it isn't as fluid, so it can be used in more than just flat positions.

Pulse spray still needs an argon/CO₂ gas mix of 82%/18% and it also requires a machine with the ability to pulse MIG.

Pulse MIG Welding

Pulse welding is a form of spray transfer MIG in which the current alternates between a peak current and a base current.

It offers several advantages, including higher welding speeds and deposition rates, a lower heat input, a spatter-free arc, and a smooth weld appearance. Pulse welding is suitable for all welding positions and is particularly effective for welding aluminum and stainless steel, especially when working with thinner materials.

Pulse

Pulse is a welding process where the current alternates between the base current and the pulse current.

Double Pulse

Double pulse is a welding process that involves two distinct pulse levels, with the welding power fluctuating between these levels.

MIG Welding Basics

The quality of your weld and the weld bead profile depends on several factors, including the direction of travel, the travel angle, the wire stickout, the work angle and how fast you travel along your workpiece.

Torch Length

When MIG welding mild or stainless steel, a 4m or 5m torch will work without issue. When MIG welding aluminium, it is recommended to use a 3m torch, as the shorter length helps to reduce potential wire feeding issues.

If more distance is required, for mild and stainless steel (5m+), or aluminium (3m+), a push-pull gun should be used instead. The addition of the motor on the torch allows the wire to be fed longer distances without problems.

Travel Direction

The direction you'll need to travel in will be determined by the type of wire you're using. A push technique should be used when welding with a gas-shielded wire and a pull technique should be used when welding with a flux-cored (gasless) wire.

Push Technique

The push technique is where the wire is located at the leading edge of the weld pool and pushed towards the not yet welded part of the joint. This technique offers a better view of the weld joint and direction of the wire into the weld joint. It directs heat away from the weld puddle, allowing faster travel speeds and providing a flatter and wider weld profile for minimal clean-up.

Pull Technique

The pull or drag technique is where the torch and wire are pulled away from the weld bead. The arc and heat are concentrated on the weld pool. The base metal receives more heat, deeper melting, more penetration, and the weld profile is higher with more build-up.

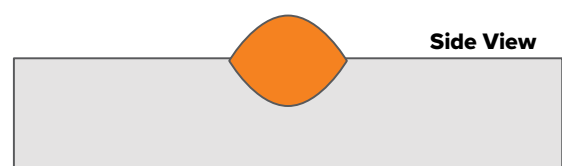
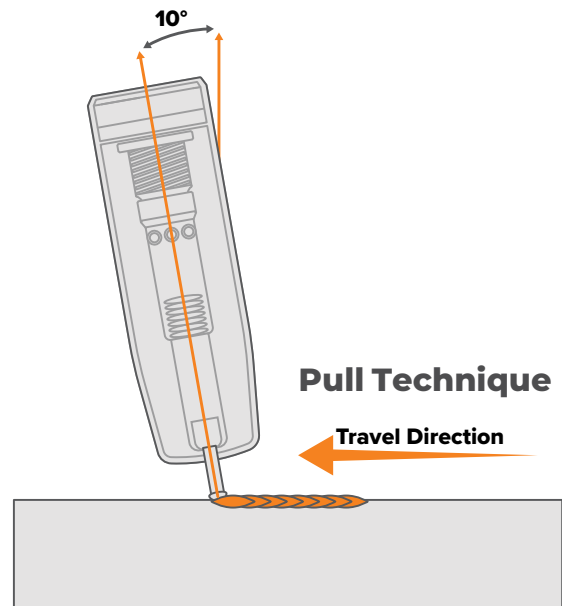
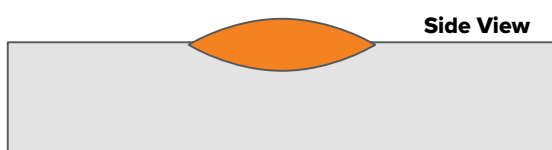
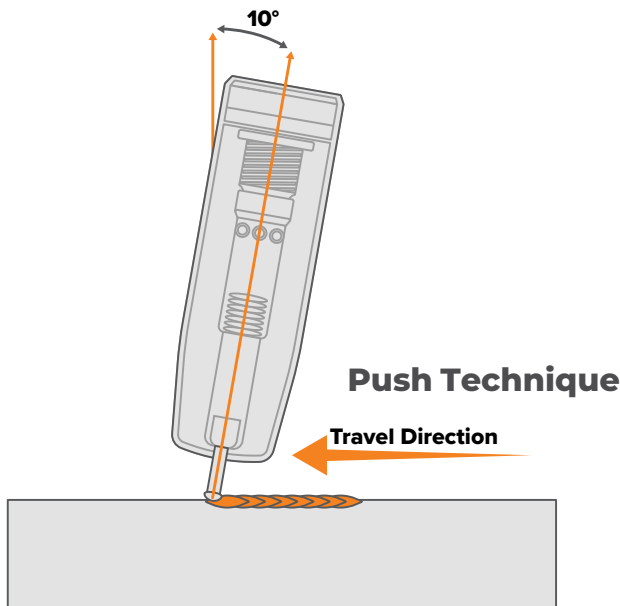

Travel Angle & Distance

The travel angle is the right to left angle of the torch, relative to the direction of welding. Whether you're pushing or pulling, you want to keep your torch at a 10° to 15° angle. If your angle becomes too deep or parallel with the metal you're welding, you increase the spatter amount, decrease penetration, and create more mess that you'll have to clean up later.

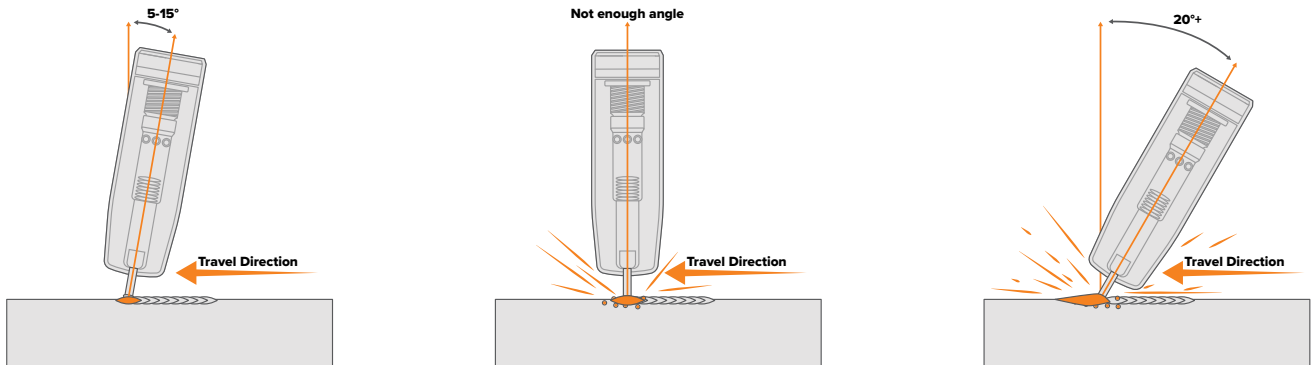

The other important thing to watch is the distance of your wire 'stickout'. The stickout is the length of unmelted wire protruding from the end of the contact tip. You want to maintain the 1cm of stickout throughout the joint for the best weld. If your wire is sticking out too far as it's feeding and your torch nozzle is getting further away from your workpiece, it will cause a few problems.

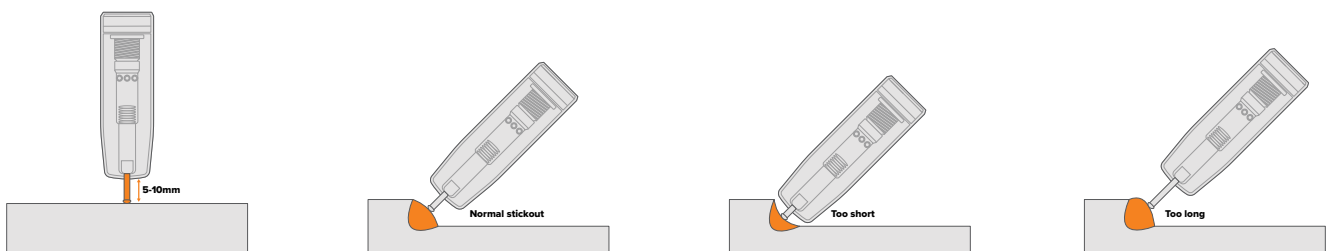

Work Angle

The work angle is the up and down of your torch in relation to the angle of the joint. There are a few different joint types, and several positions these joints can be found.

T-joint / Fillet Joint	Butt Joint	Lap Joint
90° joint angle	180° joint angle	90° joint angle
45° work angle	90° work angle	60°/70° work angle

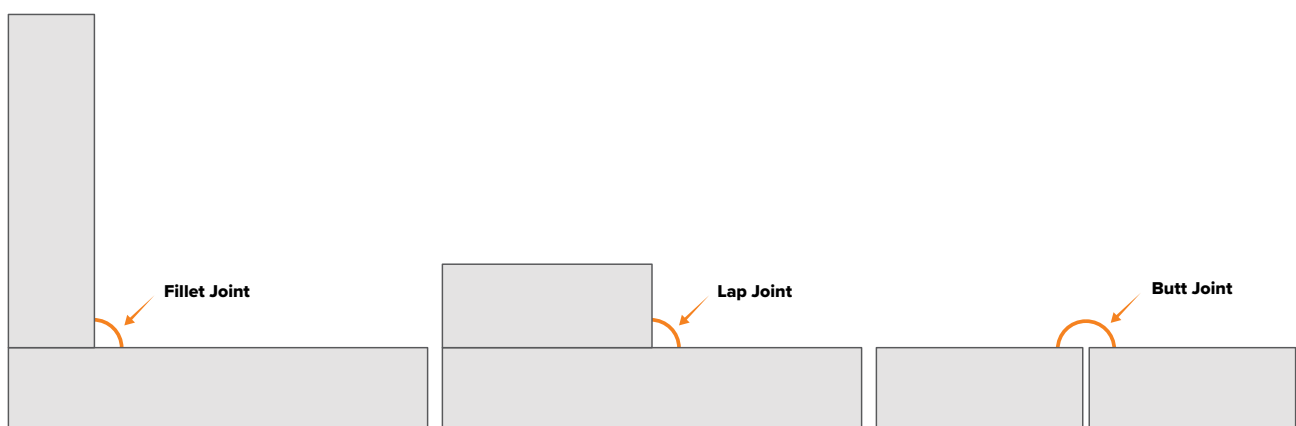

Travel Speed

Travel speed is the rate that the gun is moved along the weld joint and is usually measured in mm per minute. The travel speed needs to match the wire feed speed and will decrease as the material thickness and wire feed speed increase.

Travel Speed Too Fast

Too fast a travel speed produces too little heat, resulting in less penetration and reduced weld fusion. The weld bead solidifies very quickly, trapping gases inside the weld metal and causing porosity. Undercutting of the base metal can also occur, and an unfilled groove in the base metal is created when the travel speed is too fast to allow molten metal to flow into the weld crater created by the arc's heat.

Travel Speed Too Slow

Too slow a travel speed produces a large weld with a lack of penetration and fusion. The energy from the arc dwells on top of the weld pool rather than penetrating the base metal. This produces a wider weld bead with more deposited weld metal than is required, resulting in a weld deposit of poor quality.

Correct Travel Speed

The correct travel speed keeps the arc at the leading edge of the weld pool, allowing the base metal to melt sufficiently to create good penetration, fusion and wetting out of the toes, producing a weld deposit of good quality.

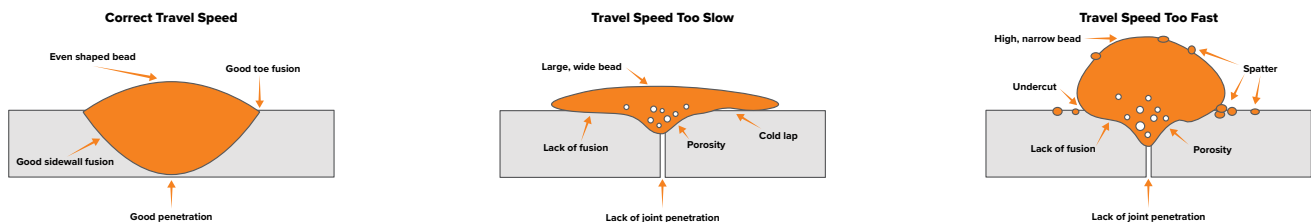

Wire Type & Size

Use the correct wire type for the base metal being welded. Use stainless steel wire for stainless steel, aluminium wires for aluminium and steel wires for steel.

Using poor quality milled wire can result in poor performance and appearance. To ensure optimal performance when welding, use standards approved wire such as UNIMIG HYPERMIG wire.

Use a smaller diameter wire for thin base metals. For thicker materials use a larger wire diameter and larger machine. Check the recommended welding capability of your machine.

Drive Rollers

The drive rollers in the machine help to guide and feed the wire from the spool and out through the torch. They're designed for different metal types, so make sure you're using the correct drive roller for your metal type.

V Groove Drive Rollers

V groove drive rollers are used for solid wires, such as mild and stainless steel. They're characterised by their 'V' shape and aren't knurled or textured. The shape of the roller is ideal for solid wires as it works to feed the wire without it slipping or deforming the wire.

F Groove Drive Rollers

F groove drive rollers, sometimes called knurled drive rollers, are specifically designed for flux-cored (gasless) wires. As their name suggests, these rollers are knurled and can look almost zig-zagged in pattern, or like teeth, in the groove.

These knurls allow the roller to properly grip the wire as it is fed into the torch without any extra tension. That way, the wire isn't distorted through excessive tension and doesn't lose its shape, which can cause feeding issues.

U Groove Drive Rollers

U groove drive rollers are used specifically for aluminium wire, which is a softer wire, so it's more prone to deforming under too much tension. These rollers are also characterised by their 'U' shape and are smooth inside. The U-shaped groove helps to maintain the wire's shape as it is fed through the torch, giving you a smooth wire feed.

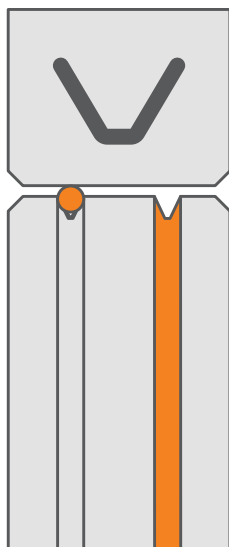

V Groove

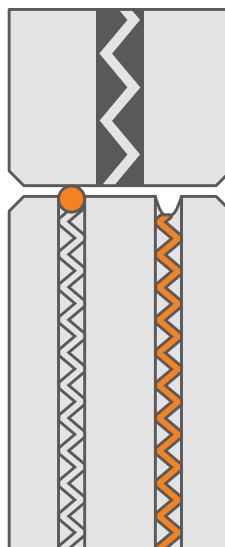

**F (Knurled)
Groove**

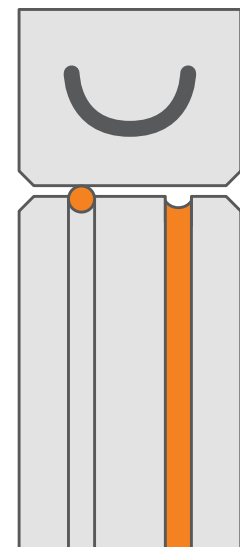

U Groove

12. TIG Welding Guide

What is TIG Welding?

Tungsten Inert Gas (TIG) welding is an arc welding process in which an arc is formed between a non-consumable tungsten electrode and the workpiece to create the weld.

Filler metal is added manually, though it isn't always necessary.

An inert shielding gas is fed through the TIG torch to protect the weld from outside contaminants.

TIG welding is also known as Gas Tungsten Arc Welding (GTAW).

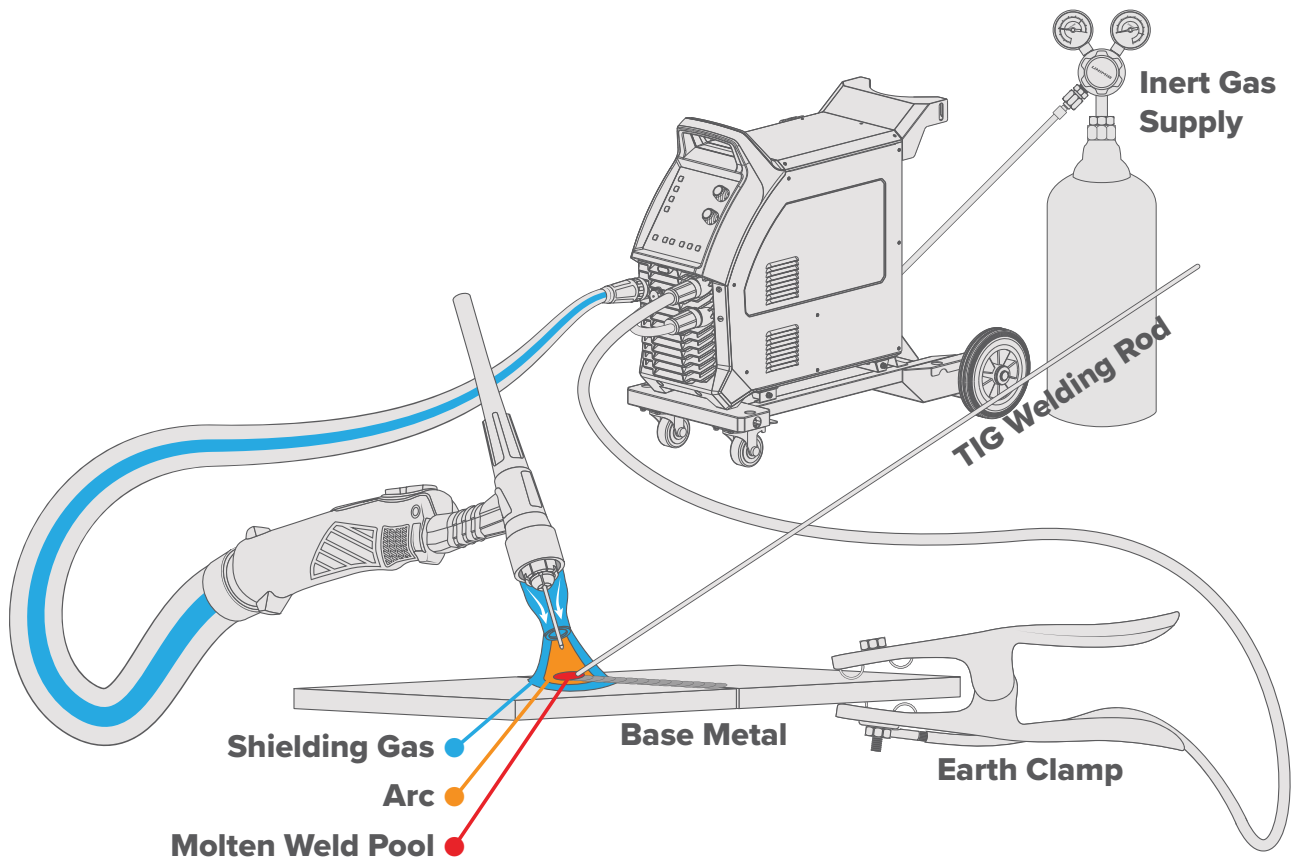

How TIG Welding Works

You can TIG weld two different ways: with alternating current (AC) or direct current (DC). Both need to be run on a constant-current power source to work. Both AC and DC TIG welding are done in negative polarity or Direct Current Electrode Negative (DCEN).

The current is negatively charged and runs from the positive to the negative. This means that 70% of the heat of the arc is concentrated in the workpiece.

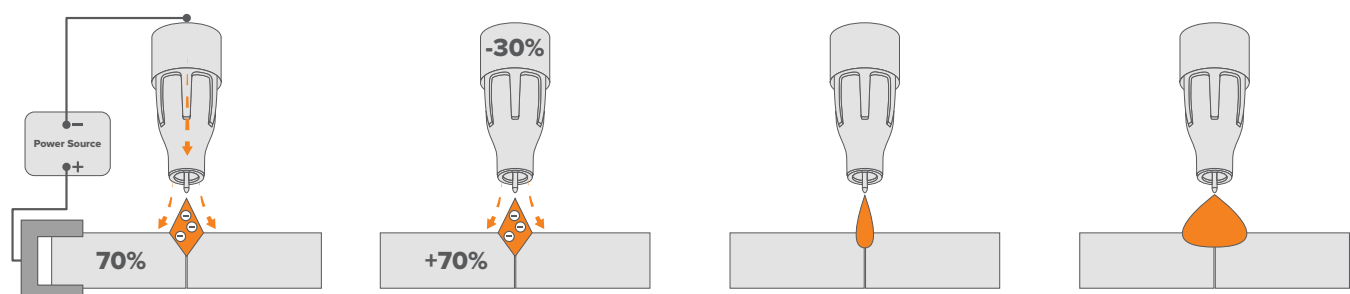

An arc is formed between the tungsten electrode and the workpiece. Tungsten has a melting point of 3,422°C, so it can withstand the heat of a welding arc. That's why it is a 'non-consumable' electrode. It doesn't melt and enter the weld pool. To add metal, an additional filler rod can be fed into the weld puddle by hand to form a proper weld.

TIG welding is the only welding process that requires the use of both hands to create the weld, so it is a completely manual process that has a steeper learning curve than MIG or MMA.

Lift Arc TIG Welding

Lift arc is a form of arc ignition which is done by touching the tungsten electrode to the workpiece and lifting it up to start the arc. When the machine detects that the tungsten has left the surface and a spark is present, it immediately (within microseconds) increases power, converting the spark to a full arc.

Lift arc ignition stops the tungsten tip from sticking to the workpiece and breaking the tungsten electrode, and is a superior option to scratch start.

There is a particular technique called "rocking the cup" used which is the easiest way to start an arc with lift arc.

Hold your torch at a 45° angle, with the gas shroud resting on the workpiece, without touching your tungsten to the metal. Then, in one motion, move the torch up to a 90° angle as the tungsten electrode touches the metal, and then lift it off the workpiece roughly 3mm to initiate the arc.

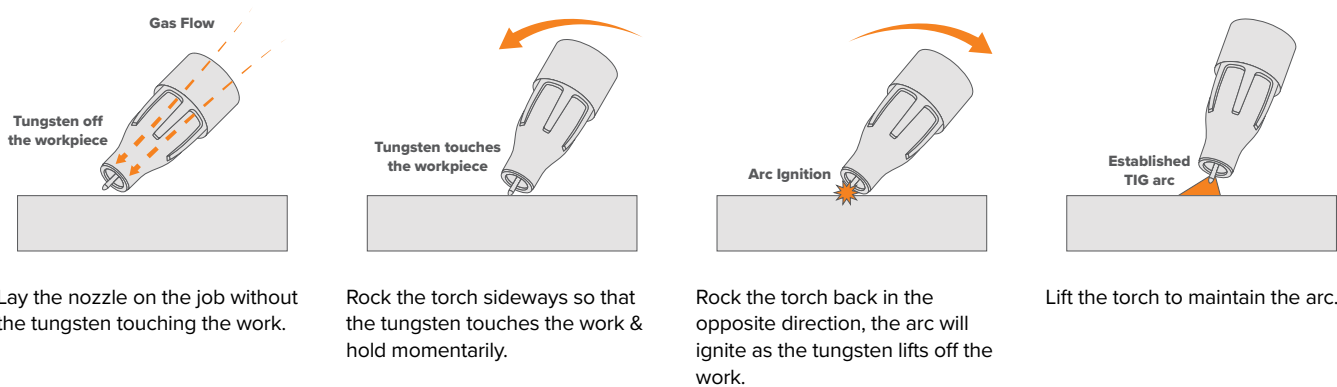

Pulse TIG

Pulse welding is a form of welding in which the amperage alternates between a high point and a low point. The high point is referred to as the peak amperage, and the low point is referred to as the base amperage. Pulse welding keeps the overall heat input of a weld low while still maintaining proper penetration.

There are four main variables when it comes to pulse welding: what the peak amperage is, what the base amperage is, how often it pulses, and how long it spends in either amperage setting.

Peak Amperage

The peak amperage is the main welding current set to melt the material being welded and works much the same as setting the maximum amperage values for regular TIG.

Base Amperage

The base amperage is the set level of background current which cools the weld puddle and effects the overall heat input. As a rule, you want enough background current to reduce the weld pool to about half its normal size while still keeping the weld pool fluid, or around 20%-30% of the peak amperage.

Pulse Frequency

The pulse frequency is the number of pulses per second. 1PPS equals one pulse per second, and 50PPS is 50 pulses per second.

If you're welding thin material, then a fast pulse is better, and it will produce a high profile bead. If you're welding thick material, then a slow pulse is better, and it will produce a low profile bead.

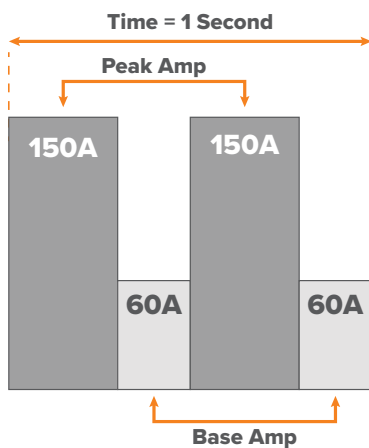

Pulse Width

The pulse percentage is the amount of time spent in the peak and base amperage for each pulse. If you set the percentage to 50%, that means 50% of the pulse cycle will be the peak amperage, and 50% of the pulse will be the base amperage.

You can adjust this either way, where 90% is almost entirely peak amperage and 20% is almost no peak amperage. The more time spent on the peak amperage part of the pulse, the more penetration you're going to get and vice versa.

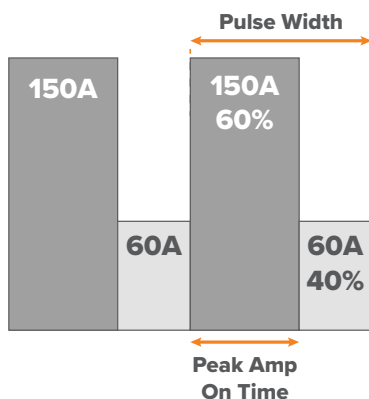

Filler Technique

When TIG welding, you'll almost always need to add filler for good reinforcement and a strong weld. Start the arc and hold the torch in place until a weld pool of the desired size has formed. Once the weld pool is established, tilt the torch at about a 75° angle and move along the joint.

The filler rod is usually held at about a 15° angle and fed into the leading edge of the molten pool. The arc will melt the filler rod into the weld pool as the torch is moved forward. A dabbing technique can be used to control the amount of filler rod that's added. A good rule of thumb is to add the same amount on each dab as the rod's width.

The rod is fed into the molten pool and retracted in a repeating sequence as the torch is moved slowly and evenly forward. It is essential during the welding to keep the molten end of the filler wire inside the gas shield as this protects the end of the wire from being oxidised and contaminating the weld pool.

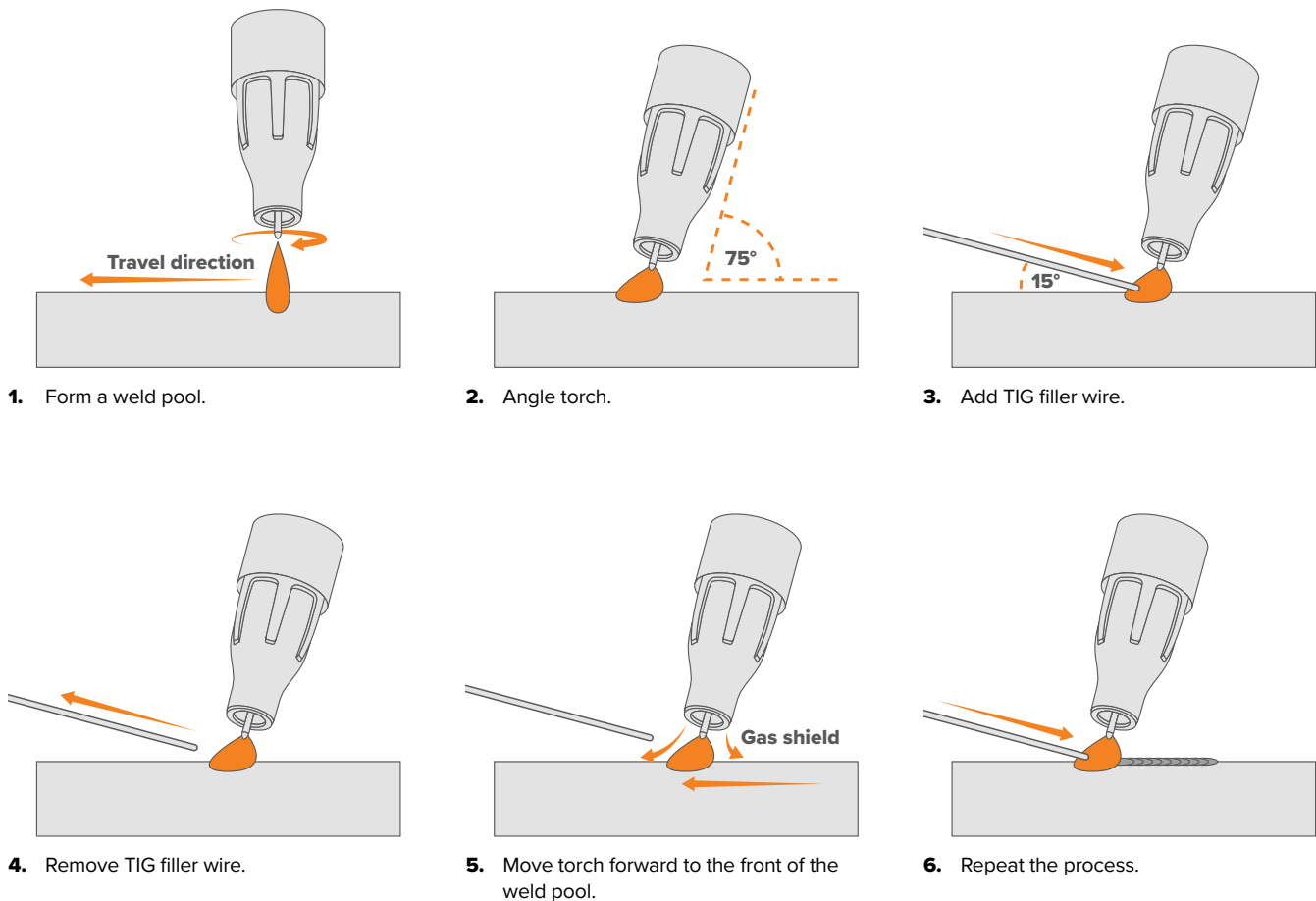

Fusion Technique

While filler material is required a majority of the time, there are some instances when TIG welding where it isn't needed. This is known as fusion, or autogenous, welding. The edges of the metal pieces are melted together using only the heat and arc force generated by the TIG arc.

Fusion welding is done the exact same way as TIG welding with filler, minus the filler rod. Start the arc and hold the torch in place until a weld pool of the desired size has formed. Once the weld pool is established, tilt the torch at about a 75° angle and move slowly and evenly along the joint, fusing the materials together.

Fusion welding is primarily used when combining thin materials on edge, corner, and butt joints.

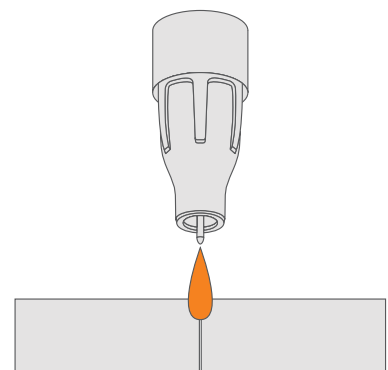

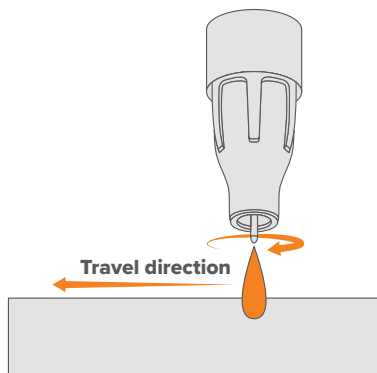

1. Form a weld pool.

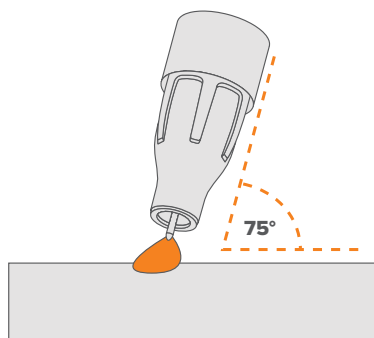



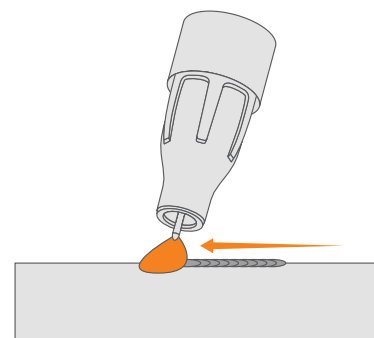

2. Angle torch.



3. Move the torch slowly and evenly forward.

Tungsten Selection

	 LANTHANATED (GOLD)	 ZIRCONIATED (WHITE)	 THORIATED (RED)	 RARE EARTH (PURPLE)	 CERATED (GREY)
AC CURRENT	✓	✓		✓	✓
DC CURRENT	✓		✓	✓	✓
ALUMINIUM	✓	✓		✓	✓
MILD STEEL	✓		✓	✓	✓
STAINLESS STEEL	✓		✓	✓	✓
TITANIUM / COPPER ALLOYS	✓		✓	✓	✓
ARC IGNITION	●●●●●	●●●●●	●●●●●	●●●●●	●●●●●
TUNGSTEN LIFE	●●●●●	●●●●●	●●●●●	●●●●●	●●●●●
ARC STABILITY	●●●●●	●●●●●	●●●●●	●●●●●	●●●●●
RESISTANCE TO CONTAMINATION	●●●●●	●●●●●	●●●●●	●●●●●	●●●●●
AC PERFORMANCE	●●●●●	●●●●●	N/A	●●●●●	●●●●●

This information is intended to act as a guide only, individual results may vary depending on technique, skill and material.

Tungsten Preparation

There are a few different ways to prepare your tungsten, and different shapes will give different results on different applications.

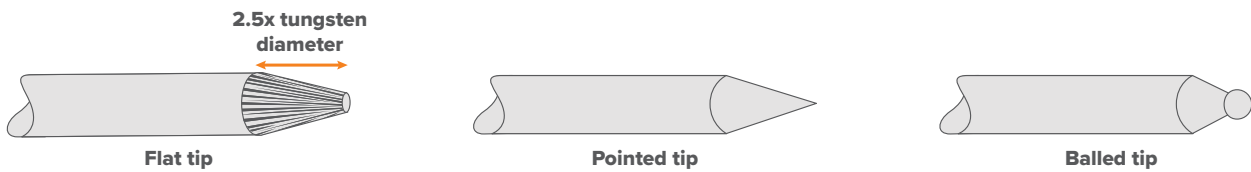

The most common tungsten shape to weld stainless and mild steel with is pointed, which produces a focused and stable arc, and works for all DC applications. To get this pointed shape, you'll need a tungsten grinder or a bench grinder (a diamond wheel is best).

If you use a bench grinder, it needs to be dedicated to tungsten preparation, as you can contaminate your tungsten with anything that's leftover on the grinder.

Press your tungsten vertically to the grinder at a 30° angle and rotate at a consistent pace until a point has formed. It's essential to grind with the tungsten's grain (lengthwise) and not against it (horizontal on the grinder) for a few reasons.

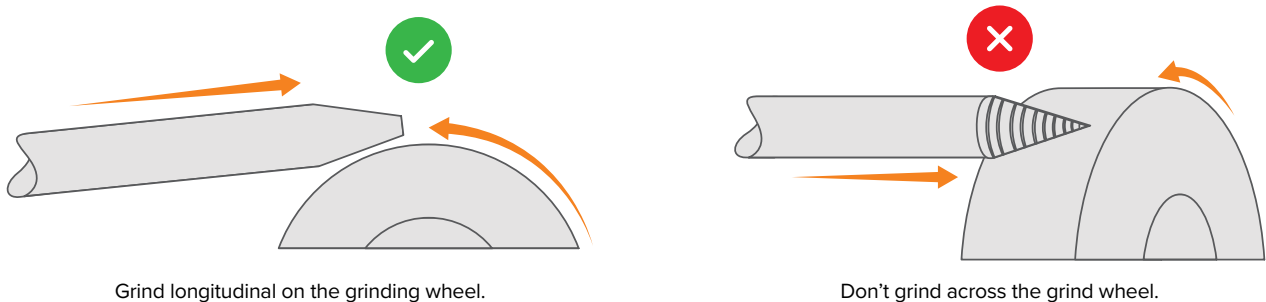

The main reason is that it lowers the number of ridges in the tip of the tungsten. More ridges mean that the arc has more surface to cover, increasing your chances of it wandering or the tip melting off and falling into your weld pool. Your tungsten will also stay sharper for longer if you follow the grain, so you won't need to re-grind it as often.

A truncated/flat tip follows the same preparation as a pointed tip but with the added step of grinding the end, so you get a flat top. This shape works well for both AC and DC applications.

Gas Coverage Check

To ensure you have adequate gas coverage, first form a weld pool on a test piece of metal, then release the trigger and allow for 8-10 seconds of post-flow. If the gas coverage is sufficient, the weld pool will appear shiny and clear. Conversely, if the gas coverage is poor, the weld pool will look dark and sooty.

To address gas coverage issues, make sure the post-flow timing is accurate and adjust the flow rate according to the type of gas and the thickness of the material (see *"Recommended Gas Flow Rates"* on page 51).

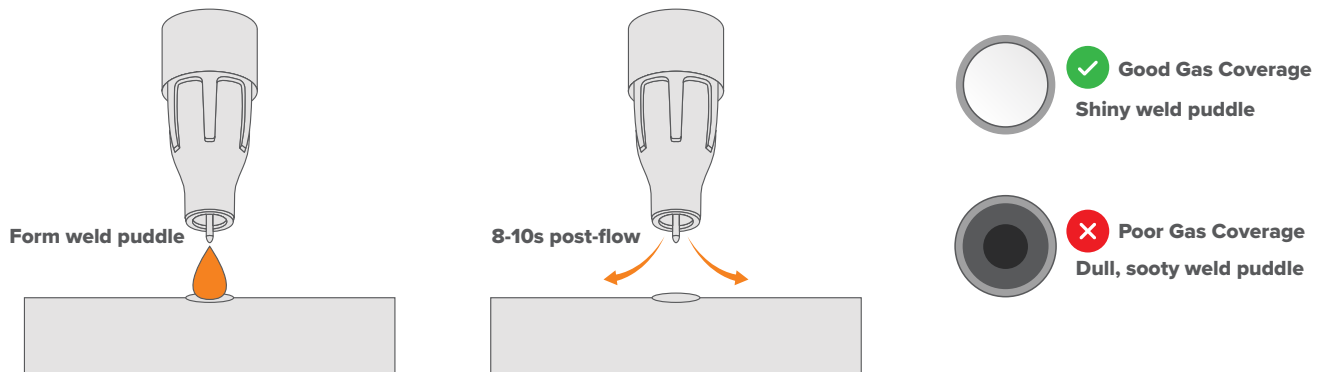

13. MMA Welding Guide

What is MMA Welding?

Manual Metal Arc (MMA) welding is an arc welding process in which an arc is formed between a flux-covered electrode and the base metal. The arc melts the electrode into the workpiece, forming the weld.

MMA is also referred to as Shielded Metal Arc Welding (SMAW), but it's most commonly known as 'stick' welding.

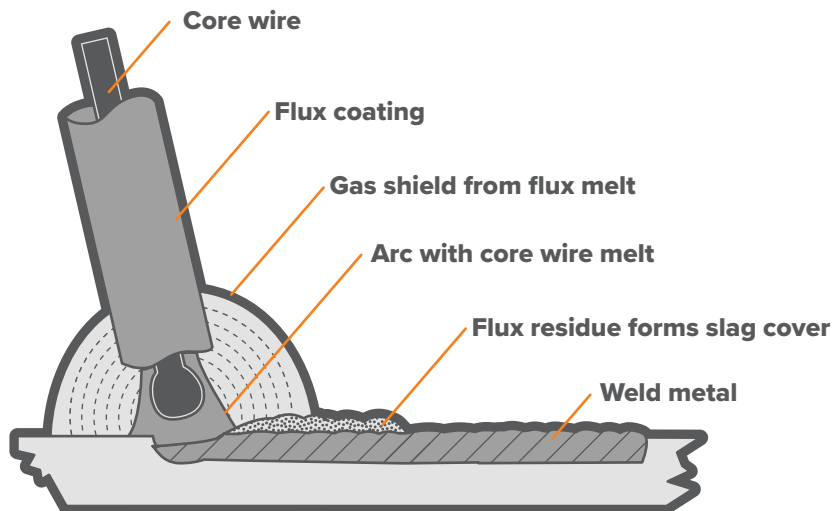

How MMA Welding Works

You can MMA weld two different ways: with alternating current (AC) or direct current (DC). Both need to be run on a constant-current power source to work. The electrode is tapped or struck against the base metal, which ignites the arc between the two. The electrodes used in MMA welding are consumable electrodes, as they melt into the base metal to form the weld.

An external gas isn't needed as the outer flux coating on each electrode works to shield the weld as it melts. The flux coating melts with the metal, releasing gases from within which bubble to the surface.

These internal gases protect the weld from outside contaminants until the puddle begins to cool. The flux coating, once melted, forms a layer of slag over the final weld, which needs to be chipped off to achieve a clean, finished weld.

Electrode Selection

There is a range of different electrodes available for MMA welding. Each is stamped with its own classification code, which details the properties of each electrode. For mild steel electrodes, there is an 'E' followed by a 4-digit code, for example, E6013.



You'll need to select an electrode with a similar composition to the base metal. Generally speaking, the most common electrodes used for mild steel are E6010, E6011, E6013, E7016, E7018 and E7024. Stainless steel electrodes are marked with their metal grade, e.g., 309L.

The size of the electrode generally depends on the thickness of the section being welded, and the thicker the section,

the larger the electrode required. The table gives the maximum size of electrodes that may be used for various thicknesses of section based on using a general-purpose type 6013 electrode.

Average Thickness of Material	Maximum Recommended Electrode Diameter
3-6mm	2.6mm
6-12mm	3.2mm
12-20mm	4.0mm
20mm+	5.0mm

The amperage you'll need is dependent on the electrode size and base metal thickness.

With the amperage set too low, it's difficult to strike and maintain a stable arc. The penetration is reduced and beads with a distinct rounded profile will be deposited. Too high an amperage is accompanied by overheating of the electrode, resulting in undercut, burning through of the base metal and producing excessive spatter.

Electrodes will usually come with a recommended amperage rating. The table shows current ranges generally recommended for a general-purpose type 6013 electrode.

Electrode Size	Current Range
3-6mm	60-100A
6-12mm	100-130A
12-20mm	130-165A
20mm+	165-260A

Work Angle

The work angle is the up and down of the electrode in relation to the angle of the joint. There are a few different joint types, and several positions these joints can be found.

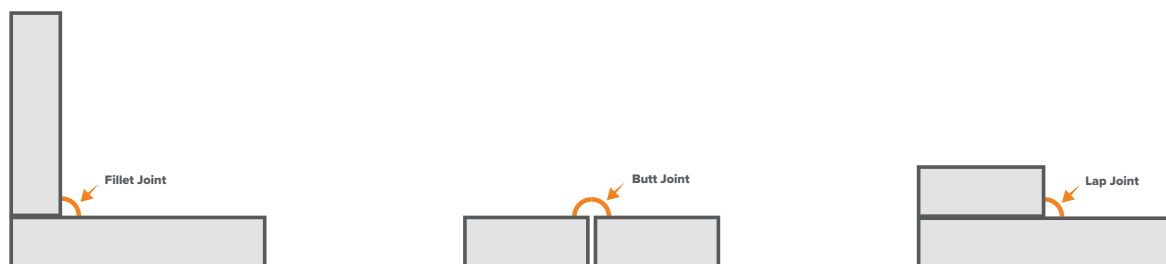

Fillet Joint (T-Joint)	Butt Joint	Lap Joint
90° joint angle	180° joint angle	90° joint angle
45° work angle	90° work angle	60-70° work angle

Travel Direction & Angle

When MMA welding, you only want to drag (pull) your weld. If you use a push angle, you risk having slag trapped in the weld pool and contaminating the weld. To drag your weld, place your electrode into the joint then tilt it slightly sideways by 10° to 15° . Your torch should hover over where you're going to be welding, rather than hovering over where you've already welded. When welding vertical up, the electrode should sit in the joint at roughly an 80° angle.

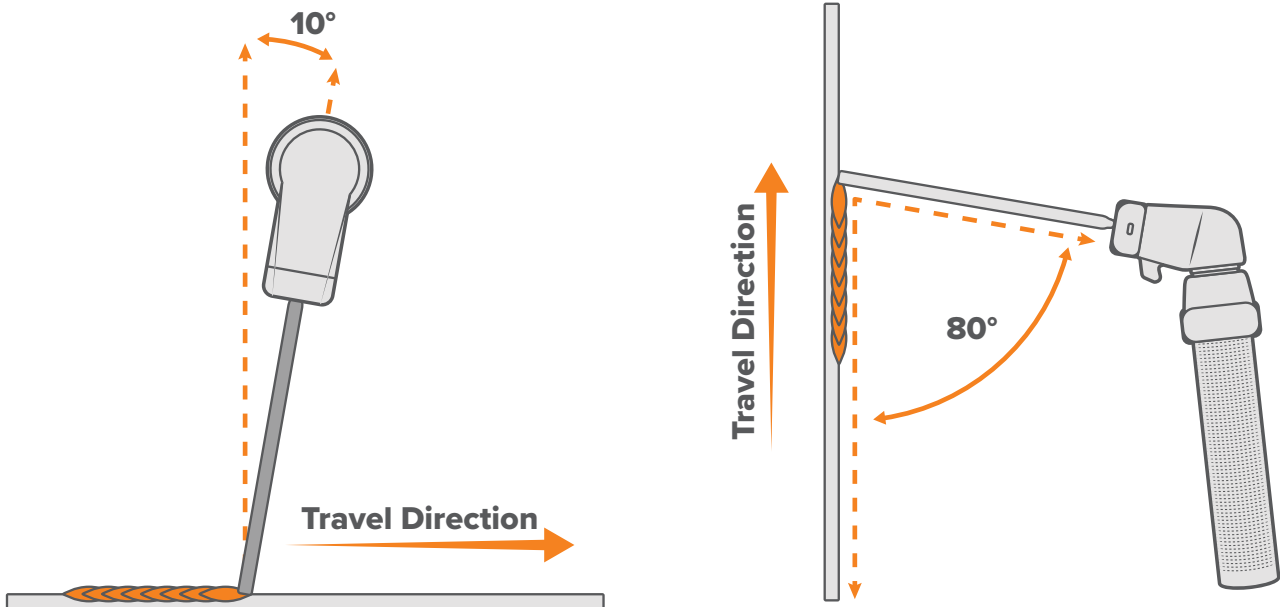

Arc Length

To strike the arc, the electrode should be gently scraped on the work until the arc is established. When welding, keep the arc length short. A good rule of thumb is that your arc length shouldn't be longer than your electrode diameter.

An arc too long reduces penetration, produces spatter and gives a rough surface finish to the weld. An excessively short arc will cause sticking of the electrode and result in poor quality welds.

Travel Speed

The electrode should be moved along in the direction of the joint being welded at a speed that will give the size of run required. At the same time, the electrode is fed downwards to keep the correct arc length at all times.

Travelling too fast will lead to poor fusion and a lack of penetration, while travelling too slow will frequently lead to arc instability, slag inclusions and burnthrough.

14. Gas Selection

14.1 MIG

Gas	Material Thickness (mm)															Thickness Range per Rod Diameter			
	1	2	3	4	5	6	7	8	9	10	11	12	13	14	15+	1.6mm	2.4mm	3.2mm	4.0mm
Ar 100%	Orange	Orange	Orange	Orange	Orange	Orange	Orange	Orange	Orange	Orange	Orange	Orange	White	White	White	Up to 5mm	2-12mm	4-12mm	5-12mm
Ar + 10-30% He	White	Orange	Orange	Orange	Orange	Orange	Orange	Orange	Orange	Orange	Orange	Orange	Orange	Orange	White	2-6mm	3-13mm	5-14mm	6mm+
Ar + 50-75% He	White	White	Orange	Orange	Orange	Orange	Orange	Orange	Orange	Orange	Orange	Orange	Orange	Orange	White	3-7mm	4-14mm	5-15mm	7mm+

14.2 TIG

Gas	Material Thickness (mm)															Thickness Range per Rod Diameter			
	1	2	3	4	5	6	7	8	9	10	11	12	13	14	15+	1.6mm	2.4mm	3.2mm	4.0mm
Ar 100%	Orange	Orange	Orange	Orange	Orange	Orange	Orange	Orange	Orange	Orange	Orange	Orange	White	White	White	Up to 5mm	2-12mm	4-12mm	5-12mm
Ar + 10-30% He	White	Orange	Orange	Orange	Orange	Orange	Orange	Orange	Orange	Orange	Orange	Orange	Orange	Orange	White	2-6mm	3-13mm	5-14mm	6mm+
Ar + 50-75% He	White	White	Orange	Orange	Orange	Orange	Orange	Orange	Orange	Orange	Orange	Orange	Orange	Orange	White	3-7mm	4-14mm	5-15mm	7mm+

i This setup information is intended to act as a guide only. Individual results may vary depending on technique, skill and material.

15. Welding Processes & Features Glossary

A

Anti-Stick - Anti-stick limits the maximum current output to prevent the stick electrode from fusing to the workpiece, ensuring smoother operation and reducing electrode wastage.

Arc Force - The level of current boost when the machine senses voltage drops, improving arc stability and preventing electrode sticking. A higher value gives a more forceful arc, especially useful in vertical or overhead positions.

B

Burn Back - Burn Back determines how long the wire will stay charged after feeding stops. It ensures the wire end is clean for the next start and reduces the risk of wire sticking to the workpiece.

G

Gas Test - The Gas Test allows you to test and set the shielding gas flow rate. It also lets you back purge pipes and tubing being welded.

I

Inductance - The inductance controls the arc's smoothness and spatter. A higher inductance gives a softer arc with less spatter. A lower inductance makes the arc more focused and offers better penetration.

L

Lift TIG - Lift Arc TIG is an arc ignition mode that initiates the arc by making brief contact between the tungsten and the workpiece. Once lifted, the arc continues without touching.

M

MMA - Manual Metal Arc (MMA) welding is an arc welding process in which an arc is formed between a flux-covered electrode and the base metal. The flux covering acts as a protective layer for the weld.

P

Pregas Timer - The duration of shielding gas released before the arc ignites. This ensures a protective environment, minimising contamination and improving weld quality.

Postgas Timer - The duration of shielding gas released after the welding arc stops. This provides continued protection to the welded area, preventing oxidation and ensuring a cleaner weld finish.

S

Spot Mode - Spot Mode provides precision in creating timed weld spots with controlled intervals and counts. It's ideal for consistent tacking or producing uniform joins across materials.

Spot Timer - The time between each spot weld.

T

Trigger Mode 2T - Initiates welding when the torch trigger is pressed and stops when released.

Trigger Mode 4T - Press the torch trigger once to start welding and release it. Press again to stop the weld. This mode is useful for longer welds and reducing hand fatigue.

Trigger Mode S4T - Adjust the welding current while welding with Special 4T torch mode. Press the torch trigger to start welding at the Start Amp value. Release it to increase to the Peak Amp value. Press and hold the torch trigger to decrease to the End Amp value. Release it to increase back to the Peak Amp value. Double press the torch trigger to end the weld. This mode allows for more manual heat input control.

V

VRD - A Voltage Reduction Device is a safety device that reduces the open-circuit voltage of a welding machine. This minimises the risk of electric shock, especially in hazardous areas like enclosed or moist environments.

16. MIG Torch & Consumables

16.1 M350 MIG Torch

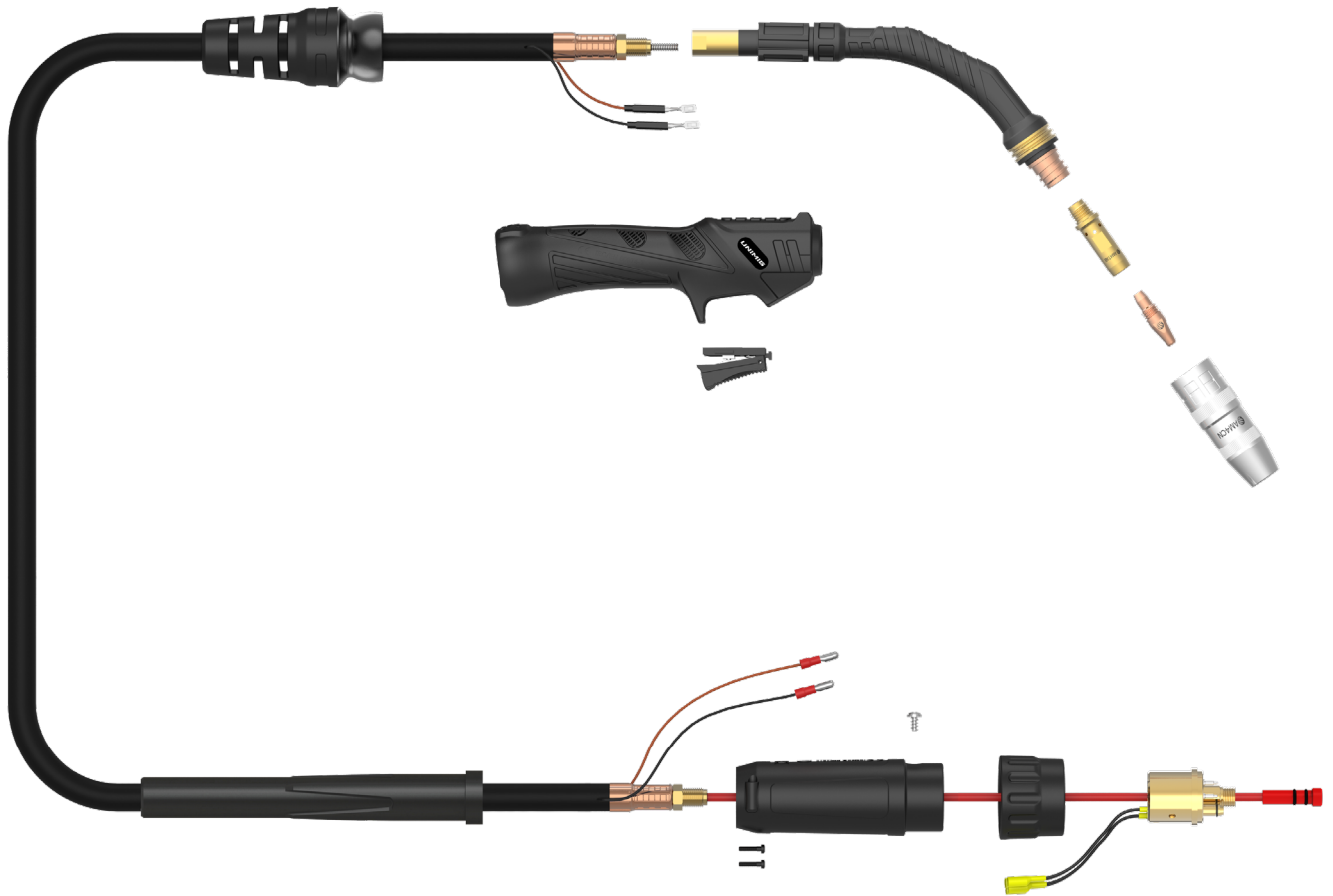

Length	3m	4m
SKU	U11071	U11072

COOLING METHOD	Air-Cooled
DUTY CYCLE - CO2	60% @ 350A
DUTY CYCLE - MIXED GAS	60% @ 320A
LENGTHS (m)	3, 4
WIRE SIZE	0.8-1.2mm
STANDARD	EN60974-7

16.2 M350 MIG Torch Consumables



Tip Adapter

U11060	TIP ADAPTER SUIT M350 QTY 2
---------------	-----------------------------



Contact Tips

U11171	CONTACT TIP STEEL 0.8MM SUIT M350/M580W QTY 10
U11045	CONTACT TIP STEEL 0.9MM SUIT M350/M580W QTY 10
U11046	CONTACT TIP STEEL 1.0MM SUIT M350/M580W QTY 10
U11047	CONTACT TIP STEEL 1.2MM SUIT M350/M580W QTY 10
U11050	CONTACT TIP ALUMINIUM 1.0MM SUIT M350/M580W QTY 10
U11051	CONTACT TIP ALUMINIUM 1.2MM SUIT M350/M580W QTY 10



Gas Nozzle

U11055	GAS NOZZLE WITH INSULATOR CONICAL SUIT M350 QTY 2
U11056	GAS NOZZLE WITH INSULATOR CYLINDRICAL SUIT M350 QTY 2
U11054	GAS NOZZLE WITH INSULATOR TAPERED SUIT M350 QTY 2



Liners

U11065	LINER COMBINATION 0.8-1.2MM 3M SUIT M350 QTY 1
U11066	LINER COMBINATION 0.8-1.2MM 4M SUIT M350 QTY 1
U11178	LINER STEEL 0.6-0.9MM 3M SUIT M350 QTY 1
U11179	LINER STEEL 0.6-0.9MM 4M SUIT M350 QTY 1
U11180	LINER STEEL 1.0-1.2MM 3M SUIT M350 QTY 1
U11181	LINER STEEL 1.0-1.2MM 4M SUIT M350 QTY 1

16.3 M580W MIG Torch

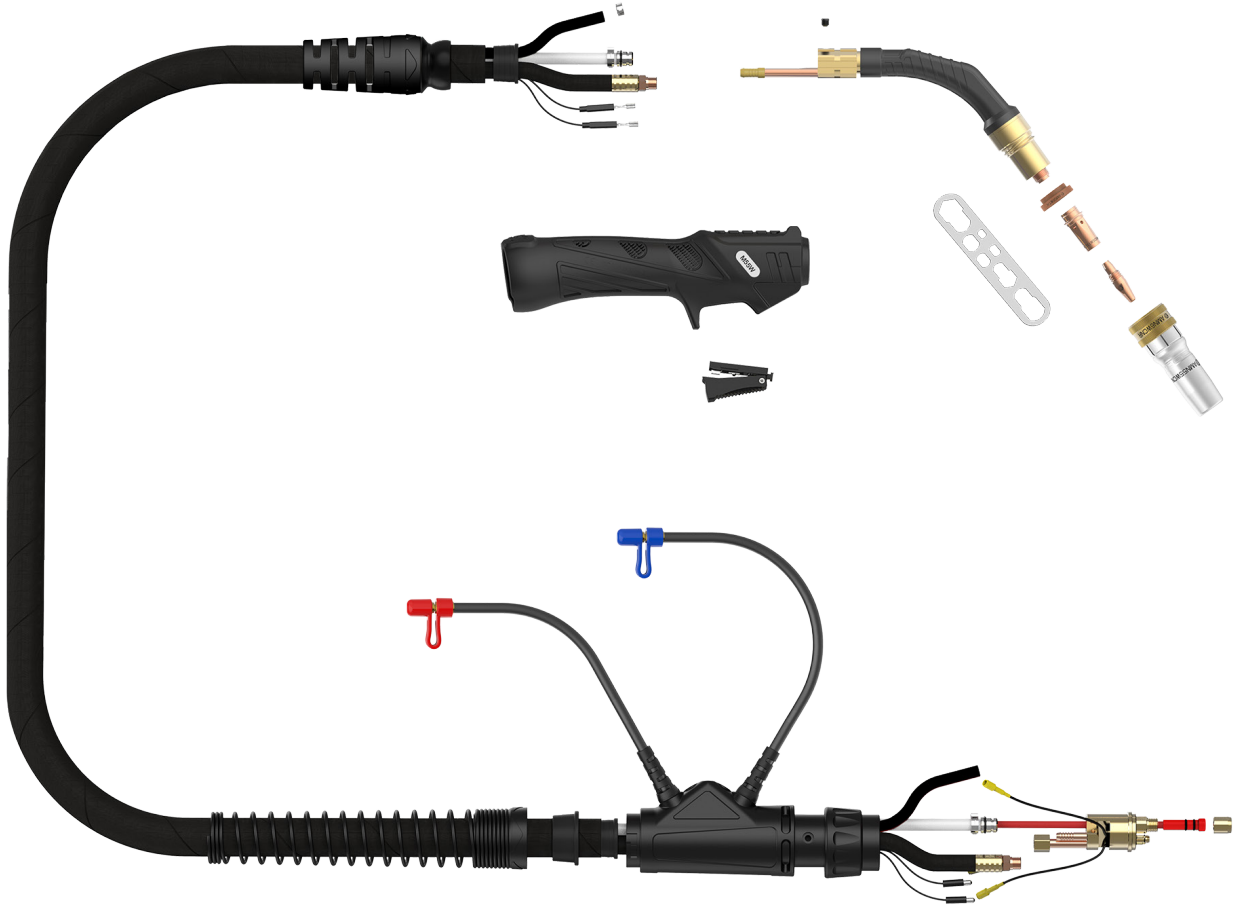

Length	3m	4m
SKU	U11073	U11074

COOLING METHOD	Water-Cooled
DUTY CYCLE - CO2	100% @ 580A
DUTY CYCLE - MIXED GAS	100% @ 560A
DUTY CYCLE - PULSE	100% @ 400A
LENGTHS (m)	3, 4
WIRE SIZE	0.8-1.6mm
STANDARD	EN60974-7

16.4 M580W MIG Torch Consumables



Tip Adapter Insulator

U11064	TIP ADAPTER INSULATOR SUIT M580W QTY 2
---------------	--

Tip Adapter

U11063	TIP ADAPTER SUIT M580W QTY 2
---------------	------------------------------

Contact Tips

U11171	CONTACT TIP STEEL 0.8MM SUIT M350/M580W QTY 10
U11045	CONTACT TIP STEEL 0.9MM SUIT M350/M580W QTY 10
U11046	CONTACT TIP STEEL 1.0MM SUIT M350/M580W QTY 10
U11047	CONTACT TIP STEEL 1.2MM SUIT M350/M580W QTY 10
U11048	CONTACT TIP STEEL 1.6MM SUIT M350/M580W QTY 10
U11050	CONTACT TIP ALUMINIUM 1.0MM SUIT M350/M580W QTY 10
U11051	CONTACT TIP ALUMINIUM 1.2MM SUIT M350/M580W QTY 10
U11052	CONTACT TIP ALUMINIUM 1.6MM SUIT M350/M580W QTY 10

Gas Nozzle

U11057	GAS NOZZLE WITH INSULATOR CONICAL SUIT M580W QTY 2
U11058	GAS NOZZLE WITH INSULATOR TAPERED SUIT M580W QTY 2
U11059	GAS NOZZLE WITH INSULATOR CYLINDRICAL SUIT M580W QTY 2

Liners

U11067	LINER COMBINATION 1.0-1.2MM 3M SUIT M580W QTY 1
U11068	LINER COMBINATION 1.0-1.2MM 4M SUIT M580W QTY 1
U11069	LINER COMBINATION 1.6-2.0MM 3M SUIT M580W QTY 1
U11070	LINER COMBINATION 1.6-2.0MM 4M SUIT M580W QTY 1
U11174	LINER STEEL 0.8-1.2MM 3M SUIT M580W QTY 1
U11175	LINER STEEL 0.8-1.2MM 4M SUIT M580W QTY 1

17. Recommended Accessories



M350 MIG Starter Kit
U11075



M580W MIG Starter Kit
U11076



220A Spool Gun
U41014



300A Digital Push-Pull Gun
U11220



400A Digital Water-Cooled Push-Pull Gun
U11221

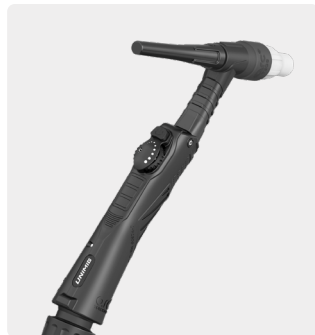

T2 TIG Torch
UMT24ME

Drive Rollers



U11489	DRIVE ROLLER 37/24 U ALUMINIUM 0.8/0.9MM
U11493	DRIVE ROLLER 37/24 U ALUMINIUM 0.9/1.0MM
U11492	DRIVE ROLLER 37/24 U ALUMINIUM 0.9/1.2MM
U11490	DRIVE ROLLER 37/24 U ALUMINIUM 1.0/1.2MM
U11491	DRIVE ROLLER 37/24 U ALUMINIUM 1.2/1.6MM
U11485	DRIVE ROLLER 37/24 F KNURLED 0.8/0.9MM
U11488	DRIVE ROLLER 37/24 F KNURLED 0.9/1.2MM
U11486	DRIVE ROLLER 37/24 F KNURLED 1.0/1.2MM
U11487	DRIVE ROLLER 37/24 F KNURLED 1.2/1.6MM
U11479	DRIVE ROLLER 37/24 V STEEL 0.6/0.8MM
U11483	DRIVE ROLLER 37/24 V STEEL 0.8/0.9MM
U11480	DRIVE ROLLER 37/24 V STEEL 0.8/1.0MM
U11484	DRIVE ROLLER 37/24 V STEEL 0.9/1.2MM
U11481	DRIVE ROLLER 37/24 V STEEL 1.0/1.2MM
U11482	DRIVE ROLLER 37/24 V STEEL 1.2/1.6MM

MIG Wire



U61001	HYPERCORE T-11 FLUX-CORED SELF-SHIELDED WIRE 0.8MM 4.54KG
U61002	HYPERCORE T-11 FLUX-CORED SELF-SHIELDED WIRE 0.9MM 4.54KG
U11162	HYPERMIG 5356 ALUMINIUM PREMIUM 1.0MM 7KG
U11163	HYPERMIG 5356 ALUMINIUM PREMIUM 1.2MM 7KG
U61014	HYPERCORE T-11 FLUX-CORED SELF-SHIELDED WIRE 1.2MM 4.54KG
MS.6B	ER70S-6 MILD STEEL WIRE 0.6MM 5KG
MS.8B	ER70S-6 MILD STEEL WIRE 0.8MM 5KG
MS.9B	ER70S-6 MILD STEEL WIRE 0.9MM 5KG
MS.6C	HYPERMIG ER70S-6 MILD STEEL 0.6MM 15KG
MS.8C	HYPERMIG ER70S-6 MILD STEEL 0.8MM 15KG
MS.9C	HYPERMIG ER70S-6 MILD STEEL 0.9MM 15KG
MS.12C	HYPERMIG ER70S-6 MILD STEEL 1.2MM 15KG
SS316LSI-0.8-5	316L STAINLESS STEEL WIRE 0.8MM 5KG
SS316LSI-0.9-5	316L STAINLESS STEEL WIRE 0.9MM 5KG
SS308LSI-0.9	HYPERMIG 308LSI STAINLESS STEEL 0.9MM 12.5KG
SS308LSI-1.2	HYPERMIG 308LSI STAINLESS STEEL 1.2MM 12.5KG
SS309LSI-0.9	HYPERMIG 309LSI STAINLESS STEEL 0.9MM 12.5KG
SS309LSI-1.2	HYPERMIG 309LSI STAINLESS STEEL 1.2MM 12.5KG
SS316LSI-0.9	HYPERMIG 316LSI STAINLESS STEEL 0.9MM 12.5KG
SS316LSI-1.2	HYPERMIG 316LSI STAINLESS STEEL 1.2MM 12.5KG

TIG Tungsten Electrodes



PTR0003-10	CERIATED TUNGSTEN GREY 1.0MM QTY 10
PTR0003-16	CERIATED TUNGSTEN GREY 1.6MM QTY 10
PTR0003-24	CERIATED TUNGSTEN GREY 2.4MM QTY 10
PTR0003-32	CERIATED TUNGSTEN GREY 3.2MM QTY 10
PTR0002-16	LANTHANATED TUNGSTEN GOLD 1.6MM QTY 10
PTR0002-24	LANTHANATED TUNGSTEN GOLD 2.4MM QTY 10
PTR0002-32	LANTHANATED TUNGSTEN GOLD 3.2MM QTY 10
PTR0005-16	RARE EARTH TUNGSTEN PURPLE 1.6MM QTY 10
PTR0005-24	RARE EARTH TUNGSTEN PURPLE 2.4MM QTY 10
PTR0005-32	RARE EARTH TUNGSTEN PURPLE 3.2MM QTY 10
PTR0004-10	THORIATED TUNGSTEN RED 1.0MM QTY 10
PTR0004-16	THORIATED TUNGSTEN RED 1.6MM QTY 10
PTR0004-24	THORIATED TUNGSTEN RED 2.4MM QTY 10
PTR0004-32	THORIATED TUNGSTEN RED 3.2MM QTY 10

TIG Welding Rods



TG102ER70S-2-1.6	ER70S-2-TIG FILLER ROD 1.6MM 5KG TRIPLE DEOXIDISED
TG102ER70S-2-2.4	ER70S-2-TIG FILLER ROD 2.4MM 5KG TRIPLE DEOXIDISED
TG4ER70S-4-1.6	ER70S-4-TIG FILLER ROD 1.6MM 5KG DOUBLE DEOXIDISED
TG4ER70S-4-2.4	ER70S-4-TIG FILLER ROD 2.4MM 5KG DOUBLE DEOXIDISED
TG2ER70S-6-1.6	ER70S-6-TIG FILLER ROD 1.6MM 5KG
TG2ER70S-6-2.4	ER70S-6-TIG FILLER ROD 2.4MM 5KG
TI308L-1.6	308L TIG FILLER ROD 1.6MM 5KG
TI308L-2.4	308L TIG FILLER ROD 2.4MM 5KG
TI309L-1.6	309L TIG FILLER ROD 1.6MM 5KG
TI309L-2.4	309L TIG FILLER ROD 2.4MM 5KG
TI316L-1.2	316L TIG FILLER ROD 1.2MM 5KG
TI316L-1.6-1	316L TIG FILLER ROD 1.6MM 1KG
TI316L-1.6	316L TIG FILLER ROD 1.6MM 5KG
TI316L-2.4-1	316L TIG FILLER ROD 2.4MM 1KG
TI316L-2.4	316L TIG FILLER ROD 2.4MM 5KG
TI316L-3.2	316L TIG FILLER ROD 3.2MM 5KG

MMA Welding Electrodes



U63028	HYPERARC NI 55 CAST IRON ELECTRODES 2.6MM 1KG
U63029	HYPERARC NI 55 CAST IRON ELECTRODES 3.2MM 1KG
U63026	HYPERARC NI 98 CAST IRON ELECTRODES 2.6MM 1KG
U63027	HYPERARC NI 98 CAST IRON ELECTRODES 3.2MM 1KG
U63025	HYPERARC 531 HARDFACING ELECTRODES 3.2MM 1KG
U63014	HYPERARC 309L STAINLESS STEEL ELECTRODES 2.6MM 2KG
U63015	HYPERARC 309L STAINLESS STEEL ELECTRODES 3.2MM 2KG
U63017	HYPERARC 312L STAINLESS STEEL ELECTRODES 2.6MM 1KG
U63019	HYPERARC 312L STAINLESS STEEL ELECTRODES 2.6MM 2KG
U63018	HYPERARC 312L STAINLESS STEEL ELECTRODES 3.2MM 1KG
U63020	HYPERARC 312L STAINLESS STEEL ELECTRODES 3.2MM 2KG
U63021	HYPERARC 316L STAINLESS STEEL ELECTRODES 2.6MM 1KG
U63023	HYPERARC 316L STAINLESS STEEL ELECTRODES 2.6MM 2KG
U63022	HYPERARC 316L STAINLESS STEEL ELECTRODES 3.2MM 1KG
U63024	HYPERARC 316L STAINLESS STEEL ELECTRODES 3.2MM 2KG
U63006	HYPERARC 16 TWIN COAT LOW-HYDROGEN ELECTRODES 2.6MM 1KG
U63008	HYPERARC 16 TWIN COAT LOW-HYDROGEN ELECTRODES 2.6MM 2KG
U63007	HYPERARC 16 TWIN COAT LOW-HYDROGEN ELECTRODES 3.2MM 1KG
U63009	HYPERARC 16 TWIN COAT LOW-HYDROGEN ELECTRODES 3.2MM 2KG
U63010	HYPERARC 16 TWIN COAT LOW-HYDROGEN ELECTRODES 4.0MM 2KG
U63002	HYPERARC 6013 GENERAL PURPOSE ELECTRODES 3.2MM 1KG
U63030	HYPERARC 6013 GENERAL PURPOSE ELECTRODES 2.0MM 1KG
U63031	HYPERARC 6013 GENERAL PURPOSE ELECTRODES 2.0MM 2.5KG
U63001	HYPERARC 6013 GENERAL PURPOSE ELECTRODES 2.6MM 1KG
U63032	HYPERARC 6013 GENERAL PURPOSE ELECTRODES 2.6MM 2.5KG
U63003	HYPERARC 6013 GENERAL PURPOSE ELECTRODES 2.6MM 5KG
U63033	HYPERARC 6013 GENERAL PURPOSE ELECTRODES 3.2MM 2.5KG
U63004	HYPERARC 6013 GENERAL PURPOSE ELECTRODES 3.2MM 5KG
U63005	HYPERARC 6013 GENERAL PURPOSE ELECTRODES 4.0MM 5KG
U63011	HYPERARC 7018 LOW-HYDROGEN ELECTRODES 2.6MM 2KG
U63012	HYPERARC 7018 LOW-HYDROGEN ELECTRODES 3.2MM 2KG
U63013	HYPERARC 7018 LOW-HYDROGEN ELECTRODES 4.0MM 2KG

A series of horizontal dotted lines for writing, spanning the width of the page.

UNIMIG

B U I L T F O R W E L D E R S



100%
AUSTRALIAN
OWNED

unimig.com.au

    @UNIMIG