

**1 YEAR**  
PRODUCT  
WARRANTY



# UNIMIG® VIPER CUT 30

KUMJRV30 | Operating Manual





# CONTENTS

SAFETY.....	4
TECHNICAL DATA.....	7
MACHINE LAYOUT.....	8
WHAT'S IN THE BOX.....	9
SETUP FOR PLASMA CUTTING.....	10
PLASMA CUTTING PARAMETER GUIDE.....	12
PLASMA CUTTING TECHNOLOGY.....	13
PLASMA CUTTING TIPS & TECHNIQUES.....	14
TORCH BREAKDOWN & SPARES.....	16
FAQ & TROUBLESHOOTING.....	17

**Welding and cutting equipment can be dangerous to both the operator and people in or near the surrounding working area if the equipment is not correctly operated. Equipment must only be used under the strict and comprehensive observance of all relevant safety regulations.**

**Read and understand this instruction manual carefully before the installation and operation of this equipment.**

## **WARNING: USE COMPRESSED AIR ONLY WITH THIS MACHINE**

### **Machine Operating Safety**

- Do not switch the function modes while the machine is operating. Switching of the function modes during welding can damage the machine. Damage caused in this manner will not be covered under warranty.
- Disconnect the electrode-holder cable from the machine before switching on the machine, to avoid arcing should the electrode be in contact with the workpiece.
- Operators should be trained and or qualified.



**Electric shock: It can kill.** Touching live electrical parts can cause fatal shocks or severe burns. The electrode and work circuit is electrically live whenever the output is on. The input power circuit and internal machine circuits are also live when power is on. In MIG/MAG welding, the wire, drive rollers, wire feed housing, and all metal parts touching the welding wire are electrically live. Incorrectly installed or improperly grounded equipment is dangerous.

- Connect the primary input cable, according to Australian and New Zealand standards and regulations.
- Avoid all contact with live electrical parts of the welding/cutting circuit, electrodes and wires with bare hands.
- The operator must wear dry welding gloves while he/she performs the welding/cutting task.
- The operator should keep the workpiece insulated from himself/herself.
- Keep cords dry, free of oil and grease, and protected from hot metal and sparks.
- Frequently inspect input power cable for wear and tear, replace the cable immediately if damaged, bare wiring is dangerous and can kill.
- Do not use damaged, undersized, or badly joined cables.
- Do not drape cables over your body.
- We recommend (RCD) safety switch is used with this equipment to detect any leakage of current to earth.



**Fumes and gases are dangerous.** Smoke and gas generated while welding or cutting can be harmful to people's health. Welding produces fumes and gases. Breathing these fumes and gases can be hazardous to your health.

- Do not breathe the smoke and gas generated while welding or cutting, keep your head out of the fumes.
- Keep the working area well ventilated, use fume extraction or ventilation to remove welding/cutting fumes and gases.
- In confined or heavy fume environments always wear an approved air-supplied respirator.
- Welding/cutting fumes and gases can displace air and lower the oxygen level, causing injury or death. Be sure the breathing air is safe.
- Do not weld/cut in locations near degreasing, cleaning, or spraying operations. The heat and rays of the arc can react with vapours to form highly toxic and irritating gases.
- Materials such as galvanised, lead, or cadmium plated steel, containing elements that can give off toxic fumes when welded/cut. Do not weld/cut these materials unless the area is very well ventilated, and or wearing an air-supplied respirator.



**Arc rays: harmful to people's eyes and skin.** Arc rays from the welding/cutting process produce intense visible and invisible ultraviolet and infrared rays that can burn eyes and skin.

- Always wear a welding helmet with the correct shade of filter lens and suitable protective clothing, including welding gloves while the welding/cutting operation is performed.
- Measures should be taken to protect people in or near the surrounding working area. Use protective screens or barriers to protect others from flash, glare and sparks; warn others not to watch the arc.



**Fire hazard.** Welding/cutting on closed containers, such as tanks, drums, or pipes, can cause them to explode. Flying sparks from the welding/cutting arc, hot workpiece, and hot equipment can cause fires and burns. Accidental contact of the electrode to metal objects can cause sparks, explosion, overheating, or fire. Check and be sure the area is safe before doing any welding/cutting.

- The welding/cutting sparks & spatter may cause fire, therefore remove any flammable materials well away from the working area. Cover flammable materials and containers with approved covers if unable to be moved from the welding/cutting area.
- Do not weld/cut on closed containers such as tanks, drums, or pipes, unless they are correctly prepared according to the required Safety Standards to ensure that flammable or toxic vapours and substances are totally removed, these can cause an explosion even though the vessel has been “cleaned”. Vent hollow castings or containers before heating, cutting or welding. They may explode.
- Do not weld/cut where the atmosphere may contain flammable dust, gas, or liquid vapours (such as petrol)
- Have a fire extinguisher nearby and know how to use it. Be alert that welding/cutting sparks and hot materials from welding/cutting can easily go through small cracks and openings to adjacent areas. Be aware that welding/cutting on a ceiling, floor, bulkhead, or partition can cause a fire on the hidden side.



**Gas Cylinders.** Shielding gas cylinders contain gas under high pressure. If damaged, a cylinder can explode. Because gas cylinders usually are part of the welding/cutting process, be sure to treat them carefully. CYLINDERS can explode if damaged.

- Protect gas cylinders from excessive heat, mechanical shocks, physical damage, slag, open flames, sparks, and arcs.
- Ensure cylinders are held secure and upright to prevent tipping or falling over.
- Never allow the welding/cutting electrode or earth clamp to touch the gas cylinder, do not drape welding cables over the cylinder.
- Never weld/cut on a pressurised gas cylinder, it will explode and kill you.
- Open the cylinder valve slowly and turn your face away from the cylinder outlet valve and gas regulator.



**Gas build-up.** The build-up of gas can cause a toxic environment, deplete the oxygen content in the air resulting in death or injury. Many gases used in welding/cutting are invisible and odourless.

- Shut off shielding gas supply when not in use.
- Always ventilate confined spaces or use approved air-supplied respirator.



**Electronic magnetic fields.** MAGNETIC FIELDS can affect Implanted Medical Devices.

- Wearers of Pacemakers and other Implanted Medical Devices should keep away.
- Implanted Medical Device wearers should consult their doctor and the device manufacturer before going near any electric welding, cutting or heating operation.



**Noise can damage hearing.** Noise from some processes or equipment can damage hearing.

- Wear approved ear protection if noise level is high.



**Hot parts.** Items being welded/cut generate and hold high heat and can cause severe burns.

- Do not touch hot parts with bare hands. Allow a cooling period before working on the welding/cutting gun. Use insulated welding gloves and clothing to handle hot parts and prevent burns.

## CAUTION

### 1. Working Environment.

- i. The environment in which this welding/cutting equipment is installed must be free of grinding dust, corrosive chemicals, flammable gas or materials etc., and at no more than a maximum of 80% humidity.
- ii. When using the machine outdoors, protect the machine from direct sunlight, rainwater and snow, etc.; the temperature of the working environment should be maintained within -10°C to +40°C.
- iii. Keep this equipment 30cm distant from the wall.
- iv. Ensure the working environment is well ventilated.

### 2. Safety Tips.

- i. **Ventilation:** This equipment is small-sized, compact in structure, and of excellent performance in amperage output. The fan is used to dissipate heat generated by this equipment during the welding/cutting operation. Important: Maintain good ventilation of the louvres of this equipment. The minimum distance between this equipment and any other objects in or near the working area should be 30 cm. Good ventilation is of critical importance for the normal performance and service life of this equipment.
- ii. **Thermal Overload Protection:** Should the machine be used to an excessive level, or in a high-temperature environment, poorly ventilated area or if the fan malfunctions the Thermal Overload Switch will be activated, and the machine will cease to operate. Under this circumstance, leave the machine switched on to keep the built-in fan working to bring down the temperature inside the equipment. The machine will be ready for use again when the internal temperature reaches a safe level.
- iii. **Over-Voltage Supply:** Regarding the power supply voltage range of the machine, please refer to the “Main parameter” table. This equipment is of automatic voltage compensation, which enables the maintaining of the voltage range within the given range. In case that the voltage of input power supply amperage exceeds the stipulated value, it is possible to cause damage to the components of this equipment. Please ensure your primary power supply is correct.
- iv. Do not come into contact with the output terminals while the machine is in operation. An electric shock may occur.

## MAINTENANCE

Exposure to extremely dusty, damp, or corrosive air is damaging to the welding/cutting machine. To prevent any possible failure or fault of this welding/cutting equipment, clean the dust at regular intervals with clean and dry compressed air of required pressure.

**Please note that:** lack of maintenance can result in the cancellation of the guarantee; the guarantee of this welding/cutting equipment will be void if the machine has been modified, attempt to take apart the machine or open the factory-made sealing of the machine without the consent of an authorized representative of the manufacturer.

## TROUBLESHOOTING

**Caution:** Only qualified technicians are authorized to undertake the repair of this welding/cutting equipment. For your safety and to avoid Electrical Shock, please observe all safety notes and precautions detailed in this manual.

# VIPER™ CUT 30 Plasma Cutter

**Key Features:**

- 10 AMP Plug
- Pilot Arc Start
- 12mm Clean Cut
- 14mm Severance

**1 YEAR  
PRODUCT  
WARRANTY**



TECHNICAL DATA	
SKU	KUPJRV30
PRIMARY INPUT VOLTAGE	240V Single Phase
SUPPLY PLUG	10A
RATED INPUT POWER (kVA)	7.5
RATED OUTPUT VOLTAGE (V)	92
AIR FLOW DRAW OFF (L/min)	170
AIR FLOW PRESSURE (Bar)	5-6 (70-87 psi)
PROTECTION CLASS	IP21S
INSULATION CLASS	F
MINIMUM GENERATOR (kVA)	8.0
DINSE CONNECTOR	Direct Connect
STANDARD	AS/NZ60974-1
WARRANTY (Years)	1

PLASMA CUT SPECIFICATIONS	
PLASMA CUT CURRENT RANGE	20-30A
PLASMA CUT DUTY CYCLE @ 40°C	15% @ 30A
MILD STEEL CUT THICKNESS	12mm
MILD STEEL SEVERANCE THICKNESS	14mm
ALUMINIUM CUT THICKNESS	6mm
ALUMINIUM SEVERANCE THICKNESS	8mm
STAINLESS STEEL CUT THICKNESS	6mm
STAINLESS STEEL SEVERANCE THICKNESS	8mm

SIZE & WEIGHT	
DIMENSIONS (mm)	460x160x320mm
WEIGHT (kg)	11.6kg

MACHINE FEATURES	
PLASMA ARC START	Pilot Arc
THERMAL OVERLOAD PROTECTION	Over Temperature Warning

## Recommended Accessories



**Plasma Cutter Air Filter**

50500

See page 15

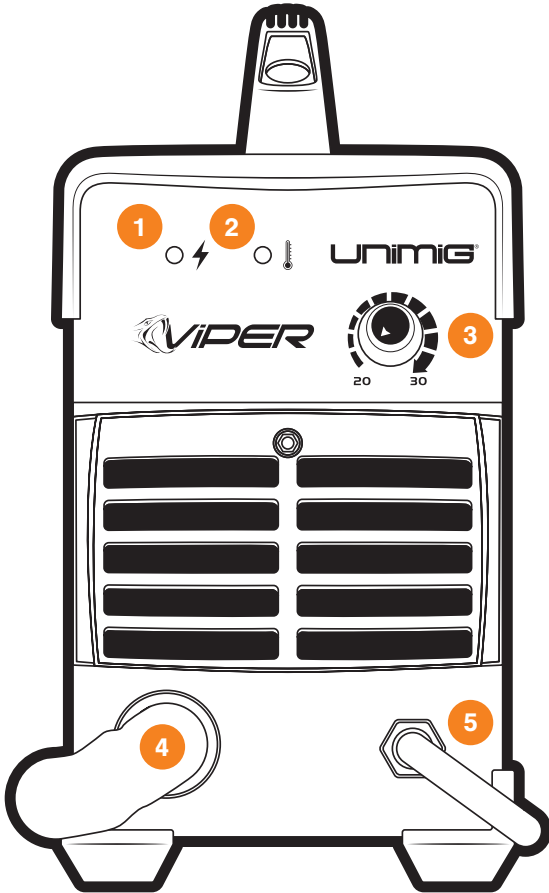

## Front Panel Layout

1. Mains Power LED
2. Over Current / Thermal Overload LED
3. Amperage Control Knob
4. Direct Connect SC30 Torch
5. Direct Connect Earth Clamp

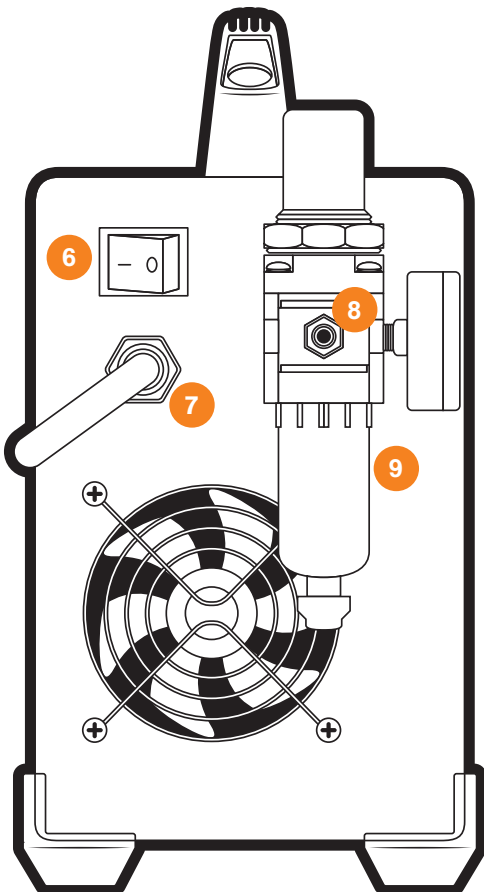

## Rear Panel Layout

6. On/Off Switch
7. Primary Power Input Cable
8. Air Supply Connector Inlet
9. Regulator

# WHAT'S IN THE BOX

---

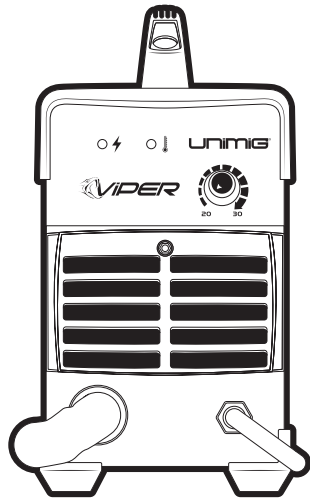

**VIPER CUT 30 Plasma Cutter**

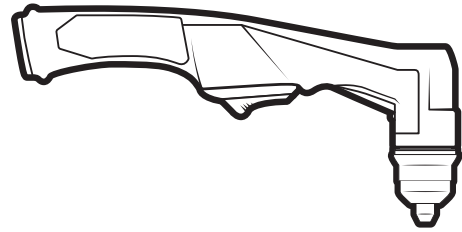

**4m Direct Connect SC30 Plasma Torch**

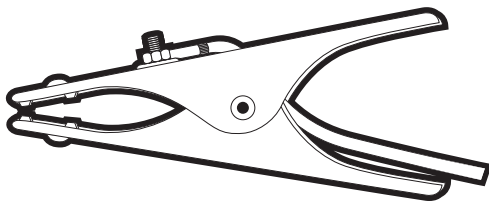

**4m Direct Connect Earth Clamp**

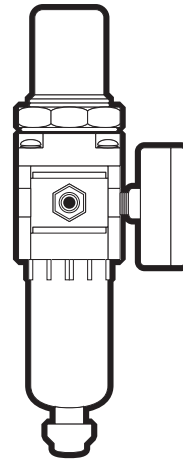

**Air Regulator**

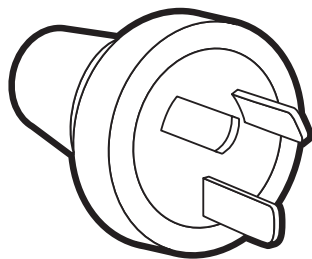

**10 AMP Plug (Fitted)**

**Operating Manual**

# SETUP FOR PLASMA CUTTING

- 1 Connect the earth clamp to the work piece.

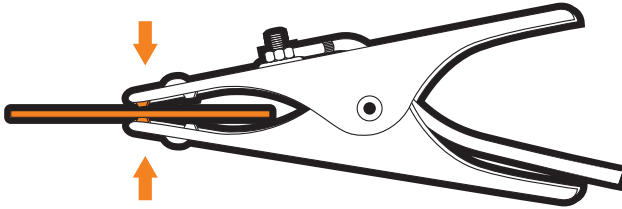

- 2 Connect the air supply to the regulator located at the rear of the machine. Set Air Pressure to 0.5MPa (75psi)

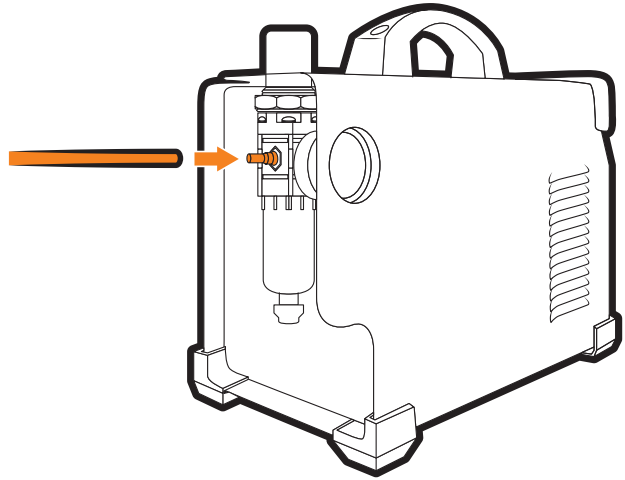

**WARNING: USE COMPRESSED AIR ONLY WITH THIS MACHINE**

- 3 Connect the machine to the correct power supply and switch on the machine using the on/off switch located at the rear of the machine.

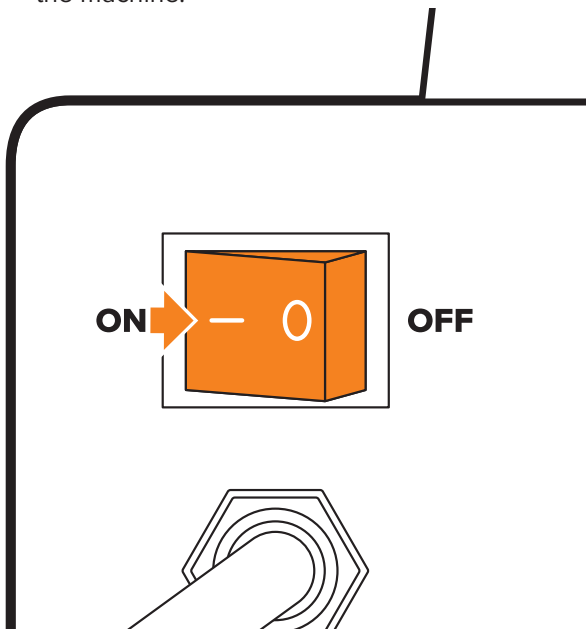

- 4 Connect the air supply to the regulator located at the rear of the machine. Set Air Pressure to 0.5MPa (75psi)

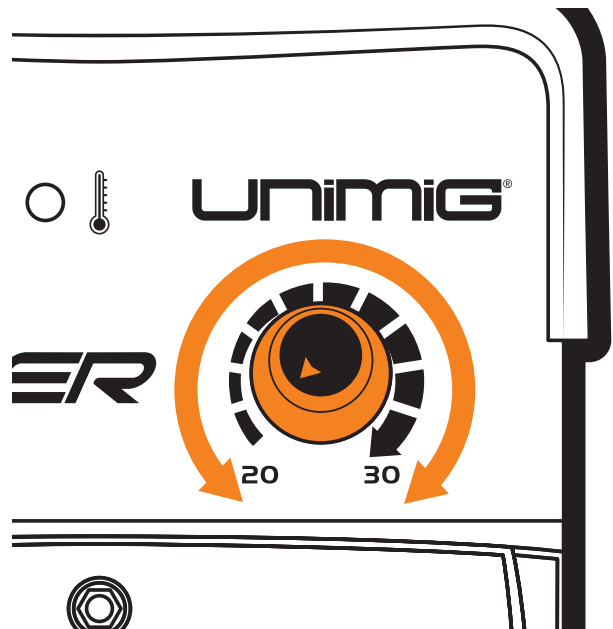

# SETUP FOR PLASMA CUTTING

- 5 Place and hold the torch vertical at the edge of the plate.

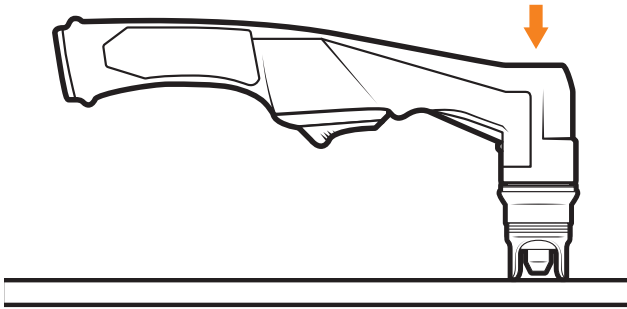

- 6 Pull the trigger to energise the arc. When the cutting arc has cut through the edge of the plate start moving evenly in the direction you wish to cut.

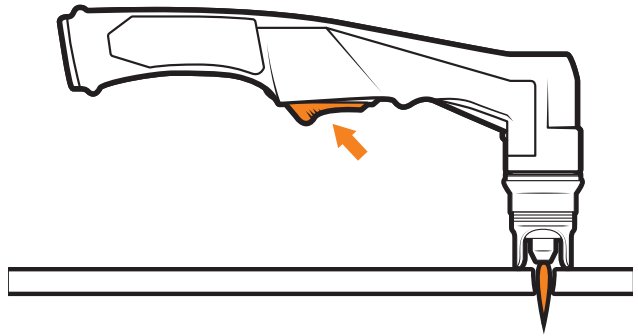

- 7 To finish the cutting release the torch switch. The air flow will continue for 30 seconds to cool the torch head. Do not disconnect air until this cooling period has been completed. Failure to do this will result in torch head damage.

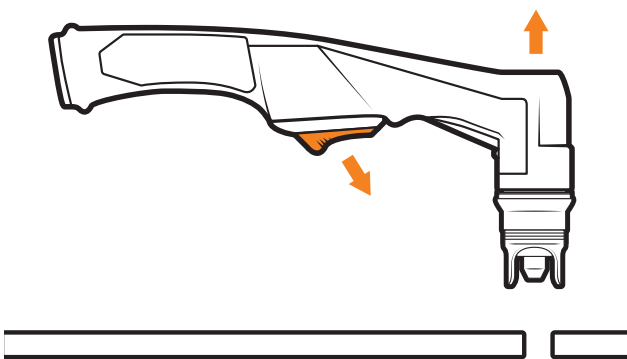

# PLASMA CUTTING PARAMETER GUIDE

---

The following parameters can be used as a guide to cutting different materials and thicknesses with the VIPER CUT 30. They are intended as a guide only, you may adjust depending on personal preference as well as the condition of the torch/material/air.

## VIPER CUT 30 - MILD STEEL PARAMETERS (75 PSI)

Material Thickness (mm)	Amps	Travel Speed (mm/min)
2-3mm	24A	360 mm/min
5-6mm	27A	340 mm/min
8-10mm	30A	240 mm/min
12mm	30A	200 mm/min

## VIPER CUT 30 - STAINLESS STEEL/ALUMINIUM PARAMETERS (75 PSI)

Material Thickness (mm)	Amps	Travel Speed (mm/min)
2-3mm	25A	360 mm/min
5mm	27A	300 mm/min
6mm	30A	300 mm/min

# PLASMA CUTTING TECHNOLOGY

Plasma cutters work by passing an electric arc through a gas that is passing through a constricted opening. The electric arc elevates the temperature of the gas to the point that it enters a 4th state of matter. We all are familiar with the first three: i.e., Solid, liquid, and gas. Scientists call this additional state plasma. As the metal being cut is part of the circuit, the electrical conductivity of the plasma causes the arc to transfer to the work. The restricted opening (Tip) the gas passes through causes it to squeeze by at high speed, like air passing through a venturi in a carburettor. This high-speed gas cuts through the molten metal. Plasma cutting was invented as a result of trying to develop a better welding process. Many improvements then led to making this technology what it is today. Plasma cutters provide the best combination of accuracy, speed, and affordability for producing a variety of flat metal shapes. They can cut much finer and faster than oxy-acetylene torches.

## How a plasma cutter works:

Basic plasma cutters use electricity to superheat air into plasma (the 4th state of matter), which is then blown through the metal to be cut. Plasma cutters require a compressed air supply and AC power to operate.

### Operation:

1. When the trigger is squeezed, DC current flows through the torch lead into the tip.
2. Next, compressed air flows through the torch head, through the air diffuser that spirals the airflow around the electrode and through the hole of the cutting tip.
3. A fixed gap is established between the electrode and the tip. (The power supply increases voltage in order to maintain a constant current through the joint.) Electrons arc across the gap, ionizing and superheating the air creating a plasma stream.
4. Finally, the regulated DC current is switched so that it no longer flows to the tip but instead flows from the electrode to the workpiece. Current and airflow continue until cutting is stopped.

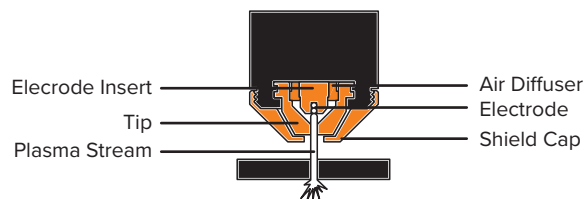

The nozzle and electrode require periodic replacement. The electrode has an insert of a tough high conductive material such as hafnium and cerium. This insert erodes with use; also, the tip orifice will erode with use. Quality of the air used is paramount to longer life of electrodes and tips, in short, clean dry air gives more extended parts life, the cleaner and dryer the better. We recommend the use of a Plasma Air Filter.

### What kinds of materials can the plasma cut?

Virtually any metal can be plasma cut including steel, stainless steel, aluminium, brass, copper, etc. Any thickness from 30 gauge through 30mm can be cut, depending on the power of the plasma cutter used.

### How Does Plasma Cutting Compare to Oxy-fuel (gas) cutting?

Plasma cutting can be performed on any conductive metal - mild steel, aluminium and stainless are some examples. With mild steel, operators will experience faster, thicker cuts than with alloys.

Oxy-fuel cuts by burning, or oxidizing the metal it is severanceing. It is therefore limited to steel and other ferrous metals which support the oxidizing process. Metals like aluminium and stainless steel form an oxide that inhibits further oxidization, making conventional oxy-fuel cutting impossible. Plasma cutting, however, does not rely on oxidation to work and thus it can cut aluminium, stainless and any other conductive material. While different gasses can be used for plasma cutting, most people today use compressed air for the plasma gas. In most shops, compressed air is readily available, and thus plasma does not require fuel gas and compressed oxygen for operation.

Plasma cutting is typically more accessible for the novice to master, and on thinner materials, plasma cutting is much faster than oxy-fuel cutting. However, for heavy sections of steel (25mm and greater), oxy-fuel is still preferred since oxy-fuel is typically faster and, for heavier plate applications, high powered plasma machines are required for plasma cutting applications.

### What are the limitations to Plasma Cutting? Where is Oxy-fuel preferred?

The plasma cutting machines are typically more expensive than oxy/acetylene. Also, oxy/acetylene does not require access to electrical power or compressed air which may make it a more convenient method for some users. Oxy-fuel can generally cut thicker sections (>25mm) of steel more quickly than plasma.

# PLASMA CUTTING TIPS & TECHNIQUES

## Amperage

The standard rule of thumb is the thicker the material, the more amperage required. On thick material, set the machine to full output and vary your travel speed. On thinner material, you need to turn down the amperage and change to a lower-amperage tip to maintain a narrow kerf. The kerf is the width of the cut material that is removed during cutting.

## Speed

Amperage and speed are critical to producing a good quality cut. The faster you move (especially on aluminium), the cleaner your cut will be. To determine if you're going too fast or too slow, visually follow the arc that is coming from the bottom of the cut. The arc should exit the material at a slight angle away from the direction of travel. If it's going straight down, that means you're going too slow, and you'll have an unnecessary build-up of dross or slag. If you go too fast, it will start spraying back onto the surface of the material without cutting all the way through. Because the arc trails at an angle, at the end of a cut, slow your cutting speed and angle the torch in to cut through the last bit of metal.

## Direction

It is easier to pull the torch towards you than push it. The plasma stream swirls as it exits the tip, biting one side and finishing off on the other, leaving a bevelled edge and a straight edge. The bevel cut effect is more noticeable on thicker material and needs to be taken into consideration before starting your cut as you want the straight side of the cut to be on the finished piece you keep.

## Torch tip height & position

The distance and position of the plasma torch cutting tip affect the quality of the cut and the extent of the bevel of the cut. The easiest way to reduce bevel is by cutting at the proper speed and height for the material and amperage that is being cut.

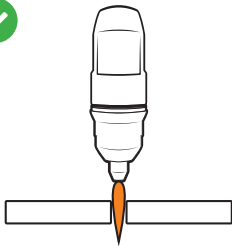

Correct torch height and square to the material.  
Minimum bevel & equal bevel  
Longest consumable life.

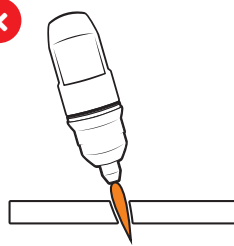

Torch angled to the material.  
Unequal bevel, one side may be excessively bevelled.

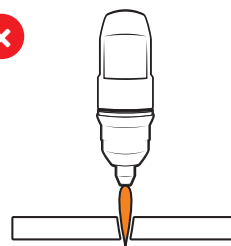

Torch height too high.  
Excessive bevel, plasma stream may not cut all the way through the material.

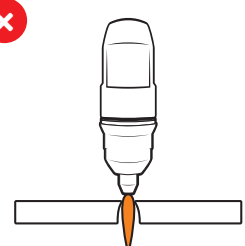

Torch height too low. Reverse bevel. The tip may contact the work and short out or damage the tip.

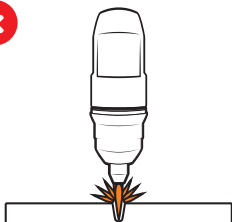

If sparks are spraying up from the work piece, you are moving the torch too fast, or you don't have enough amps set.

## Tip size and condition

The tip orifices focus the plasma stream to the workpiece. It is essential to use the correct size tip for the amperage being used, for example, a tip with a 1.0mm orifice is suitable for 0-40 amps whereas a 1.3mm orifice is better for 40-80 amps. The low-amp tip has a smaller orifice which maintains a narrow plasma stream at lower settings for use on thin-gauge material. Using a 25 amp tip at a 60 amp setting will blow out and distort the tip orifice and require replacement. Conversely, using an 80-amp tip on the lower settings will not allow you to focus the plasma stream as well and creates a wide kerf. The condition of the tip orifice is critical to the quality of the cut result, a worn or damaged tip orifice will produce a distorted plasma stream resulting in poor cut quality.

# PLASMA CUTTING TIPS & TECHNIQUES

## Electrode condition

A fixed gap is established between the electrode and the inside of the cutting tip — electrons arc across the gap, ionizing and superheating the air creating the plasma stream. The electrode contains an insert at the end made of a highly conductive material called hafnium. This insert erodes with use and develops a pit at the end of the electrode when the pit becomes too much poor-quality cuts will result and necessitate replacement of the electrode.

## Air pressure and volume

Air pressure, flow rate and air quality are critical to quality plasma cutting and consumable life span. The required air pressure and volume can vary from model to model, and the manufacturer will provide the specs.

The VIPER CUT 30 air pressure must be adjusted and set to 0.5MPa (75psi) and requires a flow rate of 190 L/min. The volume capacity of your compressor is important. If you have a small compressor with precisely the same L/min rating as the plasma, then the compressor will run continuously when you are plasma cutting. A compressor with a L/min rating slightly higher than the plasma would be more than adequate.

If you are doing a lot of cutting, cutting thick plate (same air consumption but slower cut speeds = longer cut time), then choose a compressor at 1.5 to 2 times the plasma system requirement.

## Air quality

Good air quality is essential to quality plasma cutting and consumable life span.

Compressors take in air at atmospheric pressure and increase the pressure and store it in a tank. Humidity in the air is condensed in the tank and the airlines producing water, more so in humid environments. Moisture that forms in airlines tends to condense into larger drops when the air pressure decreases as it is entering the plasma torch. When these droplets enter into the high temperatures (as much as 11,000°C) in the plenum of the torch, they immediately break down into oxygen and hydrogen, which alters the regular chemical content of the air in the torch. These elements will then dramatically change the plasma arc which causes the torch consumable parts to wear very quickly, alters the shape of the nozzle orifice, dramatically affecting cut quality in terms of edge squareness, dross formation, and edge smoothness.

Minimising the moisture in the air supply is absolutely critical to quality plasma cuts and longevity of consumable parts. As a minimum be sure to drain the receiver (tank) on the air compressor at least daily.

Most air plasma systems from reputable manufacturers have an onboard particulate filter and or a coalescing filter with an auto drain that will remove some moisture from the air supply. For home workshop and light industrial users, the onboard air filter is adequate. Most situations, however, will require additional filtration to prevent moisture from affecting the quality of the plasma cutter and in most cases, it is recommended to install a submicronic particulate filter that is designed to trap water through absorption. This style of filter has a replaceable filter cartridge that absorbs water and must be changed after it is near saturation; it should be installed close as possible to the air intake of the plasma cutter.

## Technique Tips

- It is easier to pull the torch through the cut than to push it.
- To cut thin material, reduce the amperage until you get the best quality cut.
- Use the correct size tip orifice for the amperage being used.
- For straight cuts use a straight edge or cutting buggy as a guide. For circles, use a template or circle cutting attachment.
- Check that the front end consumable parts of the plasma cutting torch are in good condition.



### Plasma Cutter Air Filter

SKU: 50500

*Most situations, however, will require additional filtration to prevent moisture from affecting the quality of the plasma cutter and in most cases, it is recommended to install a submicronic particulate filter that is designed to trap water through absorption.*

## SC30 Plasma Torch

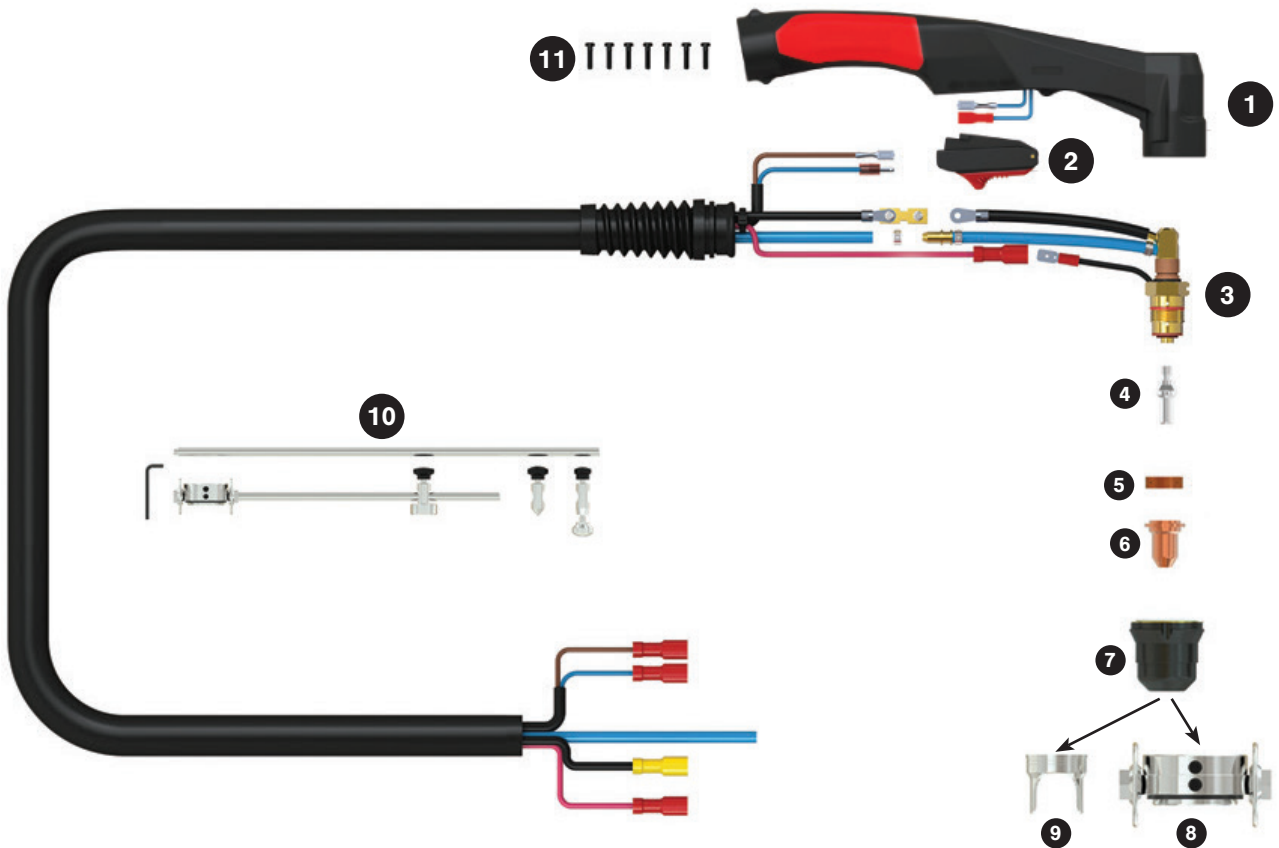

Length	4m
SKU	WGSC30P-40

TORCH SPARES		
1	SG5014R	Red Plasma Handle
2	SC2516R	Red Plasma Safety Trigger
3	SC3001	SC30 Torch Head
4	PWGSC2504	SC30 Electrode
5	WGSC2506	SC30 Swirl Ring
6	PWGSC2520-09	SC30 Cutting Tip
7	WGSC2530	SC30 Retaining Cap
8	WGSC2551	SC30 Cutting Buggy
9	WGSC2540	SC30 Standoff Guide
10	WGSC2550	SC30 Circle Cutting Attachment
11	SCSP1	Screw Pack to Suite Handle

TECHNICAL DATA	
COOLING METHOD	Air Cooled
DUTY CYCLE	60% @ 30A
CUTTING THICKNESS	8-12mm
GAS	Air/N2
GAS PRESSURE	4.5-5.0 Bar / 65-75 psi
GAS FLOW	40L/min
IGNITION	Pilot Arc
POST FLOW	90s
LENGTHS (m)	4
STANDARD	EN60974-7

**WARNING: There are extremely dangerous voltage and power levels present inside this unit. Do not attempt to diagnose or repair unit by removing external cover unless you are an authorised repair agent for UNIMIG.**

## **1. The cutting torch fails to ignite the arc when the torch trigger is pressed.**

- Gas pressure too high or too low, check and adjust gas pressure to 0.5MPA (75psi).
- The shield cup is not installed correctly, turn off the power source, install and screw it down properly, then turn on the power source.
- The electrode, swirl ring or cutting tip is not installed correctly, turn off the power source, install the electrode, swirl ring or cutting tip correctly, and screw shield cup down properly, then turn on the power source.

## **2. The cutting torch fails to ignite the arc when the torch trigger is pressed the temperature lamp is on.**

- Power Supply is overheated (OC/OT lamp on), let the unit cool down for at least 5 minutes. Make sure the unit has not been operated beyond Duty Cycle limit. Refer to page 8 for duty cycle specifications.
- Faulty components in unit return for repair.

## **3. No cutting output; Torch activated, power source on; Gas flows; Fan operates.**

- Torch not correctly connected to the power source, check that torch leads are correctly connected to the power source.
- Work cable not connected to the workpiece, or connection is weak, make sure that work cable has a proper connection to a clean, dry area of the workpiece.
- Faulty components in unit, return for repair
- Faulty torch, return for repair

## **4. Low cutting output**

- Incorrect setting of CURRENT (A) control, check and adjust to the proper setting.
- Faulty components in the unit, return for repair.

## **5. Difficult Starting**

- Worn torch parts (consumables), shut off input power. Remove and inspect torch shield cup, cutting tip, swirl ring and electrode. Replace electrode, cutting tip or swirl ring if worn; replace shield cup if excessive spatter has adhered to it.

## **6. Arc shuts off during operation; arc will not restart when the torch switch is activated.**

- Power Supply is overheated (OC/OT lamp on), let the unit cool down for at least 5 minutes. Make sure the unit has not been operated beyond Duty Cycle limit. Refer to Section 2 for duty cycle specifications.
- Torch consumables worn, check torch shield cup, swirl ring, cutting tip and electrode; replace as needed.
- Faulty components in unit return for repair.

## **7. No gas flow; the power LED on; Fan operates.**

- Gas not connected or pressure is too low, check gas connections. Adjust gas pressure to the proper setting.
- Faulty components in unit return for repair.

## **8. Torch cuts but low quality**

- Current (A) control set too low, increase the current setting.
- The torch is being moved too fast across the workpiece, reduce cutting speed.
- Excessive oil or moisture in torch, hold torch 1/8 inch (3 mm) from a clean surface while purging and
- Observe oil or moisture build-up (do not activate torch). If there are contaminants in the air, additional filtering may be needed. Refer to sub-micronic air filter page 15.







**HEAD OFFICE:**

112 Christina Rd,  
Villawood NSW 2163

PH: (02) 9780 4200  
FAX: (02) 9780 4210

EMAIL: [sales@unimig.com.au](mailto:sales@unimig.com.au)

**QLD OFFICE:**

180 Kerry Rd,  
Archerfield QLD 4108

PH: (07) 3333 2855  
FAX: (07) 3274 5829

EMAIL: [qld@unimig.com.au](mailto:qld@unimig.com.au)

**VIC OFFICE:**

91 Yellowbox Drive,  
Craigieburn VIC 3064

PH: (03) 8682 9911  
FAX: (03) 9333 7867

EMAIL: [vicsales@unimig.com.au](mailto:vicsales@unimig.com.au)

**WA OFFICE:**

Unit 2/29 Biscayne Way,  
Jandakot WA 6164

PH: (08) 6363 5111  
FAX: (08) 9417 4781

EMAIL: [wasales@unimig.com.au](mailto:wasales@unimig.com.au)