

UNIMIG ENVY



TIG230 AC/DC

Contents

1. Safety	4
2. Input Power Requirements	8
2.1 Circuit Breaker Recommendation	9
2.2 Welding Cable Leads Recommendation	9
2.3 Extension Cord Data	10
2.4 Generator Power Data	10
3. Package Contents	11
4. Technical Specifications	12
4.1 Machine Specifications	12
4.2 Equipment Identification	12
4.3 Duty Cycle & Overheating	13
4.4 Pinout	14
5. Machine Overview	15
5.1 Key Features	15
5.2 TIG Features	15
5.3 MMA Features	16
5.4 Machine Layout	17
6. Installation	18
6.1 Installing the Water Cooler (optional)	18
6.2 Installing Equipment on the Trolley (optional)	20
6.2.1 <i>Installing the Machine Only</i>	20
6.2.2 <i>Installing the Water Cooler & Machine</i>	21
6.3 Assembling a T2 TIG Torch	22
6.4 Connecting the TIG Torch	25
6.4.1 <i>Air Cooled Torch</i>	25
6.4.2 <i>Water Cooled Torch</i>	26
6.5 Connecting the MMA Electrode Holder	27
6.6 Connecting the Earth Clamp	28
6.7 Connecting a Foot Pedal	30
6.7.1 <i>Wired Foot Pedal</i>	30
6.7.2 <i>Wireless Foot Pedal</i>	30
6.8 Installing the Gas Bottle & Testing the Gas Flow	32
6.8.1 <i>Testing the Gas Flow</i>	33
6.9 Regulator Safety & Operation	34
6.10 Installing the Gas Bottle on the Trolley	36
7. Operation	37
7.1 Preparing for Operation	37
7.2 Control Panel Layout & Operation	38
7.3 MMA Mode	39
7.3.1 <i>Welding Parameters</i>	39
7.3.2 <i>Advanced Welding Parameters</i>	39
7.4 Lift TIG Mode	40
7.4.1 <i>Welding Parameters</i>	40

7.4.2 Advanced Welding Parameters.....	41
7.5 HF TIG Mode.....	42
7.5.1 Welding Parameters.....	42
7.5.2 Advanced Welding Parameters.....	43
7.6 Smart TIG Mode.....	44
7.6.1 Welding Parameters.....	44
7.6.2 Advanced Welding Parameters.....	45
7.7 Job Menu.....	46
7.7.1 Saving a Job.....	46
7.7.2 Overwriting a Job.....	46
7.7.3 Importing a Job.....	46
7.7.4 Exporting a Job.....	46
7.7.5 Deleting a Job.....	47
7.8 Settings Menu.....	48
7.8.1 Welding Parameters.....	48
7.9 Operating the Water Cooler.....	49
8. Maintenance.....	50
9. Troubleshooting.....	51
9.1 Machine Troubleshooting.....	51
9.2 TIG Troubleshooting.....	51
9.3 MMA Troubleshooting.....	52
9.4 Error Codes.....	53
10. General Welding Information.....	54
10.1 Metal Preparation.....	54
10.2 Beveling.....	55
11. TIG Welding Guide.....	56
12. MMA Welding Guide.....	65
13. Welding Settings Guides.....	68
13.1 TIG Fillet.....	68
13.2 TIG Butt.....	68
13.3 TIG Lap.....	69
14. Gas Selection.....	70
14.1 TIG.....	70
15. Welding Processes & Features Glossary.....	71
16. TIG Torch & Consumables.....	76
16.1 T2 TIG Torch.....	76
16.2 T2 TIG Torch Consumables.....	77
16.2.1 Standard TIG Setup.....	77
16.2.2 Standard Quartz TIG Setup.....	77
16.2.3 SUPER Series Ceramic TIG Setup.....	78
16.2.4 SUPER Series Quartz TIG Setup.....	78
17. Recommended Accessories.....	79

1. Safety

Welding equipment can be dangerous to both the operator and people in or near the surrounding working area if the equipment is not correctly operated. Equipment must only be used under the strict and comprehensive observance of all relevant safety regulations.

Read and understand this instruction manual carefully for all system components, especially the safety instructions and warning notices before the installation and operation of this equipment.

Product specifications and features are subject to change without notice. While every effort has been made to provide accurate and current information at the time of publication, this manual is intended as a general guide and is not exhaustive regarding safety, welding, or the operation and maintenance of this unit. Due to the many variables in the welding field and the evolving nature of both the field and the UNIMIG product line, Welding Guns of Australia Pty Ltd. does not guarantee the accuracy, completeness, authority, or authenticity of the information in this manual or provided by any UNIMIG employee during conversations or business dealings. The product owner assumes all liability for its use and maintenance. Welding Guns of Australia Pty Ltd. does not warrant this product or this document for fitness for any particular purpose, performance, accuracy, or suitability of application. Furthermore, Welding Guns of Australia Pty Ltd. accepts no liability for injury or damages, whether consequential or incidental, resulting from the use of this product or from the content of this document, nor does it accept third-party claims of such liability.

Note:

- Observe the accident prevention regulations and any regional regulations.
- Safety and warning labels on the machine indicate any possible risks.
- Keep these labels clean and legible at all times.
- Technical changes due to further development in machine technology may lead to different welding behaviour.

Items in the manual that require particular attention in order to minimise damage and harm are indicated with the below symbols. Read these sections carefully and follow their instructions.

 **Note:** Gives the user a useful piece of information.

 **Caution:** Describes a situation that may result in damage to the equipment or system.

 **Warning:** Describes a potentially dangerous situation. If not avoided, it will result in personal damage or fatal injury.

Machine Operating Safety

- Do not switch the function modes while the machine is operating. Switching of the function modes during welding can damage the machine. Damage caused in this manner will not be covered under warranty.
- Disconnect the electrode holder cable from the machine before switching on the machine to avoid arcing should the electrode be in contact with the workpiece.
- Only qualified persons should install, operate, maintain, and repair this equipment.
- During operation, keep everyone, especially children, away.



Electric Shock

Electric shock can kill. Touching live electrical parts can cause fatal shocks or severe burns. The electrode and work circuit is electrically live whenever the output is on. The input power circuit and internal machine circuits are also live when power is on. Incorrectly installed or improperly grounded equipment is dangerous.

- Connect the primary input cable according to Australian and New Zealand standards and regulations.
- Avoid all contact with live electrical parts of the welding circuit, such as sockets, tungstens and electrodes with bare hands.
- The operator must wear dry, hole-free welding gloves and body protection while they perform the welding task.
- The operator should keep the workpiece insulated from themselves.
- Keep cords dry, free of oil and grease, and protected from hot metal and sparks.
- Frequently inspect input power cable for wear and tear, and replace the cable immediately if damaged. Bare wiring is dangerous and can kill.
- Do not use damaged, undersized, or badly joined cables.
- Do not weld in the rain or in wet, moist, or damp areas.
- Do not drape cables over your body.
- Disconnect power source before servicing or maintaining this equipment.
- We recommend an RCD safety switch is used with this equipment to detect any leakage of current to earth.

⚠ DC voltage remains in the inverter power source after the removal of input power.



Arc Rays

Arc rays are harmful to your eyes and skin. Arc rays from the welding process produce intense visible and invisible ultraviolet and infrared rays that can burn eyes and skin.

- Always wear an approved welding helmet with the correct shade of filter lens and suitable protective clothing, including welding gloves, while the welding operation is performed.

Recommended filter shades for arc welding

Less than 150A	Shade 10*
150A to 250A	Shade 11*
250A to 300A	Shade 12
300A to 350A	Shade 13
Over 350A	Shade 14

**Use one shade darker for aluminium.*

- Wear safety glasses under your helmet.
- Measures should be taken to protect people in or near the surrounding working area. Use protective screens or barriers to protect others from flash, glare and sparks; warn others not to watch the arc.
- Wear proper PPE and body protection made from durable, flame-resistant materials like leather.

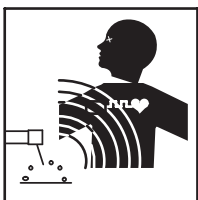

Electro Magnetic Fields (EMF)

Magnetic fields can affect Implanted Medical Devices.

- Wearers of Pacemakers and other Implanted Medical Devices should keep away.
- Implanted Medical Device wearers should consult their doctor and the device manufacturer before going near any arc welding.



Fire Hazard

Welding on closed containers, such as tanks, drums, or pipes, can cause them to explode. Flying sparks from the welding arc, hot workpiece, and hot equipment can cause fires and burns. Accidental contact of the electrode with metal objects can cause sparks, explosions, overheating, or fire. Check and be sure the area is safe before doing any welding.

- Remove any flammable materials well away from the working area. Cover flammable materials and containers with approved covers if they cannot be moved from the area.
- Do not weld on closed containers or containers that have held combustible materials, such as tanks, drums, or pipes, unless they are correctly prepared according to the required Safety Standards to ensure that flammable or toxic vapours and substances are totally removed, these can cause an explosion even though the vessel has been “cleaned”.
- Vent hollow castings or containers before welding. They may explode.
- Do not weld where the atmosphere may contain flammable dust, gas, or liquid vapours (such as petrol).
- Have a fire extinguisher nearby and know how to use it.
- Be alert that welding sparks and hot materials from welding can easily go through small cracks and openings to adjacent areas.
- Be aware that welding on a ceiling, floor, bulkhead, or partition can cause a fire on the hidden side.
- Avoid welding on tire rims or wheels, as heating can cause tires to explode and repaired rims may fail.
- Attach the earth clamp as close as possible to the welding area to minimise the risk of electric shock, sparks, and fire hazards caused by the welding current travelling through long or unknown paths.
- When not in use, ensure the MMA electrode is removed from its holder.
- Before welding, remove any combustible items, like butane lighters or matches, from your person.
- Post welding, thoroughly inspect the area to ensure there are no lingering sparks, glowing embers, or flames.
- Always use the correct fuses or circuit breakers, and don't oversize or bypass them.
- Wear proper PPE and body protection made from durable, flame-resistant materials like leather.
- Read and understand the Safety Data Sheets (SDSs) and the manufacturer's instructions for adhesives, coatings, cleaners, consumables, coolants, degreasers, fluxes, and metals.



Hot Parts

Hot parts can burn. Items being welded can generate and hold high heat and can cause severe burns.

- Do not touch hot parts with bare hands.
- Allow a cooling period before working on the welding equipment.
- Use the proper tools and insulated welding gloves and clothing to handle hot parts and prevent burns.



Noise Hazards

The noise from some processes or equipment can damage hearing.

- Wear approved ear protection if the noise level is high.



Gas Cylinders

Shielding gas cylinders contain gas under high pressure. If damaged, a cylinder can explode. Because gas cylinders are usually part of the welding process, be sure to treat them carefully.

- Protect gas cylinders from excessive heat, mechanical shocks, physical damage, slag, open flames, sparks, and arcs.
- Ensure cylinders are secured upright to prevent tipping or falling over.
- Never allow the welding electrode, earth clamp, or electrical circuit to touch the gas cylinder, and don't drape welding cables over the cylinder.
- Never weld on a pressurised gas cylinder, it will explode and kill you.
- Open the cylinder valve slowly and turn your face away from the cylinder outlet valve and gas regulator. Stand to the side of the cylinder when opening the valve.
- Only use the correct gas, regulators, hoses, and fittings for your application and keep them in good condition.
- Keep full and empty cylinders separate.
- Keep ammonia-based leak detection solutions, oil and grease away from cylinders and valves.
- Never use force when opening or closing valves.
- Don't repaint or disguise markings and damage. If damaged, return cylinders immediately.
- When working with cylinders or operating cylinder valves, ensure that you wear appropriate protective clothing – gloves, boots and safety glasses.



Fumes & Gases

Fumes and gases are dangerous. Welding produces fumes and gases and breathing these fumes and gases can be hazardous to your health.

- Do not breathe the smoke and gas generated while welding. Keep your head out of the fumes.
- Keep the working area well-ventilated and use fume extraction or ventilation to remove welding fumes and gases.
- In confined or heavy fume environments, always wear an approved air-supplied respirator.
- Welding fumes and gases can displace air and lower the oxygen level, causing injury or death. Be sure the breathing air is safe.
- Do not weld in locations near degreasing, cleaning, or spraying operations. The heat and rays of the arc can react with vapours to form highly toxic and irritating gases.
- Materials such as galvanised, lead, or cadmium-plated steel contain elements that can give off toxic fumes when welded. Do not weld these materials unless the coating is removed, or the area is very well-ventilated and/or you are wearing an air-supplied respirator.
- Read and understand the Safety Data Sheets (SDSs) and the manufacturer's instructions for adhesives, coatings, cleaners, consumables, coolants, degreasers, fluxes, and metals.



Gas Buildup

The build-up of gas can cause a toxic environment and deplete the oxygen content in the air resulting in death or injury. Many gases used in welding are invisible and odourless.

- Shut off the shielding gas supply when not in use.
- Always ventilate confined spaces or use an approved air-supplied respirator.



PLEASE NOTE that under no circumstances should any equipment or parts be altered or changed in any way from the standard specification without written permission given by UNIMIG.

To do so will void the warranty.

2. Input Power Requirements

UNIMIG welding machines are designed and manufactured to conform to **IEC 60974** or **AS 60974** standards. This Standard covers the safety and performance requirements of welding power sources and plasma cutting systems. This includes the **machine**, the **input cable**, and the **plug** requirements like the size of the plug that should be used.

Maximum effective supply current (I_{eff}) according to AS 60974.1

$$I_{\text{eff}} = \sqrt{I_1^2 \times X + I_0^2(1-X)}$$

- I_0 Rated no-load supply current
- I_1 Rated supply current
- X Rated duty cycle

The I_{eff} identifies the appropriate plug, input cable, and input current necessary for each device.

	Min-Max Cable Size
$I_{\text{eff}} \leq 10A$	1.5-2.5mm ²
$I_{\text{eff}} \leq 15A$	1.5-4.0mm ²
$I_{\text{eff}} \leq 25A$	2.5-6.0mm ²
$I_{\text{eff}} \leq 32A$	4.0-10.0mm ²

⚠ Don't risk damage to your machine or cause tripping and/or fire by using the wrong input current, cable or plug. Don't tamper with the plugs or file down earth pins. Doing so will void your warranty.

For your safety, UNIMIG meets the AS/NZS Standards for safe electrical compliance

All UNIMIG machines undergo an independent certification process to meet Australian and New Zealand regulations regarding electrical safety.



The triangle-circle-tick (RCM) symbol signifies that UNIMIG has taken the necessary steps to have the product comply with the electrical safety and/or electromagnetic compatibility (EMC) legislative requirements as specified by the Electrical Regulatory Authorities Council (ERAC). For your safety, please check for this symbol before buying any welding machine in Australia and New Zealand.

Depending on the specific machine, it may be necessary for UNIMIG to use a 32A single-phase plug. This is to make sure that the input supply plug and lead remain cool and do not overheat when the machine operates at its maximum capacity.

Check the rating plate on your machine

All welding machines that comply with **IEC 60974** or **AS 60974** must have a data plate similar to the one shown.

Welding machines draw some current when not welding, a higher current when welding, and a surge current when initiating an arc.

The effective rated primary current (I_{eff}) combines the conductor heating due to these levels of current. I_{eff} is the maximum rated effective supply current that determines the minimum plug and input cable rating as well as the minimum capacity of the input circuit that the machine gets plugged into to safely operate the machine.

Look for the I_{eff} on the welding machine's rating plate and ensure that you have the correct input circuit to support this power draw.

Example: If the I_{eff} rating on your machine is 27A then you must use a 32A plug, as a 15A plug is undersized for the welding current being used and may cause the cable to overheat.

UNIMIG		PART NO. U11024	
ENVY TIG 230 AC/DC		STANDARD AS 60974.1	
10A			
\sim	2A/10.1V-230A/19.2V	\sim	2A/10.1V-230A/19.2V
X	15% 60% 100%	X	15% 60% 100%
I_0	230A 115A 89A	I_0	230A 115A 89A
I_1	19.2V 14.8V 13.6V	I_1	19.2V 14.8V 13.6V
I_{eff}	U=100V I=28A I=9.7A	I_{eff}	U=100V I=28A I=9.7A
I_{eff}	U=240V I=28A I=9.7A	I_{eff}	U=240V I=28A I=9.7A
\sim	10A/20.4V-200A/28.0V	\sim	10A/20.4V-200A/28.0V
X	10% 60% 100%	X	10% 60% 100%
I_0	200A 82A 63A	I_0	200A 82A 63A
I_1	28.0V 23.3V 22.5V	I_1	28.0V 23.3V 22.5V
I_{eff}	U=100V I=28.3A I=9.3A	I_{eff}	U=100V I=28.3A I=9.3A
I_{eff}	U=240V I=28.3A I=9.3A	I_{eff}	U=240V I=28.3A I=9.3A
15A			
\sim	2A/10.1V-230A/19.2V	\sim	2A/10.1V-230A/19.2V
X	35% 60% 100%	X	35% 60% 100%
I_0	230A 115A 89A	I_0	230A 115A 89A
I_1	19.2V 17.0V 15.4V	I_1	19.2V 17.0V 15.4V
I_{eff}	U=100V I=28A I=14.8A	I_{eff}	U=100V I=28A I=14.8A
I_{eff}	U=240V I=28A I=14.8A	I_{eff}	U=240V I=28A I=14.8A
\sim	10A/20.4V-200A/28.0V	\sim	10A/20.4V-200A/28.0V
X	25% 60% 100%	X	25% 60% 100%
I_0	200A 129A 100A	I_0	200A 129A 100A
I_1	28.0V 25.2V 24.0V	I_1	28.0V 25.2V 24.0V
I_{eff}	U=100V I=29.3A I=14.7A	I_{eff}	U=100V I=29.3A I=14.7A
I_{eff}	U=240V I=29.3A I=14.7A	I_{eff}	U=240V I=29.3A I=14.7A
1-50-60Hz IP21S H AF 20.5kg			

How important is the correct input cable and plug on a welding machine?

The size of the plug depends on the above formula, which uses the maximum current draw as well as the duty cycle of the power source. The use of any welding power source will not only cause the machine itself to heat up but the input cable, plug, and mains power as well.

That's why it's important to understand input and output currents and to make sure that the input circuit is correctly rated to supply the required input draw. This allows the machine to operate at or near maximum output and protects the circuit board from tripping, overheating and/or catching fire.

What if I don't have a 240volt 15amp or 32amp outlet?

If you don't have a suitable power outlet, you should contact a qualified electrician to advise whether the wiring in your building will cater for a 15amp or 32amp outlet. You may also need to upgrade your circuit breakers and possibly switchboard to suit. Failure to do this may cause an electrical fire in the building which may void insurances.

Make sure you:

- ✓ Use the correct input current cable and plug in accordance with **AS 60974.1** for your safety and to get the maximum performance from your welding machine.
- ✓ Inspect cables and plugs regularly.
- ✓ Contact a qualified electrician for advice and/or upgrade and, if needed, to replace any damaged plugs or cables.

2.1 Circuit Breaker Recommendation

The maximum input current (I_{max}) will determine the size of the circuit breaker that should be installed in order to run the machine continuously without risk of voltage drops from the circuit breaker to the plug outlet.

The recommended circuit breaker for this machine is 32A.

 This recommendation is distinct from the effective current (I_{eff}), which dictates the size of the input plug.

2.2 Welding Cable Leads Recommendation

Welding cables are crucial electrical conductors for the welding current. The appropriate thickness of the welding cable is dictated by the machine's maximum amperage and the length of cable needed. It is essential that both the earth clamp and the electrode holder are equipped with adequately sized welding cable leads to maintain effective operation.

Current (A)	Duty Cycle (%)	Lead thickness (mm ²) based off combined lengths of electrode and earth cable				
		Up to 15m	16-30m	31-45m	46-60m	61-75m
125	30	10	16	25	35	50
150	40	10	16	25	35	50
180	30	25	25	35	50	50
200	60	35	35	35	50	50
225	30	25	25	50	50	50
250	30	25	25	50	50	50
275	60	50	50	50	70	95
300	60	50	50	70	70	95
350	60	50	50	70	95	120
400	100	70	70	95	95	120
500	100	70	95	95	95	120

2.3 Extension Cord Data

See the table below as a guide based on the minimum necessary input power (in this case, 20A):

Cord thickness/Cable size (mm ²)	Maximum length of cord (m)
2.5	30
4.0	50

Using an extension lead that is too small, or using it over a longer distance than recommended, will lead to voltage drops and cause problems with power supply.

⚠ Not following these recommendations can cause insufficient power, which can lead to unstable arc behaviour, reduced penetration, and poor weld quality.

2.4 Generator Power Data

Operate this unit only with clean power generators that provide a surge capacity of 8,000 watts or more. The generator should limit Total Harmonic Distortion (THD) to 5% or below, as this level of THD is deemed 'clean' and comparable to conventional shop power. Usage of generators that don't meet the clean power standard (5% or lower THD) is not recommended.

⚠ Not following these recommendations can cause insufficient power, which can lead to unstable arc behaviour, reduced penetration, and poor weld quality. In some instances it can also cause damage to your equipment.

3. Package Contents

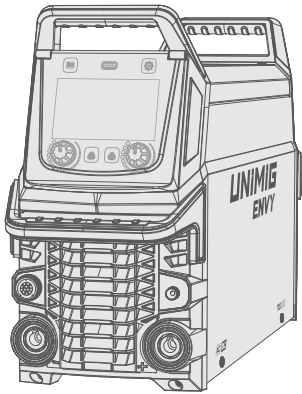
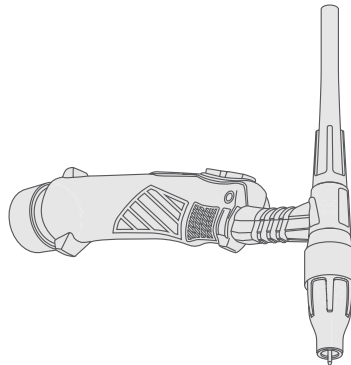
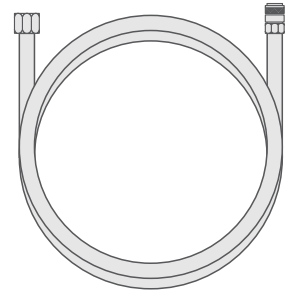
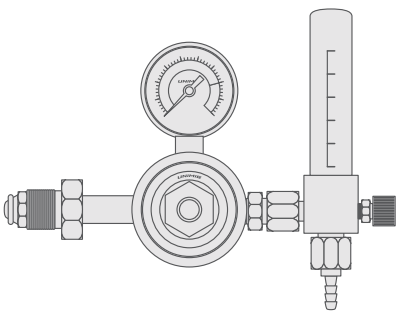
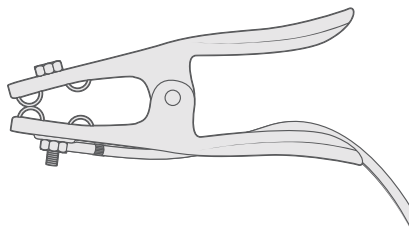
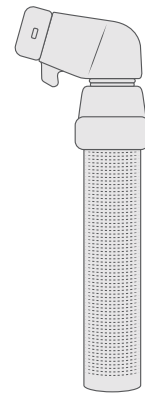
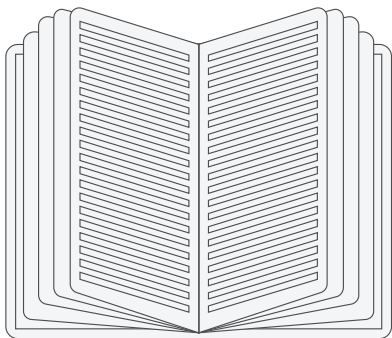
**ENVY TIG 230 AC/DC Welder****8m T2 TIG Torch****Quick Connect Gas Hose****Argon Flowmeter****300A Earth Clamp****400A Electrode Holder****Manual**

4. Technical Specifications

4.1 Machine Specifications

Technical Data

Parameter	Values
SKU	U11024
Primary Input Voltage	240V Single Phase 50/60Hz
Supply Plug	10/15A
I _{eff} (A)	9.7A (10A) / 14.8A (15A)
I _{max} (A)	29.3A
Rated Output	2-230A
No Load Voltage (V)	100V
Protection Class	H
Insulation Class	IP21S
Minimum Generator (kVA)	8.0
Dinse Connector	35/50
Standard	AS 60974.1
Welds	TIG: Aluminium, Magnesium, Zinc Alloys, Mild Steel, Stainless Steel, Copper, Silicon Bronze, Titanium MMA: Mild Steel, Stainless Steel, Cast Iron
Warranty (Years)	5

TIG Specifications

Parameter	Values
TIG Function Type	AC/DC HF TIG & AC/DC Pulse
TIG Welding Current Range	2-230A
TIG Duty Cycle @ 40°C	15% @ 230A, 60% @ 115A, 100% @ 89A (10A) 35% @ 230A, 60% @ 176A, 100% @ 136A (15A)
TIG Welding Thickness Range	1-12mm

MMA Specifications

Parameter	Values
STICK Welding Current Range	10-200A
STICK Duty Cycle @ 40°C	10% @ 200A, 60% @ 82A, 100% @ 63A (10A) 20% @ 200A, 60% @ 115A, 100% @ 90A (15A)
STICK Electrode Range	2.5-4.0mm
STICK Welding Thickness Range	2-12mm

Size & Weight

Parameter	Values
Dimensions (mm)	680x210x395mm
Weight (kg)	20.6kg

4.2 Equipment Identification

Serial Number

The serial number of the device is marked below the data plate on the underside of the machine. It is important to make correct reference to the serial number of the product when ordering spare parts or making repairs, for example.

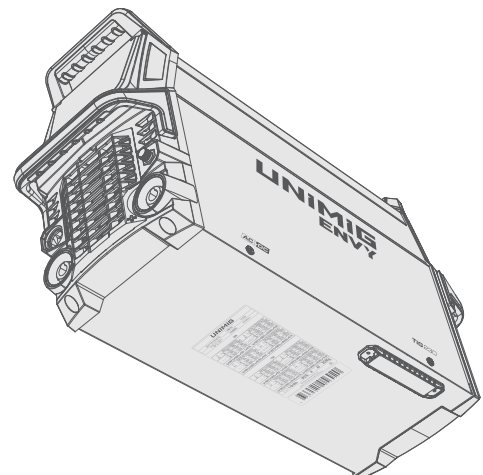

4.3 Duty Cycle & Overheating

The duty cycle is how long a machine can continuously weld at a selected amperage over a 10-minute period before the thermal overload protection kicks in.

TIG (10A Mode) - 15% @ 230A, at 40°C ambient temperature



TIG (15A Mode) - 35% @ 230A, at 40°C ambient temperature

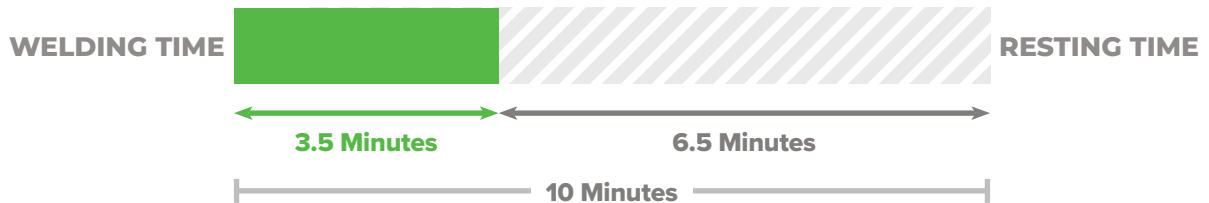

MMA (10A Mode) - 10% @ 200A, at 40°C ambient temperature

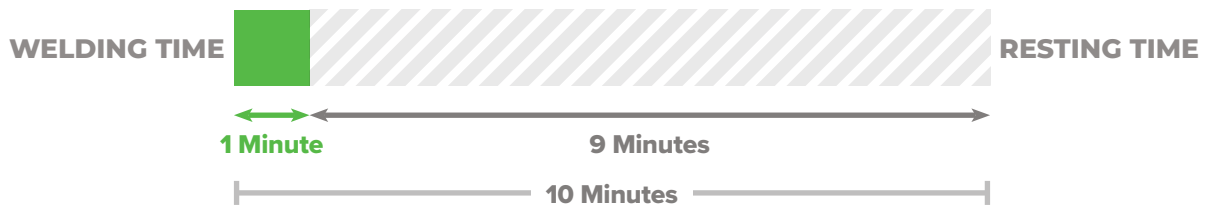

MMA (15A Mode) - 20% @ 200A, at 40°C ambient temperature

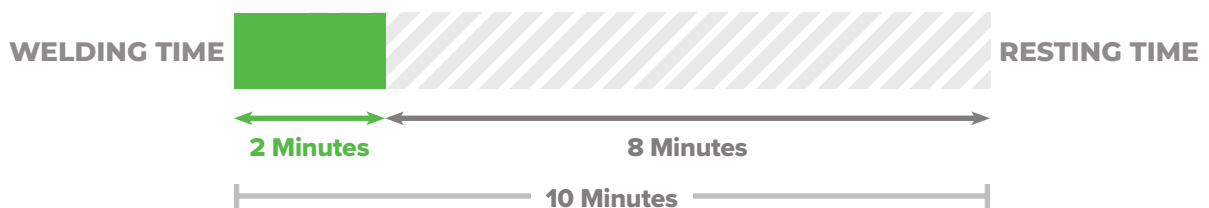

4.4 Pinout

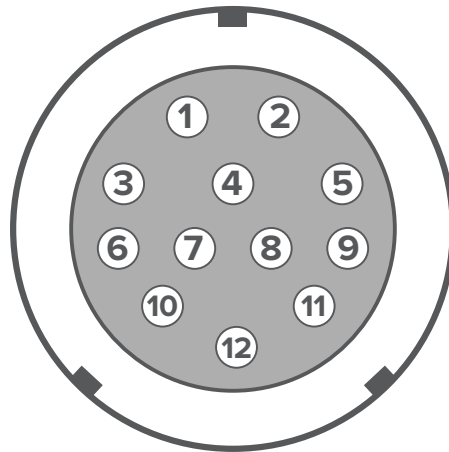

PIN Number	Standard TIG Torch Connection
1	Push Pull/Spool Gun Motor (+)
2	Push Pull/Spool Gun Motor (-)
3	Trigger (Tig + Tig Pedal)
4	Ground (Trigger Tig + Trigger Tig Pedal + Toggle Up/Down Ground + Digital Torch Ground)
5	Potentiometer Min (Tig + Spool Gun + Push Pull Gun)
6	Potentiometer Max (Tig + Spool Gun + Push Pull Gun)
7	Potentiometer Common (Tig + Spool Gun + Push Pull Gun)
8	Toggle Up Signal (Tig Torch)
9	Toggle Down Signal (Tig Torch)
10	Digital Torch Signal Tx
11	Digital Torch Signal Rx
12	Digital Torch Power (+)

5. Machine Overview

5.1 Key Features

Silicon Carbide Technology

The first of its kind, the new silicon carbide (SiC) MOSFET is the next-generation of semiconductor technology.

The silicon carbide MOSFET can easily achieve a high switching frequency of 100K. With a higher switching frequency, the high-frequency characteristics are improved, and the machine's main frequency is increased to 100kHz, more than double that of a traditional IGBT, and with less conductor resistance.

This higher frequency and a low conduction resistance means the DC current's waveform ripple is smaller, providing a more stable output, better arc characteristics, and finer control over the arc.

These SiC MOSFETs are smaller, and this reduction in size minimises the electrical loss, and increases the energy efficiency, surpassing that of traditional IGBT technology.

Silicon carbide MOSFETs have a significantly higher impact resistance and temperature resistance compared to traditional ones. The higher impact resistance allows it to withstand higher voltages, while the increase in temperature resistance (150°C vs 120°C) means that it will perform well even in higher temperatures.

Our new MOSFET IGBT works to make the machine more reliable, with a superior arc performance and better weld quality compared to previous IGBT technology.

Smart Fan

Smart Fan diminishes noise, saves power, helps reduce energy costs, and minimises the number of contaminants being pulled through the machine.

Power Factor Correction (PFC)

Get the most out of your machine. The PFC maximises the electrical efficiency of the machine and automatically compensates for any voltage fluctuations, so you get more output power and the internal components last longer.

Job Memory

The job memory function allows you to enter and store weld parameter settings. Weld parameters can be further adjusted and stored as required. A total of 100 Jobs can be memorised and stored for recall.

5" Colour LCD Touchscreen

Change settings with ease with the intuitive touchscreen controls and next-generation user interface.

Generator Compatible

Going off the grid? The ENVY TIG 230 AC/DC can be connected to a generator, we recommend one with at least 8kVA.

IP21S Rating

Rated IP21S, so it's protected from touch by fingers and objects greater than 12mm, and water spray from a vertical direction.

Foot Control Ready

This machine supports the connection of both a wired or wireless foot control for extra versatility and convenience while welding. You can adjust your amperage hands-free to avoid disrupting your torch movement, and the wireless option reduces cables and adds greater manoeuvrability as well.

5.2 TIG Features

Speed Start™

Speed up the formation of the weld puddle by applying a synergic pulse program to the beginning of the weld. The initial pulse works to melt the joint edges faster, for quicker puddle formation compared to a standard arc start.

Steady Arc™

Steady Arc adjusts the welding current based on the arc voltage. When the voltage goes down, the amperage will go up, and vice versa, to give a consistent weld puddle, a sharper arc and a constant heat input. Weld speeds can be increased with no fluctuations in the weld current.

TackPlus™

TackPlus is a tack welding program used to create evenly spaced and sized fusion tack welds along a joint with minimal heat input.

Amplitude Control

Amplitude Control adjusts the percentage of the AC waveform that is on the negative side for a more penetrative weld. Increasing the percentage of electrode negative puts more heat into the base plate, allowing for greater penetration, a narrower arc, plus faster weld speeds and metal deposition.

TIG Smart-Set™

The easiest way to set up for a TIG weld, simply set your filler material, joint type, tungsten diameter, and material thickness and you're good to go!

Mixed AC/DC

Experience the best of both worlds. Mixed AC/DC combines the efficiency of AC and the penetration of DC- TIG in one weld. With it, you get faster welding speeds, better penetration, a faster weld puddle on cold workpieces, and you can weld thicker materials.

Tungsten Optimiser

Select the tungsten diameter and get an optimised welding arc ignition in both AC and DC TIG based on the chosen diameter.

Heat Control Trigger (HCT) Mode

Heat Control Trigger Mode lets you set a base current, which you can switch to at any time during a weld by pressing the trigger button. Heat Control Trigger Mode is great for manual heat input control as you go.

Low Amp TIG with Stable Arc

Maintain a stable arc even when TIG welding as low as 2A. The new and improved SiC MOSFET technology means you can hold a steady arc no matter how low your amperage.

Cap Shaping

Get the perfect tungsten shape for your aluminium welds every time with just the click of the trigger. Turn the cap shaping feature on, press the torch trigger, and the machine will prep the optimal tungsten shape for your aluminium welds.

AC & DC Waveforms

Customise your waveform in both DC and AC weld modes. Choose from your preferred welding waveform or use a combination of two to adjust the arc characteristics to suit your welding needs.

Higher Pulse Frequency in AC & DC

With a pulse frequency as high as 999 pulses per second in both AC and DC TIG, you can get as many pulses as you need for any scenario.

5.3 MMA Features

MMA (STICK)

You'll be able to weld anything, including cellulosic electrodes.

Pulse MMA

Pulse MMA welding helps reduce spatter, improves heat control and allows for an easier removal of slag. It also improves the speed and efficiency of vertical up welds by eliminating the use of the "Christmas Tree" technique, while still maintaining root fusion.

Hot Start

The Hot Start feature gives a boost of current at the beginning of your weld, stabilising your ignition and eliminating any issues with striking an arc, especially on difficult electrodes.

Arc Force

The Arc Force feature helps to keep the arc stabilised throughout the weld, by increasing or decreasing the peak current to compensate for your arc length, preventing the arc from cutting out or the electrode from sticking.

Anti Stick

The Anti Stick feature, which is always on, prevents your electrode from sticking to your workpiece. When the machine detects sticking, the current will drop significantly, so the electrode can be removed.

5.4 Machine Layout

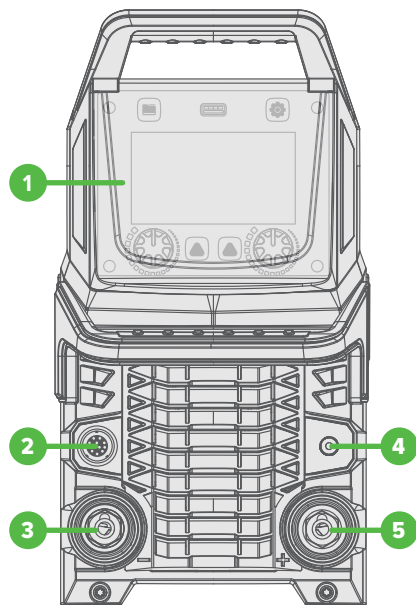

Front Panel Layout

1. Display Panel
2. 12 Pin Outlet
3. Negative Dinse Connector (-)
4. Gas Outlet
5. Positive Dinse Connector (+)

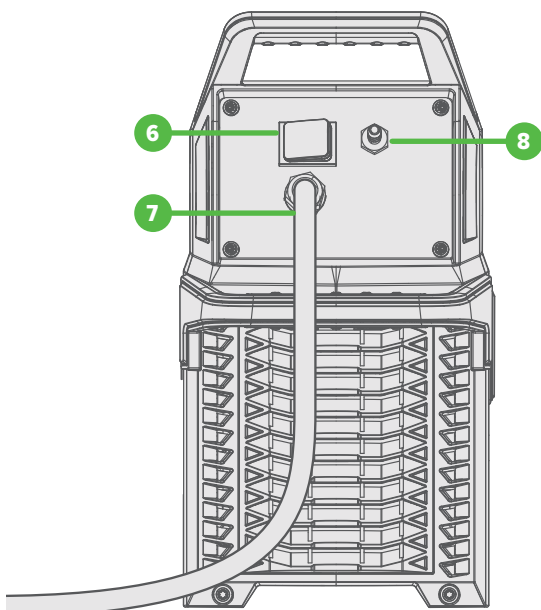

Back Panel Layout

6. Power Switch
7. Power Cable
8. Gas Inlet

6. Installation

6.1 Installing the Water Cooler (optional)

⚠ Do not connect the equipment to the mains before the installation is complete.

i When a trolley is used, refer also to *"Installing Equipment on the Trolley (optional)"* on page 20.

1. Remove the water cooler cover from the bottom of the machine. This can be completely removed or locked into place in the holder.

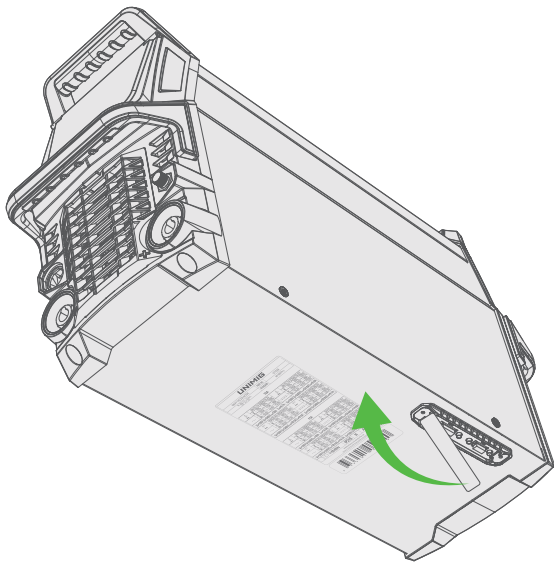

2. Place the machine on top, lining it up so the water cooler connection port lines up and the feet of the machine sit over the mounting brackets. Unscrew the four screws in the two mounting brackets on the top of the water cooler if they are already installed.

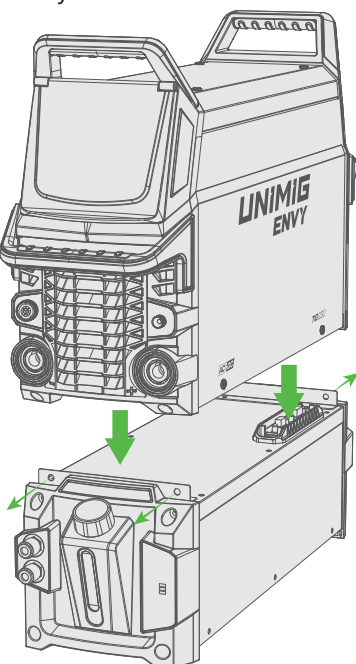

3. Screw the four screws back into the feet of the machine into the mounting bracket holes.

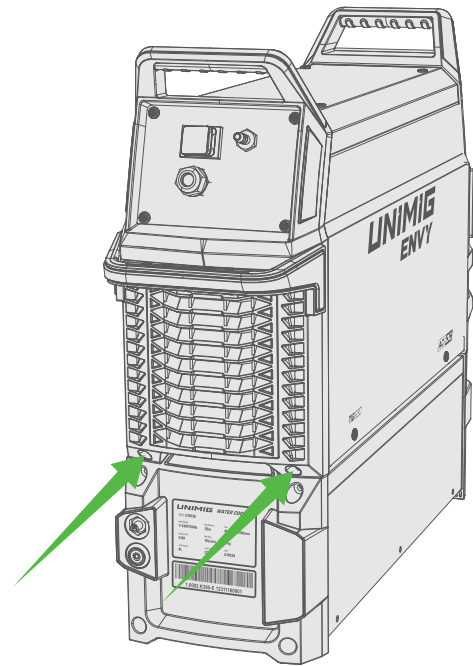
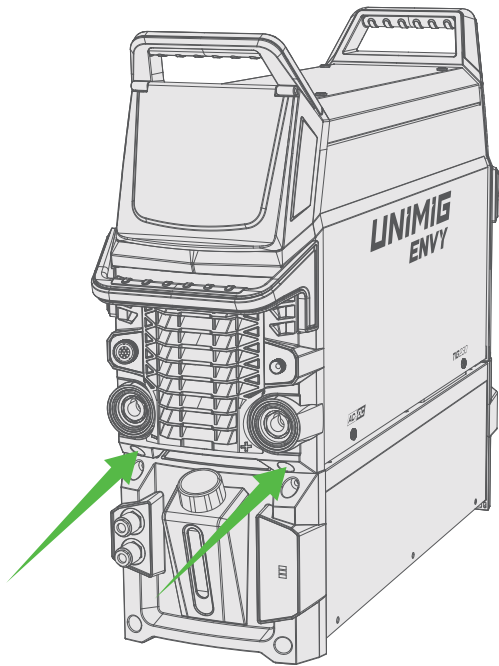

6.2 Installing Equipment on the Trolley (optional)

Assemble the welding trolley according to the instructions provided with it.

6.2.1 Installing the Machine Only

1. Attach the two L shaped mounting brackets onto the trolley.

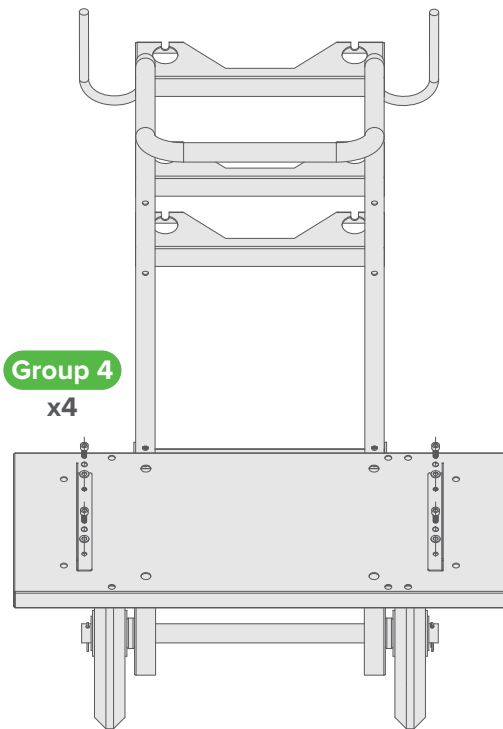

2. Place the machine on the trolley, so that the feet sit over the mounting brackets, and screw it in via the mounting points.

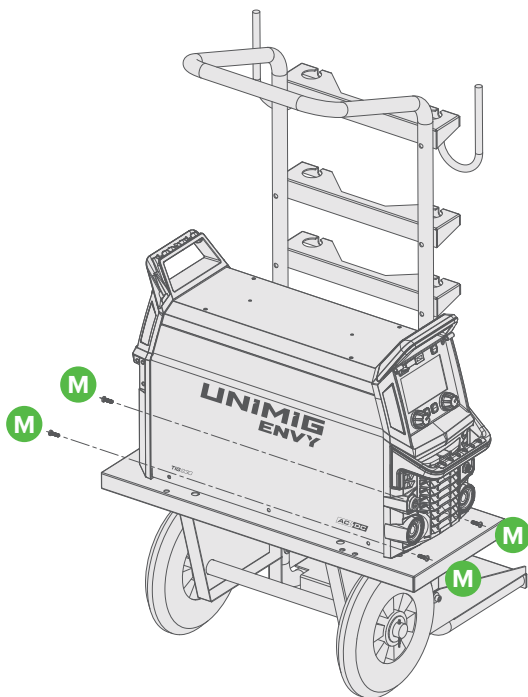

6.2.2 Installing the Water Cooler & Machine

1. Attach the two feet mounts to the bottom of the water cooler. It is recommended to do this before connecting the machine.

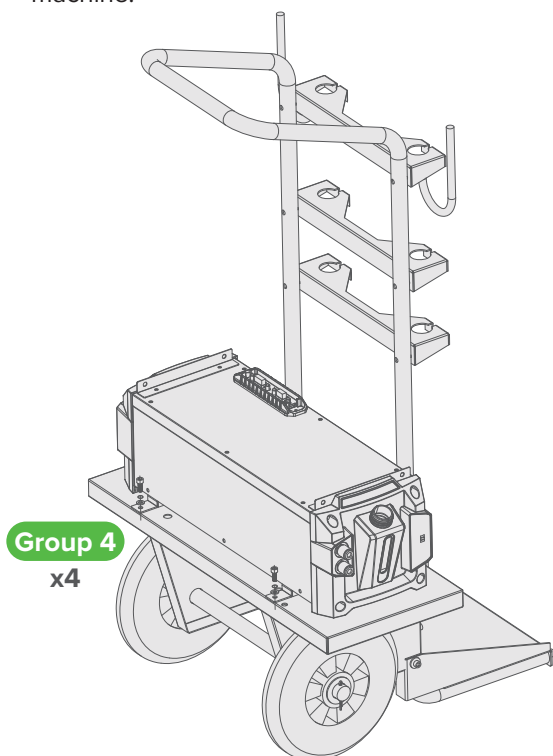

2. Place the water cooler and machine on the trolley and screw it in via the mounting points.

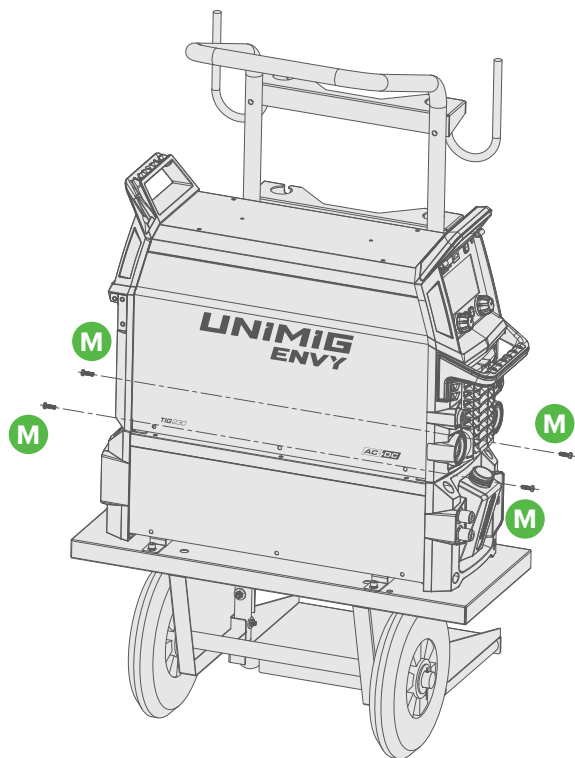

6.3 Assembling a T2 TIG Torch

1. Place the head gasket onto the torch head.

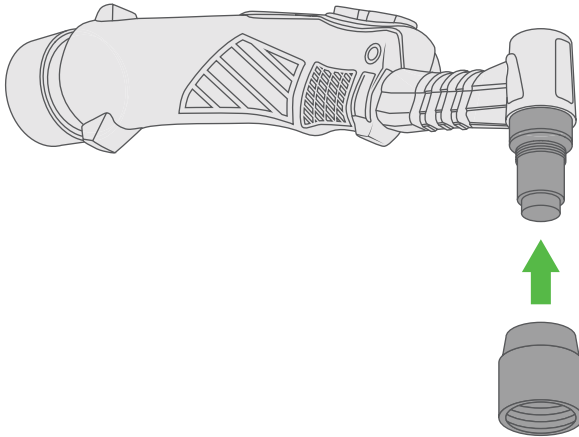

2. Screw the heat zone isolator onto the torch head. Fasten securely.

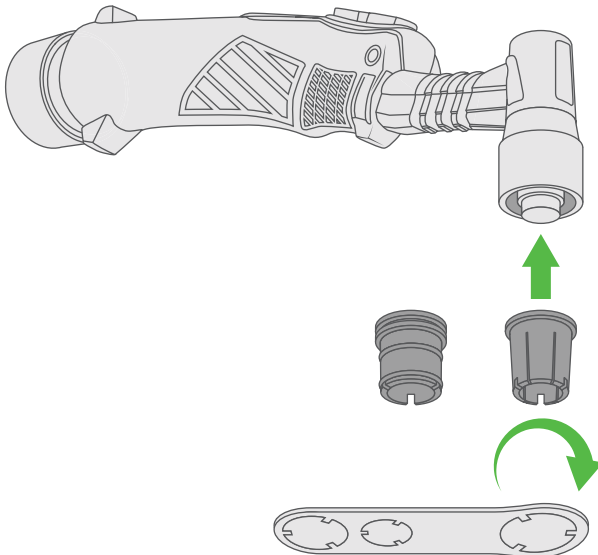

3. Insert the collet body into the torch head. Align the groove with the inside of the torch head.

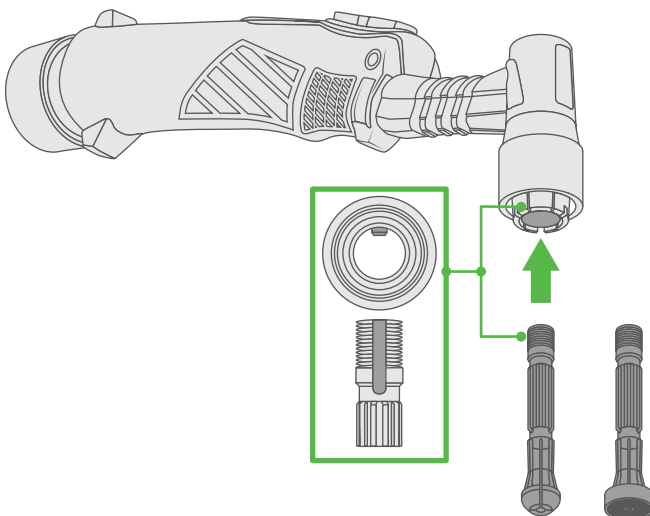

4. Screw the back cap onto the torch head, don't tighten completely.

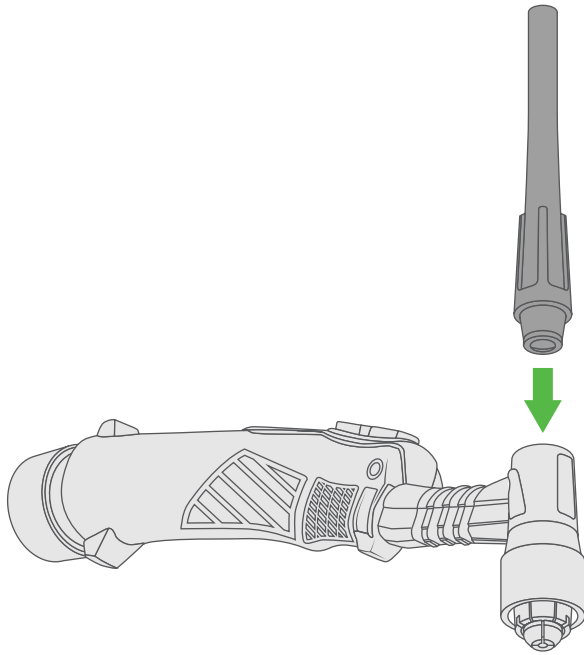

5. Insert the tungsten electrode into the collet body.

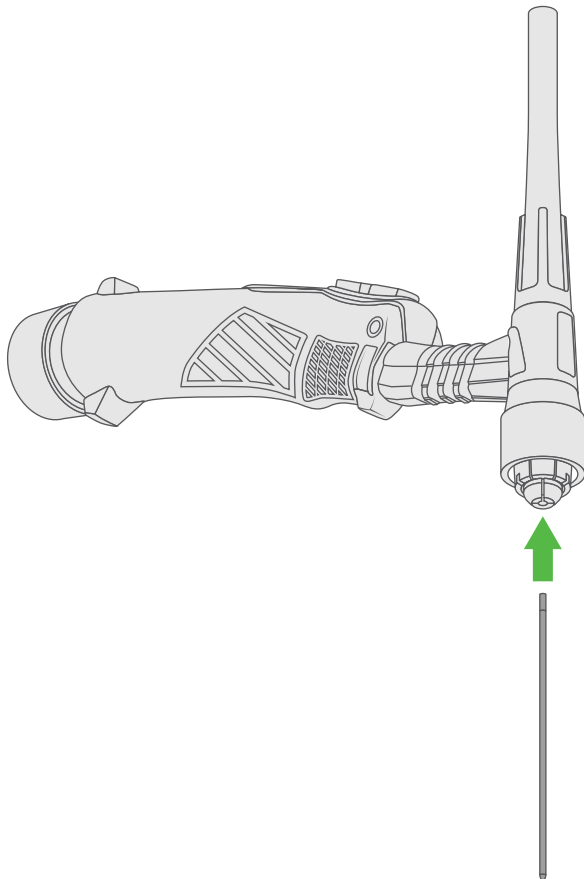

6. Slide on the ceramic cup over the collet body. Twisting the ceramic cup can aid in securing the consumables in place.

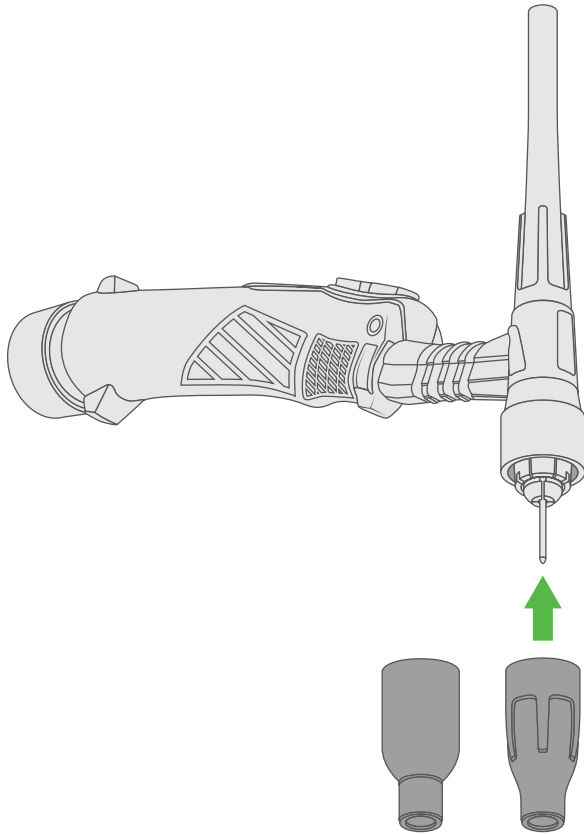

7. Adjust the tungsten to the desired length, then tighten the back cap.

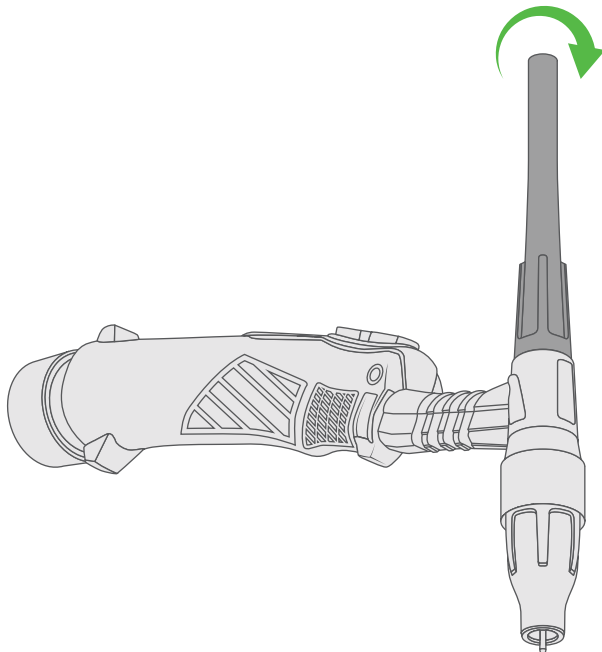

6.4 Connecting the TIG Torch

6.4.1 Air Cooled Torch

1. Assemble the TIG torch.
2. Connect the TIG torch to the negative (-) dinse connection, and twist to lock it in place.
3. Plug the torch connector into the pin socket.
4. Plug the gas connector into the gas outlet.

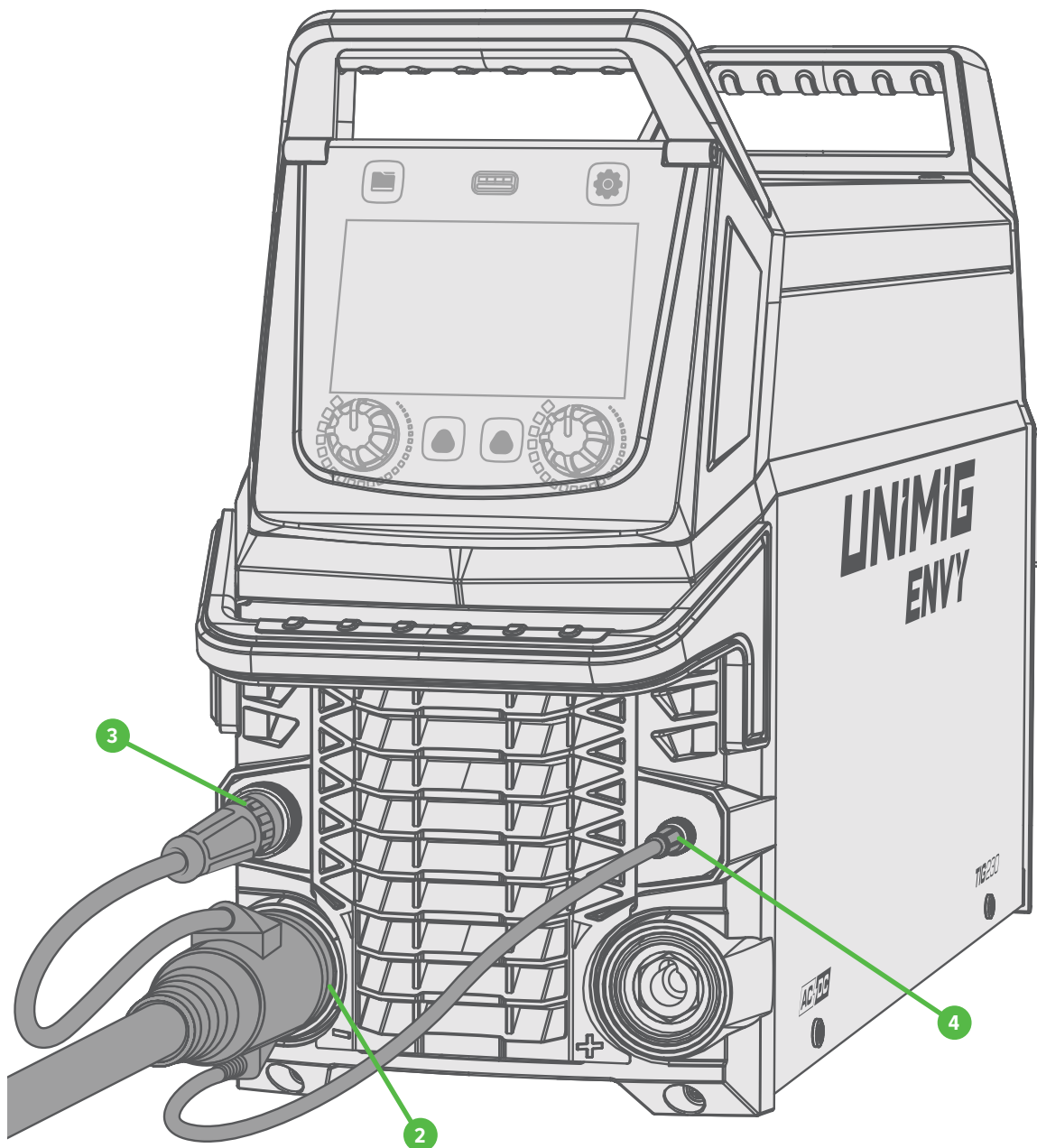

6.4.2 Water Cooled Torch

1. Assemble the TIG torch.
2. Connect the TIG torch to the negative (-) dinse connection, and twist to lock it in place.
3. Plug the red coolant return cable into the red output connection and the blue coolant supply cable into the blue input connection.
4. Plug the torch connector into the pin socket.
5. Plug the gas connector into the gas outlet.

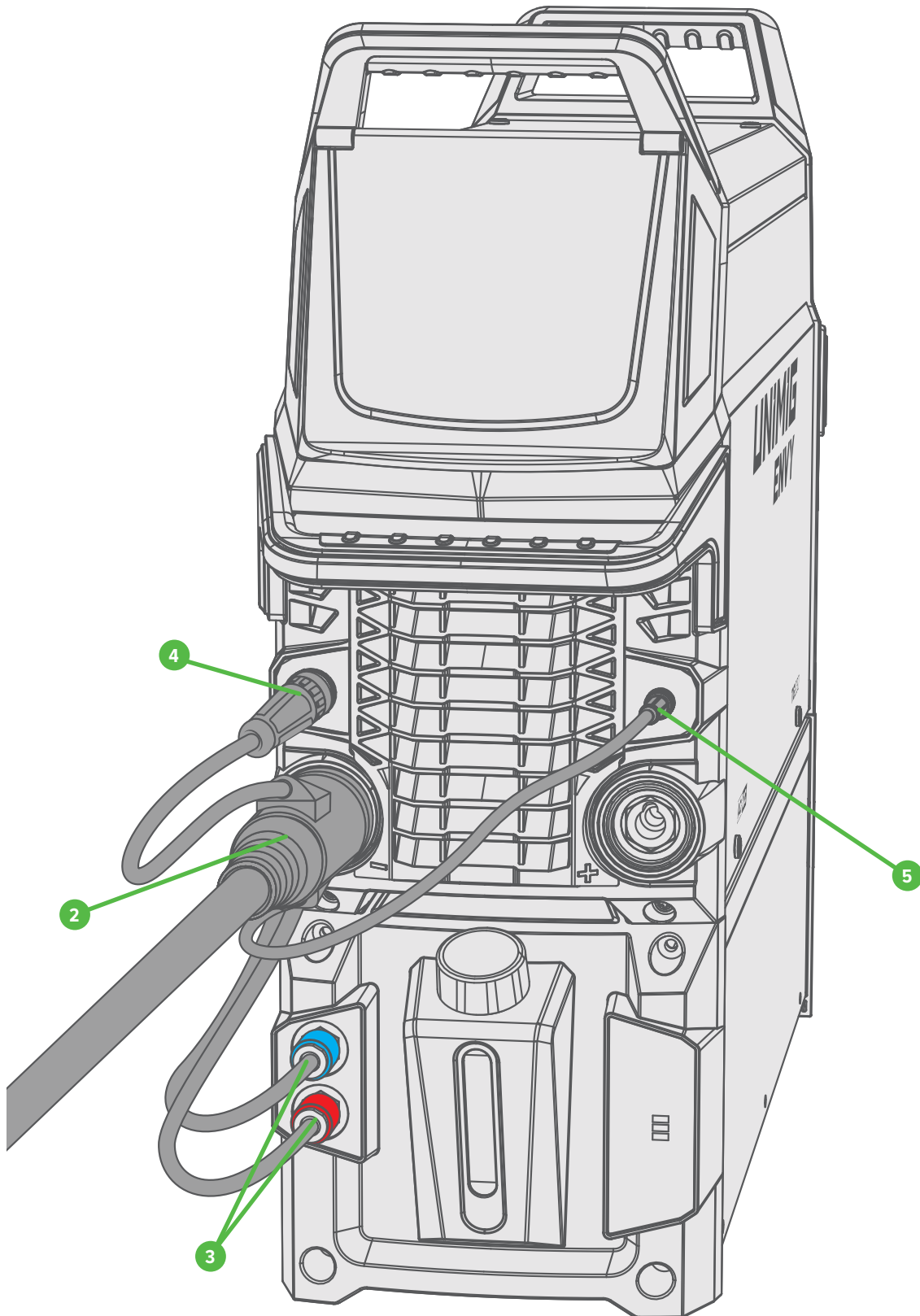

6.5 Connecting the MMA Electrode Holder

DCEN

For DC- electrodes, connect the electrode holder to the negative (-) dinse connection, and twist to lock it in place.

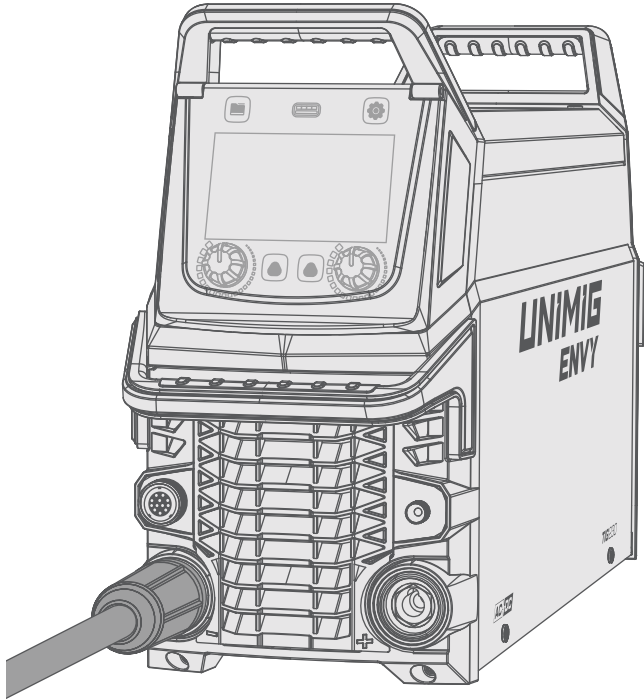

DCEP

For DC+ electrodes, connect the electrode holder to the positive (+) dinse connection, and twist to lock it in place.

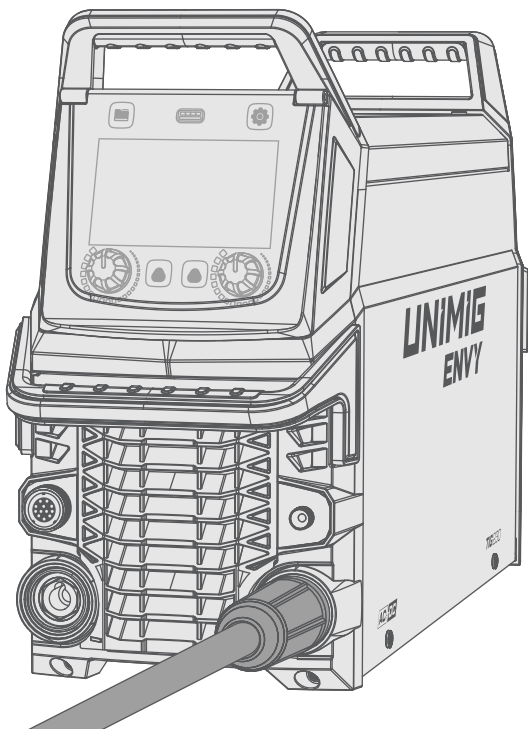

6.6 Connecting the Earth Clamp

TIG

For TIG, connect the earth clamp to the positive (+) dinse connection, and twist to lock it in place.

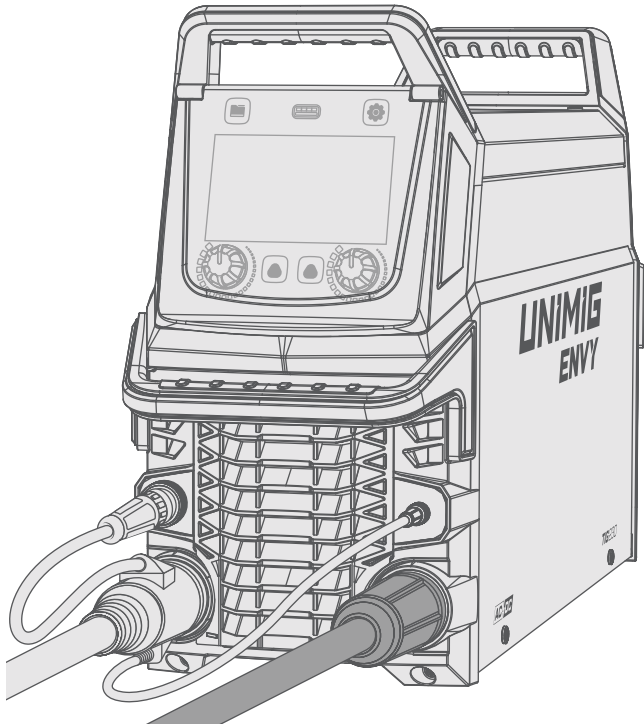

MMA

DCEN

For DC- MMA electrodes, connect the earth clamp to the positive (+) dinse connection, and twist to lock it in place.

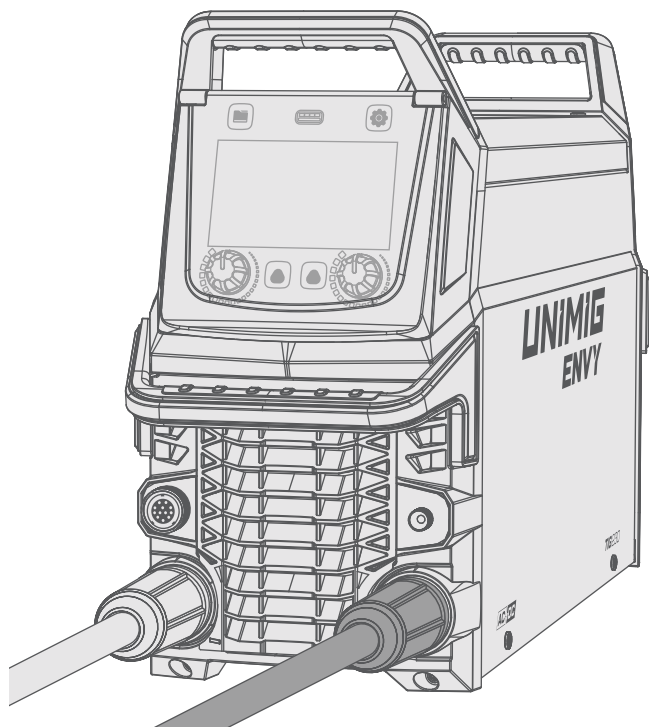

DCEP

For DC+ MMA electrodes, connect the earth clamp to the negative (-) dinse connection, and twist to lock it in place.

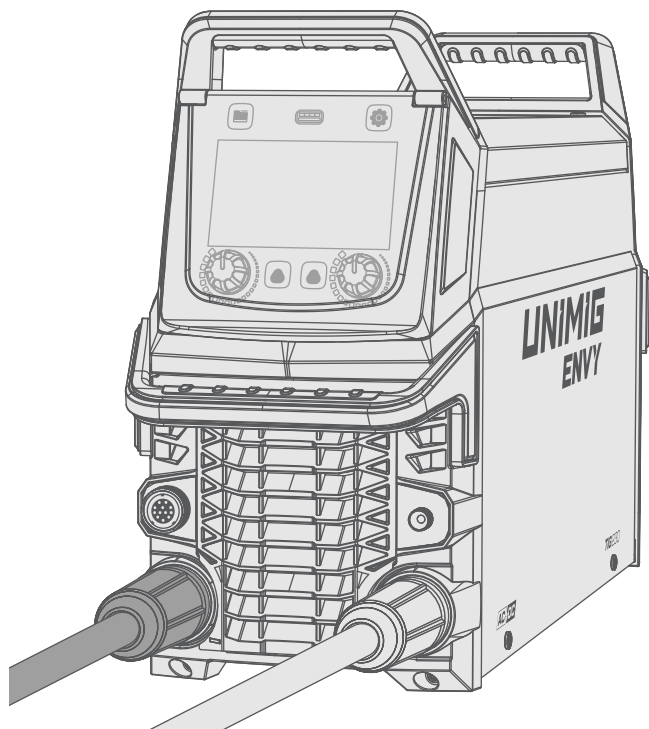

6.7 Connecting a Foot Pedal

6.7.1 Wired Foot Pedal

1. If connected, disconnect the TIG torch connector cable from the pin socket.
2. Connect the foot pedal connector cable into the pin socket.
3. Place the machine into remote mode. To do this:
Enter the Settings menu and select **Remote Pedal** under the **Remote Mode** option (See "7.8 Settings Menu" on page 48).

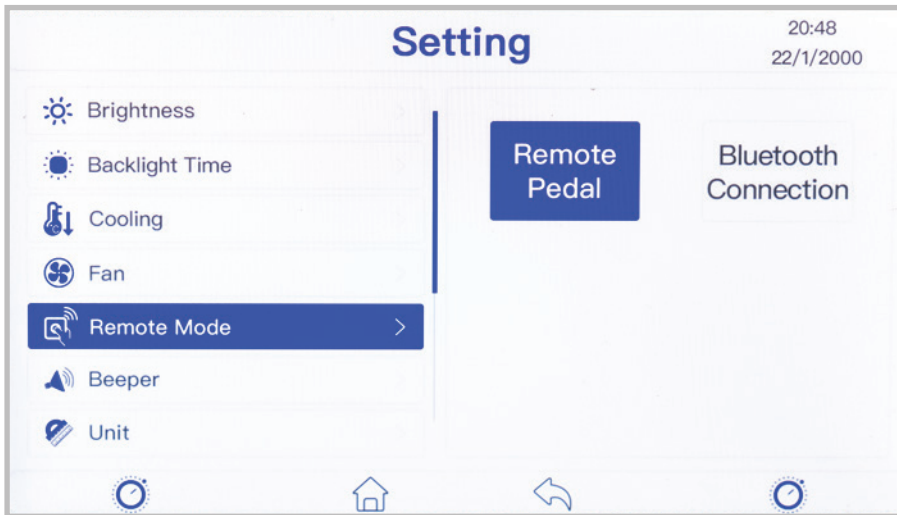

6.7.2 Wireless Foot Pedal

1. Take the foot pedal battery cover off. Install new batteries (3 x AA) and put the cover back on the foot pedal.

Refer to the (+) and (-) signs on the battery holder for the correct positioning of batteries.

2. Turn the foot pedal to ON.
3. Press the pedal down and release it to have the pedal enter pairing mode. The pedal will beep while it is in pairing mode.
4. On the machine, enter the **Remote Mode** screen in the Settings menu and select **Remote Pedal** and then **Bluetooth Connection**.

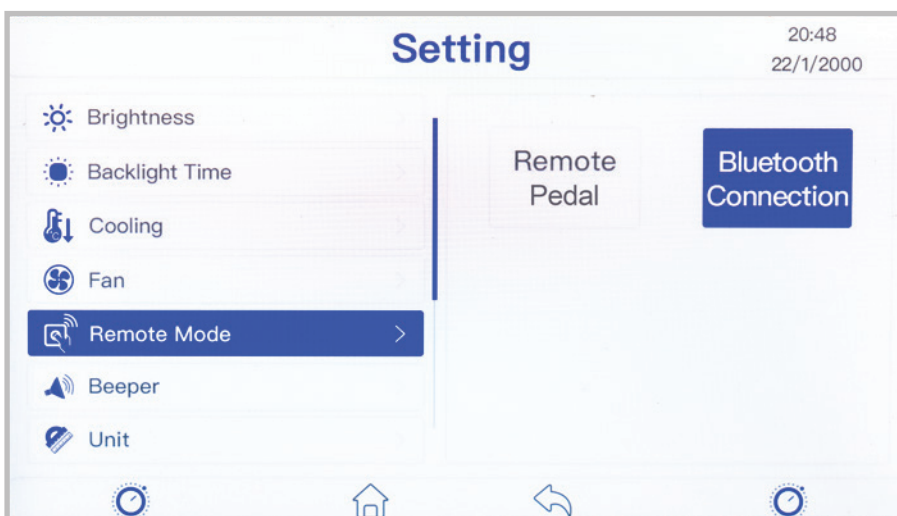

- The machine will search for available devices. Press the right control knob to select the pedal when it appears. The foot pedal will beep quickly three times when it pairs, and the bluetooth screen will close to the main **Remote Mode** options.

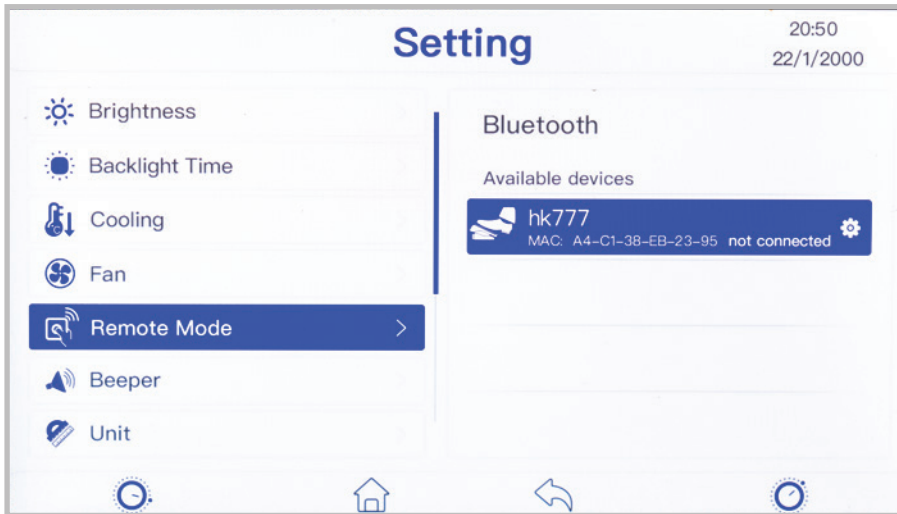

- Entering the **Bluetooth Connection** option again will display the connected foot pedal and the adjustable settings for this device (See "7.8 Settings Menu" on page 48).

i When using a foot pedal while pulse welding, the pedal will adjust the peak amperage as a percentage.

For example, if the peak amperage is set to 100A and the base amperage to 30A, fully pressing the pedal will give a peak amperage of 100A. Pressing the foot pedal halfway will reduce the peak amperage to 50% of the set peak, in this case 50A, and maintain the base amperage of 30A.

6.8 Installing the Gas Bottle & Testing the Gas Flow

⚠ Handle the gas bottle with care. There is a risk of injury if the gas bottle or the bottle valve is damaged.

ⓘ If you have a new gas bottle, remove the insert tab from the valve.

1. Securely fasten the gas cylinder to a wall or stationary support so it can't fall.
2. Stand to the side and open the gas bottle valve or safety lock quickly to blow away any dirt or dust from it before closing it again.
3. Screw in your regulator or flowmeter so that the face of the gauge is vertical, and then tighten it with a wrench.
4. Connect the gas hose to the regulator/flowmeter outlet connection and the gas fitting on the back of the machine.
5. Open the gas bottle valve or safety lock and adjust your flow rate using the gas flow regulation screw.

ⓘ When turning gas flow regulation screw, do it slowly. Cranking the screw can damage the regulator/flowmeter and cause gas leakage.

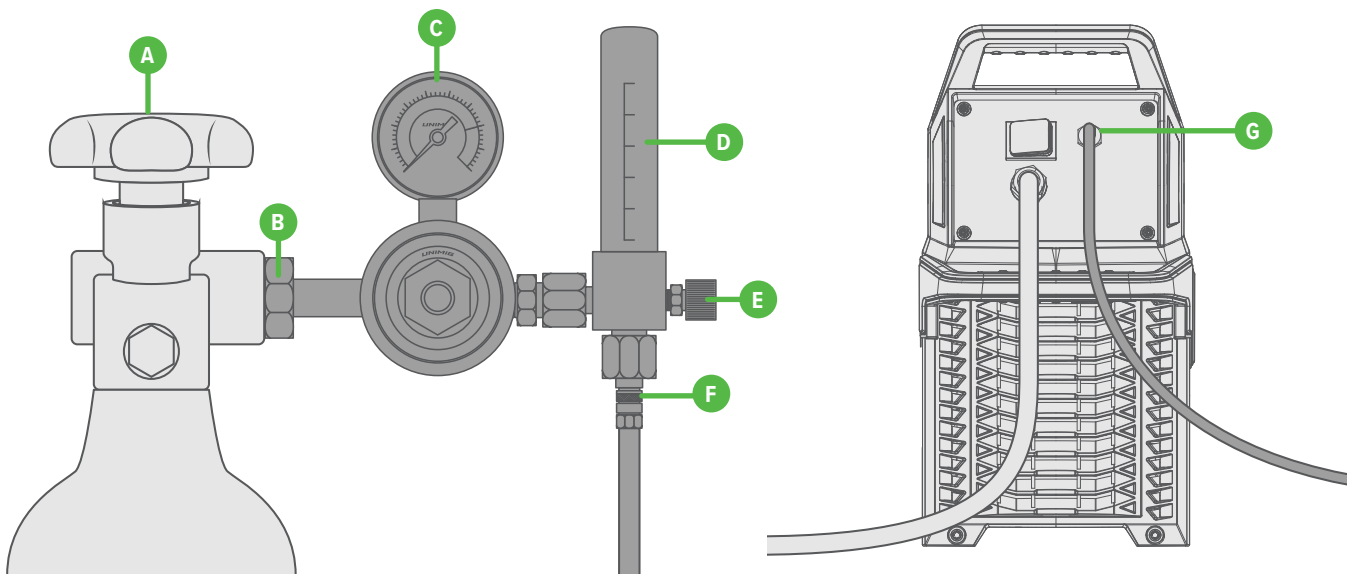

- A.** Gas bottle valve
- B.** Inlet connection (AS2473 Type 10)
- C.** Gas bottle contents indicator
- D.** Gas flow meter
- E.** Gas flow regulation screw
- F.** Outlet connection (5/8" UNF Male RH)
- G.** Machine gas fitting (6mm quick-connect barb)

Recommended Gas Flow Rates

Gas Mixture	TIG
Argon	5-15L/min
Helium	5-15L/min

The gas flow rates mentioned are intended as guidelines only. Actual gas flow rates may vary based on the specific gas cup selected.

6.8.1 Testing the Gas Flow

i Testing the gas flow via an external gas test is recommended as the gas solenoid in the machine can cause a small loss of gas as it travels through the machine internals. A gas test lets you check the difference in the flow rate selected on the regulator/flowmeter and the flow exiting the torch.

1. Open the gas bottle valve.
2. Connect a gas flow tester to the end of the torch and start the gas flow by pressing the torch trigger.
3. Check the gas flow tester is reading the gas flow rate selected.

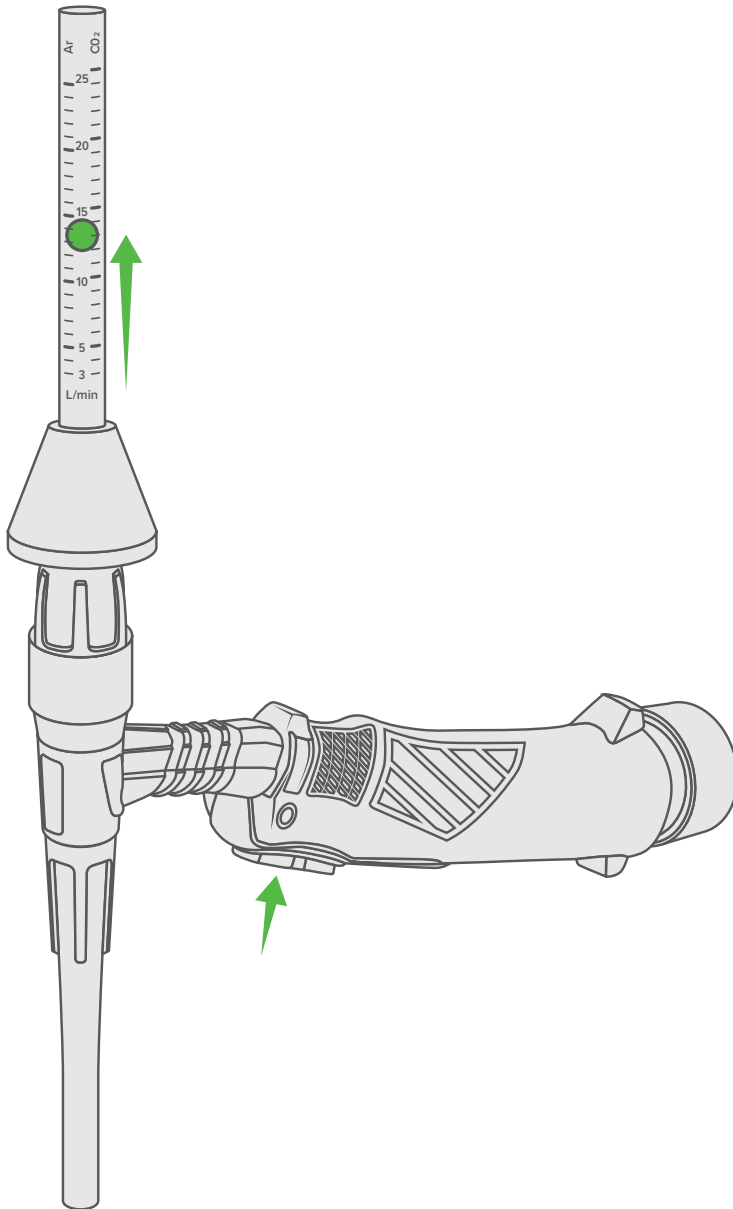

6.9 Regulator Safety & Operation

⚠ This equipment is designed for use with welding grade (inert) shielding gases only.

This regulator/flowmeter is designed to reduce and control the flow of high-pressure gas from a cylinder down to a level that is suitable for the equipment it's supplying. Make sure the pressure regulator is designed for use with high pressure gas cylinders and that the connection nut thread matches the cylinder valve outlet.

Misuse of the equipment can lead to dangerous situations, which could result in accidents. It is crucial for users to avoid such scenarios. Prior to operating or handling the equipment, it is imperative to understand and adhere to the safety guidelines provided in this manual.

The following instructions detail specific practices for using regulators/flowmeters:

1. Do not expose the regulator/flowmeter to inlet pressures exceeding its maximum specified limit.
2. Do not pressurise a regulator/flowmeter if it exhibits any signs of damage, loose components, or appears to be in poor condition.
3. Do not attempt to loosen or detach any parts from the regulator/flowmeter without first ensuring the gas pressure has been fully released. Pressurised gas can forcefully eject a dislodged part, creating a hazard.
4. Do not open the cylinder unless a pressure regulator/flowmeter has been fitted.
5. An opened valve should never be fully opened until resistance is encountered, but should be turned back at least half a turn to prevent the valve from becoming stuck in the open position. This can occur if the valve is left open for long periods of time.
6. Ensure the cylinder valve is fully closed and any gas within the regulator/flowmeter's high and low-pressure chambers has been vented before removing the device from a cylinder.
7. Do not use the regulator/flowmeter as a shut-off valve. To prevent gas flow when downstream equipment is not in use for an extended period, turn off the gas at the source and vent it from the system.
8. Open the cylinder valve slowly and make sure to close it after finishing. When you shut the valve, turn it just enough to stop the gas completely. Do not over tighten.
9. Do not attempt to repair or modify the regulator.

User Responsibilities

This equipment will perform safely and reliably only if it is installed, operated, maintained, and repaired strictly according to the provided instructions. Regular checks are essential to ensure its ongoing safe and reliable operation.

Any necessary repairs, replacements, or adjustments must be carried out promptly. Do not use equipment that is defective. Immediate replacement is required for parts that are broken, missing, visibly worn, deformed, or contaminated.

Typically, the user will bear exclusive responsibility for any malfunctions resulting from improper usage, inadequate maintenance, or repairs conducted by individuals other than certified repair technicians.

Installation

Before connecting a pressure regulator to a full cylinder always screw out (anticlockwise) the regulation screw. This ensures that there will be no gas flow through the regulator upon initially opening the cylinder valve, reducing strain on the regulator's internal safety component (known as a diaphragm) and increasing the lifespan of the regulator.

Remove the plastic dust seal from the cylinder valve. Before attaching the regulator/flowmeter, ensure the cylinder valve outlet is free from any impurities that could block the orifices or damage the seats. Briefly open then immediately close the valve, directing the outlet away from both people and any potential sources of ignition. Clean the outlet with a lint-free cloth.

If grit, dirt, oil or dirty water enters the cylinder valve outlet, this may cause damage to the valve internals and result in leakage.

⚠ Match the regulator/flowmeter to the cylinder. Never connect a regulator/flowmeter designed for a particular gas or gases to a cylinder containing any other gas.

To attach the regulator/flowmeter:

1. Attach the inlet of the regulator/flowmeter to the cylinder, securing it snugly with a proper wrench, but avoid over-tightening. Regulator connections can be fully threaded in by hand and then only require a fraction of a turn to achieve a gas tight seal.
2. Secure the outlet hose tightly, then connect any downstream equipment.
3. For downstream equipment that is sensitive, consider the installation of an additional safety device if the regulator/flowmeter does not include a built-in pressure relief feature.

Operation

Once the regulator/flowmeter is connected to the cylinder with the regulation screw completely disengaged, follow these steps to pressurise:

1. Position yourself to the side of the regulator/flowmeter and gradually open the cylinder valve. Rapid opening can cause a sudden pressure increase, potentially damaging the internal components of the regulator/flowmeter.
2. Ensure all valves on the downstream equipment are closed, then set the regulator/flowmeter to the desired working pressure.

i It's advisable to perform a leak test at the connection points of the regulator/flowmeter using an appropriate leak detection solution or soapy water.

3. Purge any air or non-essential welding grade shielding gas from the system attached to the regulator/flowmeter by briefly opening and then closing each control valve. The duration of the purge process could last as long or longer than ten seconds, depending on both the length and diameter of the hose being cleared.

To adjust the operational flow rate of the regulator/flowmeter:

1. Slowly turn the regulator/flowmeter's regulation screw (clockwise) until the outlet gauge shows the desired flow rate.

i It might be necessary to re-evaluate the flow rate of the shielding gas through the regulator/flowmeter after completing an initial series of welds, as back pressure within the shielding gas hose assembly can affect readings.

2. To decrease the flow rate, first ensure the welding-grade shielding gas is safely vented from the regulator/flowmeter by opening the downstream valve. Direct the released gas to a well-ventilated area, away from any potential sources of ignition. Then, adjust the screw (anticlockwise) until the gauge reflects the desired flow rate. Finally, shut the downstream valve.

Shutdown

Always close the cylinder valve when the regulator/flowmeter is not in use. For shutdowns lasting longer than 30 minutes, follow these steps:

1. Close the gas cylinder or upstream valve.
2. Open downstream equipment valves to purge the lines, directing the gas to a well-ventilated area, and away from ignition sources.
3. Once the gas is fully vented, turn the regulation screw to its closed position and close the valves on the downstream equipment.
4. Prior to moving cylinders that are not fixed on a specifically designed trolley, detach the regulators/flowmeters.

6.10 Installing the Gas Bottle on the Trolley

1. Move the gas bottle on to the trolley's gas bottle rack.

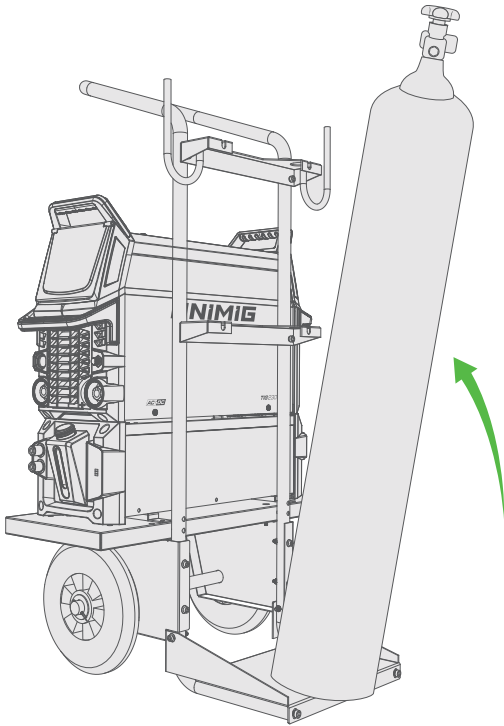

2. Secure the gas bottle in place with the chains. Use the dedicated fixing points on the trolley.

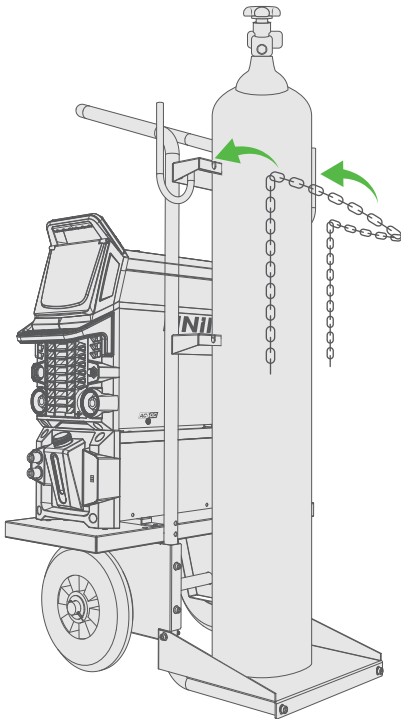

⚠ There is a risk of accident if the gas cylinder is improperly or inadequately secured which could result in severe injury. The cylinder must be secured with at least two of the chains.

7. Operation

7.1 Preparing for Operation

Before using the equipment, ensure that all the necessary installation actions have been completed according to your equipment setup and instructions.

i Industry standards typically dictate the minimum and maximum welding capacity and are influenced by practical considerations for both single-pass and multi-pass welds to secure the best possible quality. The material thicknesses indicated on this machine are subject to these standards and best practices for the weld being performed.

i Always check before use that the torch cable, shielding gas hose, earth cable/clamp and power cable are in serviceable condition. Ensure that the connectors are correctly fastened. Loose connectors can impair welding performance and damage connectors.

Connect the plug into the mains socket, then switch the machine ON.

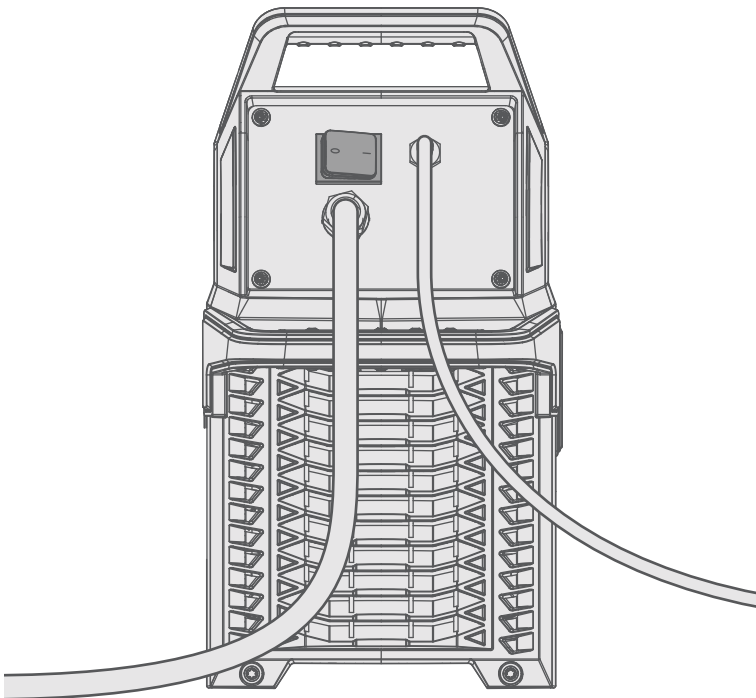

7.2 Control Panel Layout & Operation

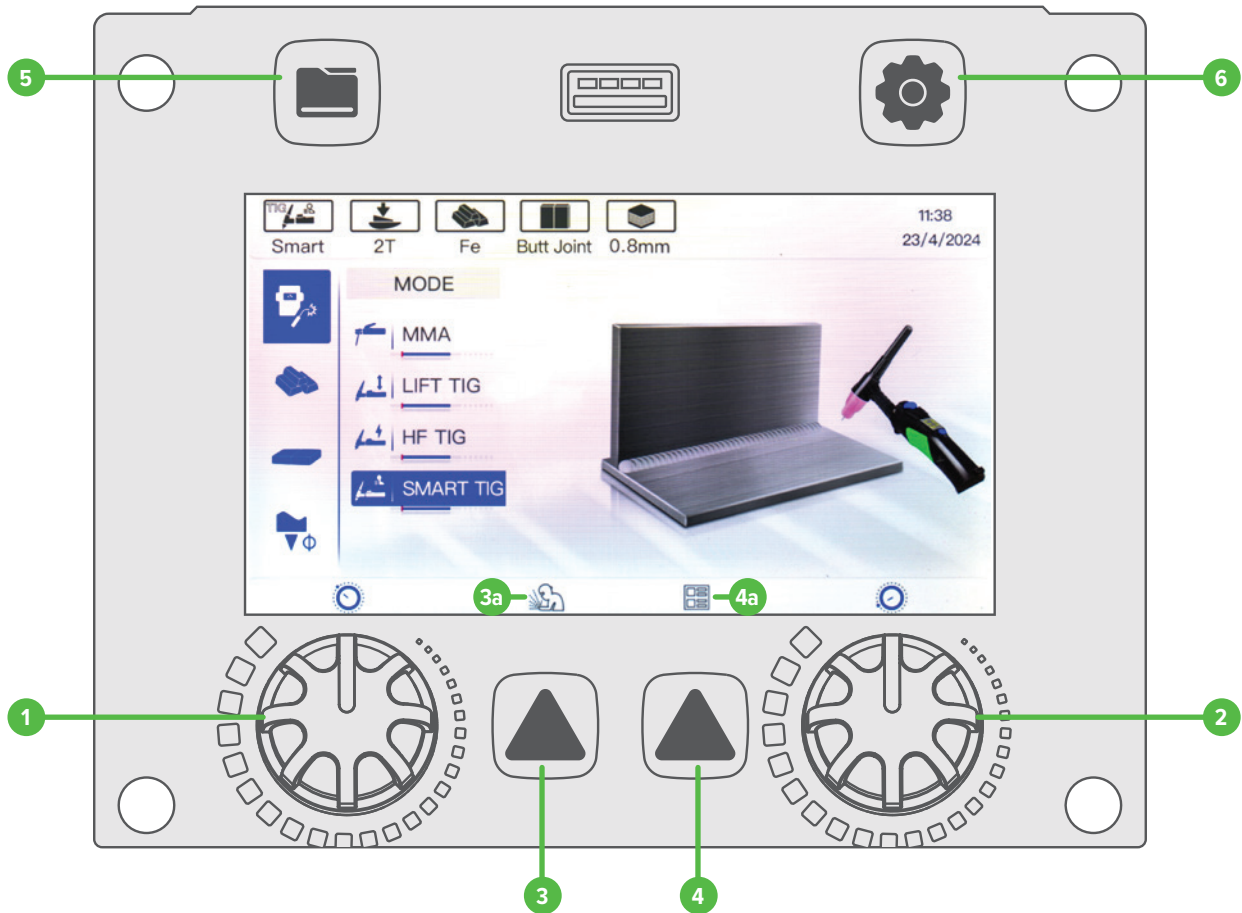

1. Left control knob

- Turn** this knob for digital screen navigation and cycling through menu options. If a menu option is active, turning this knob will adjust the item value.
- Press** this knob to confirm actions between the weld screen and weld menu parameters. Pressing this knob also cycles through weld cycle parameters.

2. Right control knob

- Turn** this knob for digital screen navigation and cycling through menu options. If a menu option is active, turning this knob will adjust the item value.
- Press** this knob to confirm actions between the weld screen and weld menu parameters. Pressing this knob also cycles through weld cycle parameters.

3. Left select button

Press the left select button to select the action in **3a**.

4. Right select button

Press the right select button to select the action in **4a**.

5. Job button

Press the Job button to open the Job Menu.

6. Setting button

Press the Settings button to open the Settings Menu.

7.3 MMA Mode



1. From the home screen, **press** the left control knob to select **MMA Mode**.
2. **Turn** the left control knob to adjust the Current.
3. **Press** the right control knob to cycle between Pulse, Wave and VRD. **Turn** the right control knob to select a parameter.
4. **Press** the right select button to enter the advanced parameters screen.
5. **Turn** the left control knob to scroll through the parameters. **Turn** the right control knob to adjust the parameters.
6. **Press** the right select button again to return to the main parameters screen.
7. **Press** the left select button to return to the home screen.

7.3.1 Welding Parameters

Parameter	Value	Description
Current	10A - 200A	Sets the maximum current level while welding.
Pulse	Off / On	Alternates the welding current between a high and low value to aid in heat control and improve weld quality.
Wave	DC / AC Square	The waveform determines whether you're welding in DC mode or AC Square mode.
VRD	Off / On	The VRD is a safety device that reduces the open-circuit voltage of a welding machine. This minimises the risk of electric shock, especially in hazardous areas like enclosed or moist environments.

7.3.2 Advanced Welding Parameters

Parameter	Value	Description
Hot Start	0% - 100%	Hot Start boosts the initial welding current for a short duration to ensure a reliable arc start.
Hot Start Time	0.5s - 5s	The time that the Hot Start current runs for.
Peak Amp	10A - 200A	The maximum current level during the weld. This also sets the peak in the pulse cycle.
Base Amp	10A - 200A	The lower current level in the pulse cycle.
Arc Force	0% - 100%	The level of current boost when the machine senses voltage drops, improving arc stability and preventing electrode sticking.
Frequency	0.5PPS - 400PPS	The number of pulse cycles every second.
Pulse Width	5% - 95%	Sets the time the arc stays at its peak amperage during the pulse cycle.

i The settings available in the advanced welding parameters screen will depend on the standard welding parameters selected.

7.4 Lift TIG Mode



1. From the home screen, **Press** the left control knob to select **Lift TIG Mode**.
2. **Press** the left control knob to cycle between Current and Thickness. **Turn** the left control knob to adjust the parameters.
3. **Press** the right control knob to cycle between Pulse, Trigger and Wave. **Turn** the right control knob to select a parameter.
4. **Press** the right select button to enter the advanced parameters screen.
5. **Turn** the left control knob to scroll through the parameters. **Turn** the right control knob to adjust the parameters.
6. **Press** the right select button again to return to the main parameters screen.
7. **Press** the left select button to return to the home screen.

7.4.1 Welding Parameters

Parameter	Value	Description
Current	2A - 230A	Sets the maximum current level while welding.
Thickness	1.0mm - 10mm	Sets the workpiece thickness.
Pulse	Off / On	Alternates the welding current between a high and low value to aid in heat control and improve weld quality.
Trigger	2T / 4T	Switch between torch trigger modes. Trigger Mode 2T Initiates welding when the torch trigger is pressed and stops when released. Trigger Mode 4T Press the torch trigger once to start welding and release it. Press again to stop the weld. This mode is useful for longer welds and reducing hand fatigue.
Wave	<ul style="list-style-type: none"> • DC • DC Square • DC Sine • DC Triangle • AC Square • AC Sine • AC Triangle • AC Square Sine • AC Square Triangle • AC Sine Square • AC Sine Triangle • AC Triangle Square • AC Triangle Sine 	The waveform determines whether you're welding in DC mode or AC mode. Select your desired DC or AC waveform.

7.4.2 Advanced Welding Parameters

Parameter	Value	Description
Pre-Gas	0s - 20s	Sets the duration of shielding gas released before the arc ignites.
Start Amp	2A - 230A	Sets the amperage at the beginning of the welding process.
Up Slope	0s - 20s	Sets the time the welding current takes to rise from the Start Amp to the main welding current.
Peak Amp	2A - 230A	The maximum current level during the weld. This also sets the peak in the pulse cycle.
Base Amp	2A - 230A	Sets the lower current level in the pulse cycle.
Pulse Width	5% - 95%	Sets the time the arc stays at its peak amperage during the pulse cycle.
Frequency	0.5PPS - 999PPS	Sets the number of pulse cycles every second.
Down Slope	0s - 20s	Sets the time the welding current takes to decrease from the main welding current to the End Amp.
End Amp	2A - 230A	Sets the final welding current value before the arc stops.
Post-Gas	0s - 20s	Sets the duration of shielding gas released after the welding arc stops.
Diameter	1.6mm - 3.2mm	Sets the tungsten electrode diameter.
Balance	15% - 50%	Sets the ratio of positive to negative current in the AC cycle.
AC Frequency	50Hz - 250Hz	Sets the number of AC cycles in one second.
Mixed AC/DC	0% - 80%	Sets the percentage of AC in the mixed TIG cycle.
Amplitude Control	-70% - 70%	Sets the percentage of the AC waveform that is on the negative side for a more penetrative weld.
Steady Arc	0A - 50A	Sets the amount of adjustment on the welding current based on the arc voltage. When the voltage goes down, the amperage will go up, and vice versa, to give a consistent weld puddle, a sharper arc and a constant heat input.
Min Amp	2A - 230A	Sets the minimum amperage of the machine. Only available when in Remote Mode.
Purge	N/A	Purge your gas lines by pressing and holding/clicking on and off.



The settings available in the advanced welding parameters screen will depend on the standard welding parameters selected.

7.5 HF TIG Mode



1. From the home screen, **press** the left control knob to select **HF TIG Mode**.
2. **Press** the left control knob to cycle between Current and Thickness. **Turn** the left control knob to adjust the parameters.
3. **Press** the right control knob to cycle between Pulse, Trigger and Wave. **Turn** the right control knob to select a parameter.
4. **Press** the right select button to enter the advanced parameters screen.
5. **Turn** the left control knob to scroll through the parameters. **Turn** the right control knob to adjust the parameters.
6. **Press** the right select button again to return to the main parameters screen.
7. **Press** the left select button to return to the home screen.

7.5.1 Welding Parameters

Parameter	Value	Description
Current	2A - 230A	Sets the maximum current level while welding.
Thickness	1.0mm - 10mm	Sets the workpiece thickness.
Pulse	Off / On	Alternates the welding current between a high and low value to aid in heat control and improve weld quality.
Trigger	2T / 4T / HCT / SPOT	Switch between torch trigger modes: Trigger Mode 2T Initiates welding when the torch trigger is pressed and stops when released. Trigger Mode 4T Press the torch trigger once to start welding and release it. Press again to stop the weld. This mode is useful for longer welds and reducing hand fatigue. Trigger Mode HCT Heat Control Trigger (HCT) lets you set a base current which you can switch to at any time during a weld by pressing the trigger button. HCT is great for manual heat input control as you go. Spot Mode Spot mode provides precision in creating timed weld spots with controlled intervals and counts. It's ideal for consistent tacking or producing uniform joints across materials.

Parameter	Value	Description
Wave	<ul style="list-style-type: none"> • DC • DC Square • DC Sine • DC Triangle • AC Square • AC Sine • AC Triangle • AC Square Sine • AC Square Triangle • AC Sine Square • AC Sine Triangle • AC Triangle Square • AC Triangle Sine 	The waveform determines whether you're welding in DC mode or AC mode. Select your desired DC or AC waveform.

7.5.2 Advanced Welding Parameters

Parameter	Value	Description
Pre-Gas	0s - 20s	Sets the duration of shielding gas released before the arc ignites.
Start Amp	2A - 230A	Sets the amperage at the beginning of the welding process.
Up Slope	0s - 20s	Sets the time the welding current takes to rise from the Start Amp to the main welding current.
Peak Amp	2A - 230A	The maximum current level during the weld. This also sets the peak in the pulse cycle.
Base Amp	2A - 230A	Sets the lower current level in the pulse cycle.
Pulse Width	5% - 95%	Sets the time the arc stays at its peak amperage during the pulse cycle.
Frequency	0.5PPS - 999PPS	Sets the number of pulse cycles every second.
Down Slope	0s - 20s	Sets the time the welding current takes to decrease from the main welding current to the End Amp.
End Amp	2A - 230A	Sets the final welding current value before the arc stops.
Post-Gas	0s - 20s	Sets the duration of shielding gas released after the welding arc stops.
Diameter	1.6mm - 3.2mm	Sets the tungsten electrode diameter.
Balance	15% - 50%	Sets the ratio of positive to negative current in the AC cycle.
AC Frequency	50Hz - 250Hz	Sets the number of AC cycles in one second.
Cap Shaping	Off / On	Automatically balls the tungsten end, eliminating manual preparation for enhanced efficiency.
Mixed AC/DC	0% - 80%	Sets the percentage of AC in the mixed TIG cycle.
Amplitude Control	-70% - 70%	Sets the percentage of the AC waveform that is on the negative side for a more penetrative weld.
Speed Start	0s - 60s	Speeds up the formation of the weld puddle by applying a synergic pulse program to the beginning of the weld. Sets how long this initial program runs. TackPlus is unavailable while a Speed Start value is set.
Steady Arc	0A - 50A	Sets the amount of adjustment on the welding current based on the arc voltage. When the voltage goes down, the amperage will go up, and vice versa, to give a consistent weld puddle, a sharper arc and a constant heat input. TackPlus is unavailable while a Steady Arc value is set.
TackPlus	0Hz - 6Hz	Create evenly spaced and sized fusion tack welds along a joint with minimal heat input. Sets the frequency of the tack welds. Speed Start and Steady Arc are unavailable while a TackPlus value is set.
Spot Time	0.1s - 10s	Sets the duration for each spot weld.
Min Amp	2A - 230A	Sets the minimum amperage of the machine. Only available when in Remote Mode.
Purge	N/A	Purge your gas lines by pressing and holding/clicking on and off.

 **The settings available in the advanced welding parameters screen will depend on the standard welding parameters selected.**

7.6 Smart TIG Mode



1. From the home screen, **Press** the left control knob to select **Smart TIG Mode**.
2. **Turn** the left control knob to choose a material type and **press** to select it.
3. **Turn** the left control knob to choose a joint type and **press** to select it.
4. **Turn** the left control knob to choose a material thickness and **press** to select it.
5. **Press** the right select button at any of these steps to return back to the previous screen.
6. **Press** the left control knob to cycle between Current and Thickness. **Turn** the left control knob to adjust the parameters.
7. **Press** the right control knob to cycle between Pulse, Trigger and Wave. **Turn** the right control knob to select a parameter.
8. **Press** the right select button to enter the advanced parameters screen.
9. **Turn** the left control knob to scroll through the parameters. **Turn** the right control knob to adjust the parameters.
10. **Press** the right select button again to return to the main parameters screen.
11. **Press** the left select button to return to the home screen.

7.6.1 Welding Parameters

Parameter	Value	Description
Current	2A - 230A	Sets the maximum current level while welding.
Thickness	1.0mm - 12mm	Sets the workpiece thickness.
Pulse	Off / On	Alternates the welding current between a high and low value to aid in heat control and improve weld quality.
Trigger	2T / 4T / HCT / SPOT	Switch between torch trigger modes: Trigger Mode 2T Initiates welding when the torch trigger is pressed and stops when released. Trigger Mode 4T Press the torch trigger once to start welding and release it. Press again to stop the weld. This mode is useful for longer welds and reducing hand fatigue. Trigger Mode HCT Heat Control Trigger (HCT) lets you set a base current which you can switch to at any time during a weld by pressing the trigger button. HCT is great for manual heat input control as you go. Spot Mode Spot mode provides precision in creating timed weld spots with controlled intervals and counts. It's ideal for consistent tacking or producing uniform joints across materials.

Parameter	Value	Description
Wave	<ul style="list-style-type: none"> • DC • DC Square • DC Sine • DC Triangle • AC Square • AC Sine • AC Triangle • AC Square Sine • AC Square Triangle • AC Sine Square • AC Sine Triangle • AC Triangle Square • AC Triangle Sine 	The waveform determines whether you're welding in DC mode or AC mode. Select your desired AC waveform.

7.6.2 Advanced Welding Parameters

Parameter	Value	Description
Pre-Gas	0s - 20s	Sets the duration of shielding gas released before the arc ignites.
Start Amp	2A - 230A	Sets the amperage at the beginning of the welding process.
Up Slope	0s - 20s	Sets the time the welding current takes to rise from the Start Amp to the main welding current.
Peak Amp	2A - 230A	The maximum current level during the weld. This also sets the peak in the pulse cycle.
Base Amp	2A - 230A	Sets the lower current level in the pulse cycle.
Pulse Width	5% - 95%	Sets the time the arc stays at its peak amperage during the pulse cycle.
Frequency	0.5PPS - 999PPS	Sets the number of pulse cycles every second.
Down Slope	0s - 20s	Sets the time the welding current takes to decrease from the main welding current to the End Amp.
End Amp	2A - 230A	Sets the final welding current value before the arc stops.
Post-Gas	0s - 20s	Sets the duration of shielding gas released after the welding arc stops.
Diameter	1.6mm - 3.2mm	Sets the tungsten electrode diameter.
Balance	15% - 50%	Sets the ratio of positive to negative current in the AC cycle.
AC Frequency	50Hz - 250Hz	Sets the number of AC cycles in one second.
Cap Shaping	Off / On	Automatically balls the tungsten end, eliminating manual preparation for enhanced efficiency.
Mixed AC/DC	0% - 80%	Sets the percentage of AC in the mixed TIG cycle.
Amplitude Control	-70% - 70%	Sets the percentage of the AC waveform that is on the negative side for a more penetrative weld.
Speed Start	0s - 60s	Speeds up the formation of the weld puddle by applying a synergic pulse program to the beginning of the weld. Sets how long this initial program runs. TackPlus is unavailable while a Speed Start value is set.
Steady Arc	0A - 50A	Sets the amount of adjustment on the welding current based on the arc voltage. When the voltage goes down, the amperage will go up, and vice versa, to give a consistent weld puddle, a sharper arc and a constant heat input. TackPlus is unavailable while a Steady Arc value is set.
TackPlus	0Hz - 6Hz	Create evenly spaced and sized fusion tack welds along a joint with minimal heat input. Sets the frequency of the tack welds. Speed Start and Steady Arc are unavailable while a TackPlus value is set.
Spot Time	0.1s - 10s	Sets the duration for each spot weld.
Min Amp	2A - 230A	Sets the minimum amperage of the machine. Only available when in Remote Mode.
Purge	N/A	Purge your gas lines by pressing and holding/clicking on and off.

 **The settings available in the advanced welding parameters screen will depend on the standard welding parameters selected.**

7.7 Job Menu



1. **Press** the Job button to open the Job Menu screen.
2. **Turn** the left or right control knob to choose an option. **Press** to select it.

7.7.1 Saving a Job

1. On the weld screen and parameters you want to save, press the Job button. **Press** either control knob to select Save.
2. **Press** either control knob to select New Job.
3. Choose a name for the job. **Turn** the right control knob to navigate the keyboard and **press** it to select each letter. **Press** Enter to save.

7.7.2 Overwriting a Job

1. In the Save Job screen, **Turn** either control knob to hover over and **press** to select the job you want to overwrite.
2. **Turn** the right control knob and **press** to select Overwrite. This will erase the previous job stored under that name.

7.7.3 Importing a Job

Info If you don't have a USB plugged into the machine, you will get a warning message in the top left corner 'No USB storage device detected, please connect the USB storage device and try again'.

1. **Press** either control knob to select Import to bring up the USB files.
2. **Press** and **turn** either control knob to select the job(s) you want to import.

7.7.4 Exporting a Job





Info If you don't have a USB plugged into the machine, you will get a warning message in the top left corner 'No USB storage device detected, please connect the USB storage device and try again'.

1. **Press** either control knob to select Export.
2. A popup 'Export complete' will appear if the export was successful.







7.7.5 Deleting a Job

There are two options to delete a job: Delete All or Delete.

To delete every saved job on the machine:

1.  **Turn** and  **press** either control knob to select Delete All. A confirmation message will appear.
2.  **Turn** and  **press** the right control knob to select Delete to confirm.

To delete a single job on the machine:

1.  **Turn** and  **press** either control knob to select Delete.
2. In the Delete Job menu,  **turn** and  **press** either control knob to select the job you want to delete. A confirmation message will appear.
3.  **Turn** and  **press** the right control knob to select Delete to confirm.

7.8 Settings Menu

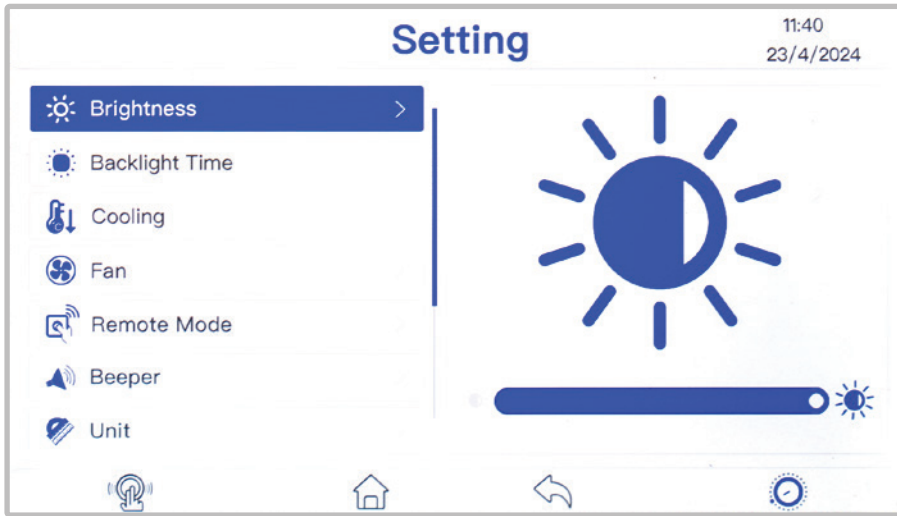

1. **Press** the Settings button to open the Settings Menu screen.
2. **Turn** the left control knob to select the setting.
3. **Turn** and/or **press** the right control knob to adjust the selected setting.

7.8.1 Welding Parameters

Setting	Value	Description
Brightness	1-18	Sets the brightness level of the screen.
Backlight Time	15min / 30min / 1h / Never	Sets the amount of time before standby mode activates.
Cooling	Air / Water	Sets the type of cooling.
Fan	Normal / Smart	Sets the type of fan operation.
Remote Mode	Remote OFF / Remote Torch / Remote Pedal / Bluetooth Connection	Sets the remote mode of the machine. Press the right control knob to scroll through the remote settings. Selecting Bluetooth Connection with a wireless foot pedal connected will open its own right side menu.
Bluetooth Connection		This menu can only be entered with a wireless foot pedal connected. <ul style="list-style-type: none"> • Disconnect: Disconnect the foot pedal from the machine. • Rename: Rename the device that's connected. • Auto Connect (OFF/ON): Set whether the foot pedal automatically connects to the machine. • Sleep time: Set the length of time before the pedal enters sleep mode. • Shutdown time: Set the length of time before the pedal shuts off.
Beeper	1-20	Sets the volume level of the beeper during machine operation.
Unit	Metric / Inch	Sets the unit of measurement.
Clock	Year / Month / Day / Hour / Minute	Sets the date and time displayed on the machine.
Information		Machine information, working time and up time.
Factory Reset	No / Yes	Factory reset the machine. Press the right control knob to enter the menu choice beyond the warning.
Program Update	Yes / No	Update the software version of the machine. Press the right control knob to enter the menu choice beyond the warning.

7.9 Operating the Water Cooler

1. Ensure there is coolant in the tank and that the welding torch is connected.
2. Switch the ENVY TIG 230 AC/DC to 'Water' under Cooling in the **Settings Menu**.

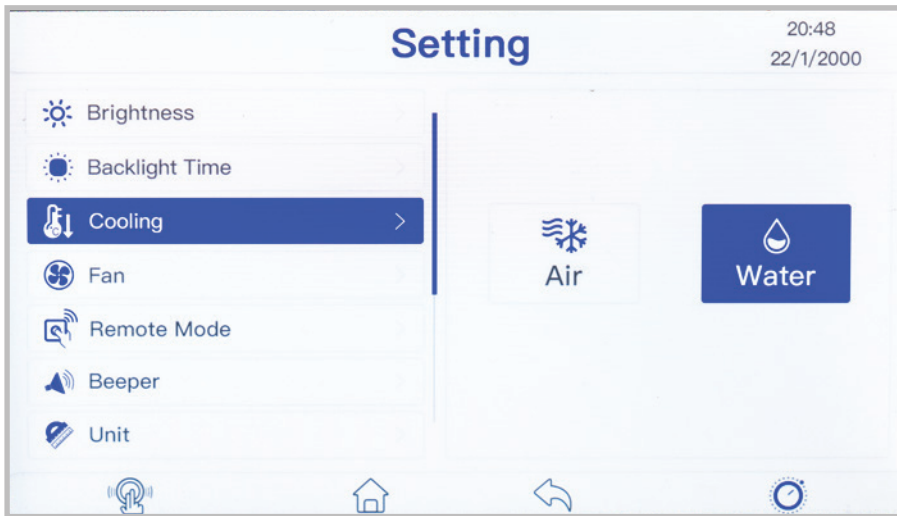

3. Press the coolant circulation button on the back of the water cooler. This activates a pump motor which pumps the coolant into the hoses and to the welding torch. It will highlight blue when running.

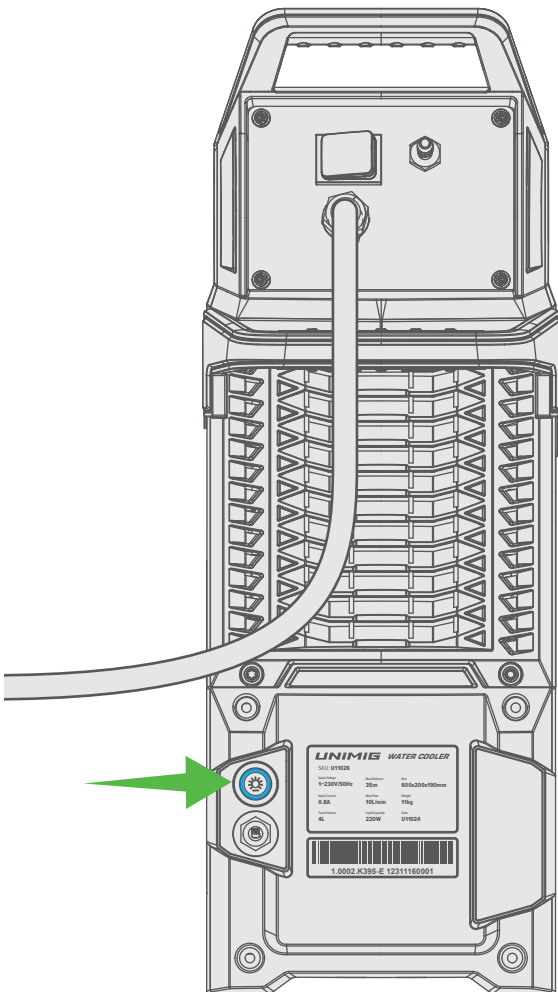

i If the system detects that there isn't enough coolant in the unit, it will display error code E11, and the machine will need to be restarted to remove this error.

8. Maintenance

How often the machine is used and the working environment it is in should both be considered when planning the frequency of maintenance. In severe conditions, maintenance should occur more frequently.

Proper operation of the machine and regular preventive maintenance will help avoid equipment failure, increase the life-span of the machine and ensure problem-free welding.

⚠ Turn the machine off and unplug it from the mains before beginning any maintenance.

Before each use, check your gas hose, earth clamp and cable, and power cable are in good condition. Check that all connections are properly fastened. Any loose connections can inhibit welding performance and cause damage.

- Check that all covers and components are intact.
- Check all electrical cables and connections every 6 months.
- Clean any oxidised connections and tighten them.
- Clean dirt and dust from the outside and inside of the unit with a vacuum cleaner and soft brush.

ⓘ Do not use any pressure-washing devices. Do not use compressed air, the pressure may pack the dirt even more tightly into components.

⚠ Only authorised electricians or service repair agents should carry out repairs and internal servicing.

For repairs, contact UNIMIG at unimig.com.au or contact your local dealer.

9. Troubleshooting

i The issues and potential reasons outlined are not exhaustive but indicate common scenarios that might arise with regular use of the machine.

9.1 Machine Troubleshooting

Problem	Recommended Actions
The machine does not power up	<ul style="list-style-type: none"> • Check that the power cable is plugged in properly. • Check that the mains switch of the power source is at the ON position. • Check that the mains power distribution is on. • Check the mains fuse and/or the circuit breaker.
The machine stops working	<ul style="list-style-type: none"> • The torch may have overheated. Wait for it to cool down. • Check that none of the cables are loose. • The power source may have overheated. Wait for it to cool down and see that the cooling fans work properly and the air flow is unobstructed.

9.2 TIG Troubleshooting

Problem	Recommended Actions
Tungsten burning away quickly	<ul style="list-style-type: none"> • Check that the correct gas is being used. • Check the gas is connected, check hoses, gas valve and torch are not restricted or leaking. Set the gas flow to the recommended flow rate. • Check the back cap is fitted correctly and that the O-ring is inside the torch body. • The polarity may be wrong, check the polarity (See "6.4 Connecting the TIG Torch" on page 25). • Check the right tungsten is being used and change the tungsten type if necessary. • Keep the shielding gas flowing 10-15 seconds after arc stoppage to prevent tungsten oxidation.
Contaminated tungsten	<ul style="list-style-type: none"> • Don't let the tungsten touch the weld pool. Raise the torch so that the tungsten is off the workpiece 2-5mm. • Don't let filler rod touch the tungsten during welding. Feed the filler rod into the leading edge of the weld pool in front of the tungsten.
Porosity	<ul style="list-style-type: none"> • Check that the correct gas is being used. • Check the gas is connected, check hoses, gas valve and torch are not restricted or leaking. Set the gas flow to the recommended flow rate. • Remove materials like paint, grease, oil, and dirt, including mill scale, from the base metal & filler rod. • Check the filler rod is correct and change if necessary.
Yellowish residue/smoke on the ceramic cup & discoloured tungsten	<ul style="list-style-type: none"> • Check that the correct gas is being used. • Check the gas is connected, check hoses, gas valve and torch are not restricted or leaking. Set the gas flow to the recommended flow rate. • The cup size may be too small, use a bigger cup size.
Unstable arc while welding	<ul style="list-style-type: none"> • The polarity may be wrong, check the polarity (See "6.4 Connecting the TIG Torch" on page 25). • Remove materials like paint, grease, oil, and dirt, including mill scale, from the base metal. • The tungsten may be contaminated, remove 10mm of the contaminated tungsten and re-grind the tungsten. • The arc length may be too long, lower the torch so that the tungsten is off the workpiece 2-5mm.

Problem	Recommended Actions
Arc wandering while welding	<ul style="list-style-type: none"> • Check the gas is connected, check hoses, gas valve and torch are not restricted or leaking. Set the gas flow to the recommended flow rate. • The amperage may be too low, increase the amperage. • The arc length may be too long, lower the torch so that the tungsten is off the workpiece 2-5mm. • Check that correct type of tungsten is being used and it's not contaminated. Remove 10mm of the contaminated tungsten and re-grind the tungsten. • The tungsten may be poorly prepared. Grind marks should run lengthwise with tungsten, not circular. • Remove materials like paint, grease, oil, and dirt, including mill scale, from the base metal & filler rod.
Arc difficult to start or won't start	<ul style="list-style-type: none"> • Check the machine set up is correct. • Check that the correct gas is being used. • Check the gas is connected, check hoses, gas valve and torch are not restricted or leaking. • Check the right type & size tungsten is being used and change the tungsten type if necessary. • Check all the connections are tight. • Connect the earth clamp directly to the workpiece.

9.3 MMA Troubleshooting

Problem	Recommended Actions
No arc	<ul style="list-style-type: none"> • Check the earth lead and all connections are tight. • Check that the machine is switched on and has a power supply. • Check that the weld mode is set to the MMA position.
Porosity	<ul style="list-style-type: none"> • The arc length may be too long, move the electrode closer to the workpiece. • Remove materials like paint, grease, oil, and dirt, including mill scale, from the base metal. • Only use dry electrodes.
Excessive spatter	<ul style="list-style-type: none"> • The amperage may be too high, reduce the amperage. • The arc length may be too long, move the electrode closer to the workpiece.
Lack of fusion	<ul style="list-style-type: none"> • The amperage may be too low, increase the amperage. • Remove materials like paint, grease, oil, and dirt, including mill scale, from the base metal. • Use the correct welding technique (See "12. MMA Welding Guide" on page 65).
Lack of penetration	<ul style="list-style-type: none"> • The amperage may be too low, increase the amperage. • Use the correct welding technique (See "12. MMA Welding Guide" on page 65). • Check the joint design and fit up is correct and the material isn't too thick.
Excessive penetration/Burnthrough	<ul style="list-style-type: none"> • The amperage may be too high, reduce the amperage. • Increase the travel speed.
Uneven weld appearance	<ul style="list-style-type: none"> • Use two hands where possible to hold the electrode steady. • Use the correct welding technique (See "12. MMA Welding Guide" on page 65).
Distortion	<ul style="list-style-type: none"> • The amperage may be too high, reduce the amperage. • Use the correct welding technique - (See "12. MMA Welding Guide" on page 65). • Check the joint design and fit up is correct and the material isn't too thick.
Unusual or poor arc characteristics	<ul style="list-style-type: none"> • The polarity may be wrong, check the polarity (See "6.5 Connecting the MMA Electrode Holder" on page 27).

9.4 Error Codes

Error Code	Name	Description	Potential Action
E01	Hot Protect	The welder is overheating.	Check the fan is operating, wait for the welder to cool down. If the problem persists, contact UNIMIG customer service.
E02	Hot Protect	The welder is overheating.	Check the fan is operating, wait for the welder to cool down. If the problem persists, contact UNIMIG customer service.
E09	Program Protect	The welder has reached its duty cycle.	Wait for the welder to cool down.
E11	No Water	The water cooler unit does not have enough coolant.	Add more coolant. If there is coolant in the unit, check the water cooler wiring and the motor is running. If the problem persists, contact UNIMIG customer service.
E13	Under Voltage	The machine isn't getting enough voltage to operate.	Remove extension leads or try a different outlet. If the problem persists, contact UNIMIG customer service.
E15	Over Current	The machine output is exceeding its limit.	If the problem occurs, contact UNIMIG customer service.
E18	PFC Error	The PFC board in the machine isn't working.	This error displays on shutdown, this is normal and not a hardware failure. If the problem occurs not on shutdown, or persists, contact UNIMIG customer service.
E19	Second Inverter Under Voltage	The secondary inverter board is not getting enough voltage.	If the problem occurs, contact UNIMIG customer service.
E25	Primary Inverter Over Current	The output current of the main PCB is exceeding its limit.	Generally caused by a hardware failure, contact UNIMIG customer service.
E31	Water Cooler Disconnected	The water cooler is not connected.	Check the water cooler wiring. If the problem persists, contact UNIMIG customer service.
E32	Coolant Over Temperature	The temperature of the coolant exceeds 70°C.	Wait for the coolant temperature to fall below 65°C.
E41	Communication Error	Communication error between the control board and the display board.	Check the wire between the control board and the display board. If the problem persists, contact UNIMIG customer service.
E42	Password Error	Main board password is wrong.	The screen calibration may have failed, try again. If the problem persists, contact UNIMIG customer service.
E60	Thermal Sensor Error	The thermal sensor has not be installed correctly.	Check the thermal sensor wiring. If the problem persists, contact UNIMIG customer service.

10. General Welding Information

10.1 Metal Preparation

Proper preparation of the metal surface is crucial for achieving a good quality weld and cannot be overstated. Each type of metal may require slightly different approaches, especially in terms of cleaning and edge preparation, to adapt to its specific properties and behavior during welding.

Mild Steel

- **Cleaning:** Start by removing any rust, paint, oil, or grease from the surface. Use a wire brush or grinder to clean the metal. It's essential to start with a clean surface to avoid contamination of the weld pool.
- **Degreasing:** Wipe down the surface with a solvent such as acetone or a commercial degreaser to remove any residual oils or contaminants that might interfere with the welding process.
- **Edge Preparation:** If welding thicker pieces, bevel the edges to allow the weld to fully penetrate the joint. The angle and depth of the bevel depend on the thickness of the metal.
- **Fit up:** Ensure that the pieces to be welded fit together well without large gaps. A good fitup helps achieve a strong and uniform weld.

Stainless Steel

- **Cleaning:** Similar to mild steel, all surfaces must be cleaned of any contaminants. Use a stainless steel wire brush (one dedicated to stainless steel to avoid cross-contamination with other metals) to remove any surface debris.
- **Degreasing:** Clean the surface with a high-purity solvent like acetone to remove any oils or residues. This step is crucial for stainless steel to prevent any interference with the weld quality.
- **Edge Preparation:** Bevel the edges if necessary, especially for thicker pieces. Stainless steel requires precise edge alignment to ensure a quality weld, so take extra care during this step.
- **Avoiding Contamination:** Use dedicated tools for stainless steel to avoid iron contamination from regular steel tools. This can lead to rust and corrosion.

Aluminium

- **Cleaning:** Aluminium oxidises very quickly when exposed to air. Use a stainless steel wire brush to remove the oxide layer just before welding, as this layer can contaminate the weld pool if not removed.
- **Degreasing:** Clean the metal with a solvent like acetone immediately after brushing to ensure that no oils or moisture are present, which can cause porosity in the welds.
- **Edge Preparation:** Beveling may be necessary depending on the thickness of the metal. Aluminium requires careful preparation as it is more sensitive to heat and can warp easily.
- **Drying:** Aluminium has a high affinity for moisture, so ensure that the metal is completely dry before welding. Moisture can lead to hydrogen porosity in the weld.

10.2 Beveling

The standard bevel for pipe and plate in welding is primarily determined by the thickness of the materials and the type of weld joint being prepared. Beveling is done to ensure that the weld can fully penetrate the joint, which is crucial for the structural integrity of the weld. It is primarily used to prepare butt joints for welding.

Here's a general breakdown of typical bevels used for both pipes and plates:

Thickness below 3mm: Typically, no beveling is required for material thinner than 3mm. A square butt joint is usually sufficient as the weld can penetrate through the entire thickness.

Thickness 3mm to 12mm: A single-V bevel is often used. The angle might start from about 30° for thinner sections up to about 37.5° for closer to 12mm thick material.

Thickness above 12mm: Double-V bevels become more common as the thickness increases, reducing the amount of filler material needed and ensuring better weld penetration.

The specific bevel angle and type also depend on the welding standards being followed (such as AWS, ASME, etc.), the welding process used, and the requirements of the specific project or industry. For precise applications, always refer to the welding specification or consult a welding engineer to determine the most appropriate bevel for a given situation.

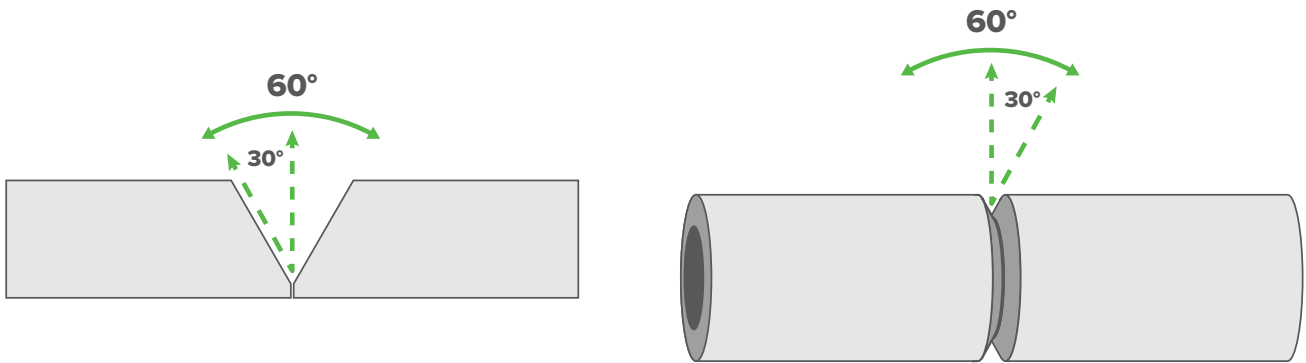

11. TIG Welding Guide

What is TIG Welding?

Tungsten Inert Gas (TIG) welding is an arc welding process in which an arc is formed between a non-consumable tungsten electrode and the workpiece to create the weld.

Filler metal is added manually, though it isn't always necessary.

An inert shielding gas is fed through the TIG torch to protect the weld from outside contaminants.

TIG welding is also known as Gas Tungsten Arc Welding (GTAW).

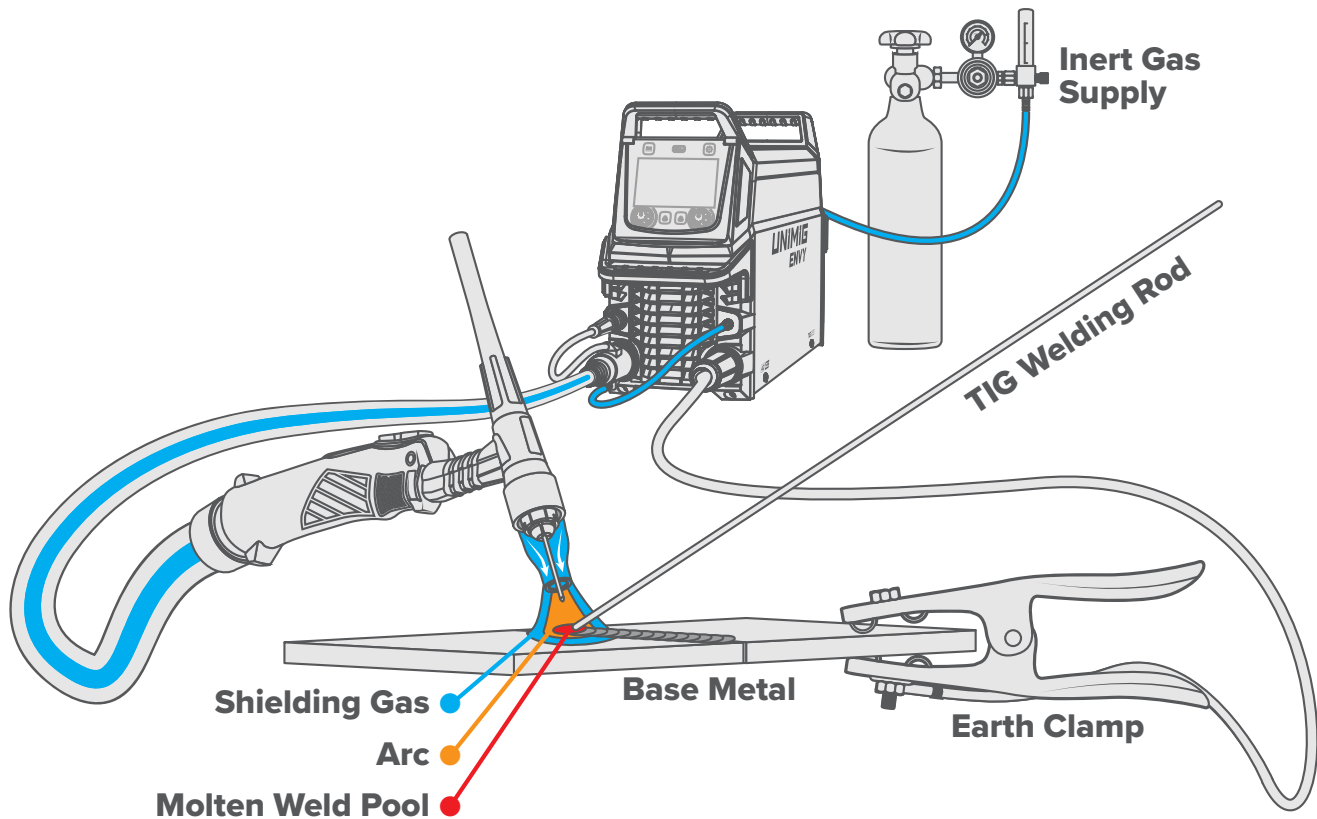

How TIG Welding Works

You can TIG weld two different ways: with alternating current (AC) or direct current (DC). Both need to be run on a constant-current power source to work. Both AC and DC TIG welding are done in negative polarity or Direct Current Electrode Negative (DCEN).

The current is negatively charged and runs from the positive to the negative. This means that 70% of the heat of the arc is concentrated in the workpiece.

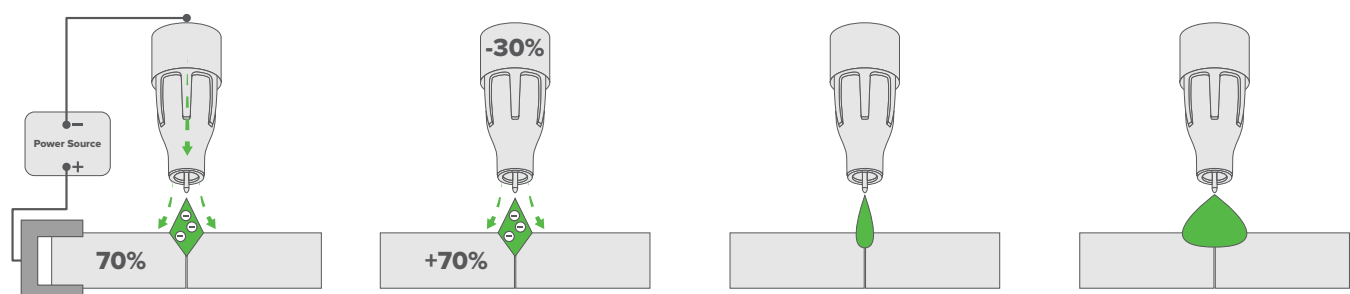

An arc is formed between the tungsten electrode and the workpiece. Tungsten has a melting point of 3,422°C, so it can withstand the heat of a welding arc. That's why it is a 'non-consumable' electrode. It doesn't melt and enter the weld pool. To add metal, an additional filler rod can be fed into the weld puddle by hand to form a proper weld.

TIG welding is the only welding process that requires the use of both hands to create the weld, so it is a completely manual process that has a steeper learning curve than MIG or MMA.

Lift Arc TIG Welding

Lift arc is a form of arc ignition which is done by touching the tungsten electrode to the workpiece and lifting it up to start the arc. When the machine detects that the tungsten has left the surface and a spark is present, it immediately (within microseconds) increases power, converting the spark to a full arc.

Lift arc ignition stops the tungsten tip from sticking to the workpiece and breaking the tungsten electrode, and is a superior option to scratch start.

There is a particular technique called "rocking the cup" used which is the easiest way to start an arc with lift arc.

Hold your torch at a 45° angle, with the gas shroud resting on the workpiece, without touching your tungsten to the metal. Then, in one motion, move the torch up to a 90° angle as the tungsten electrode touches the metal, and then lift it off the workpiece roughly 3mm to initiate the arc.

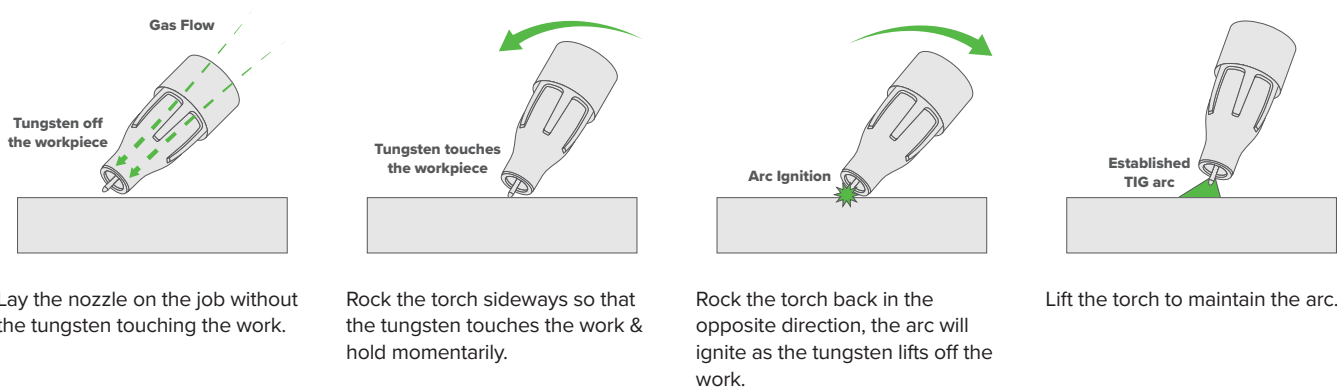

High-Frequency TIG Welding

High-frequency ignition allows the arc to be started without touching the tungsten to the workpiece. By pressing the torch trigger the machine will activate the gas flow and the high-frequency spark. The spark 'ionises' the air gap, making it conductive, and allowing an arc to be created without touching the tungsten to the workpiece.

High-frequency arc starts remove any chance of tungsten contamination and are the easiest way to start an arc. A high-frequency machine also allows the addition of a foot pedal and other remotes.

AC Frequency

An alternating current (AC) flows between the negative polarity (-) and positive polarity (+) in a 'cycle'. The AC frequency determines how many cycles are completed per second. This is usually indicated as Hertz (Hz), with the standard base frequency being around 100-120Hz.

Turning your frequency up and down will change your weld profile. The higher the frequency, the more cycles per second, which creates a thinner, more prominent weld appearance as the arc becomes smaller and more focused. The lower your frequency, the flatter your weld will be, widening the weld bead.

A higher frequency is usually recommended for thinner metals, as the arc is tighter, so you can be more accurate in thin joints (like outside corners).

Slower AC Square Wave Hz

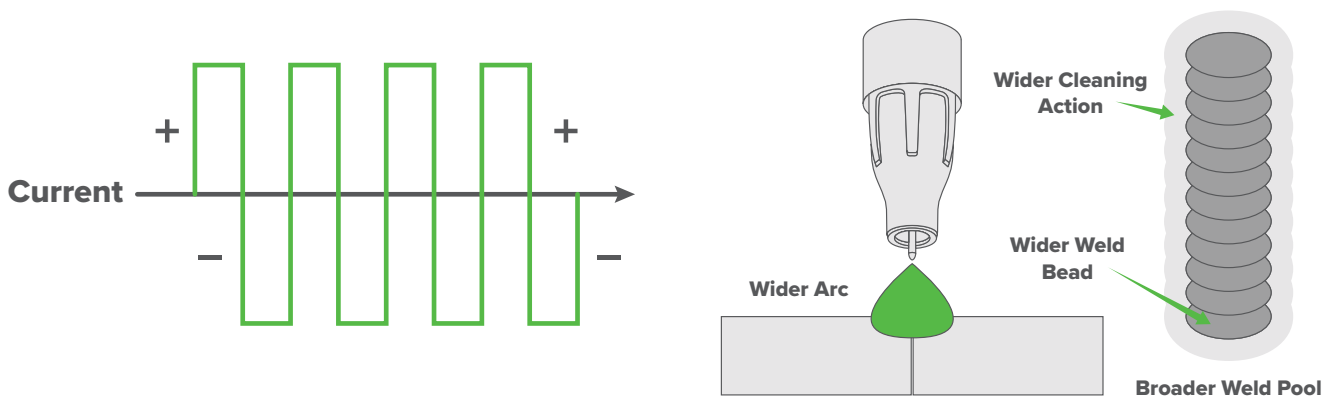

Faster AC Square Wave Hz

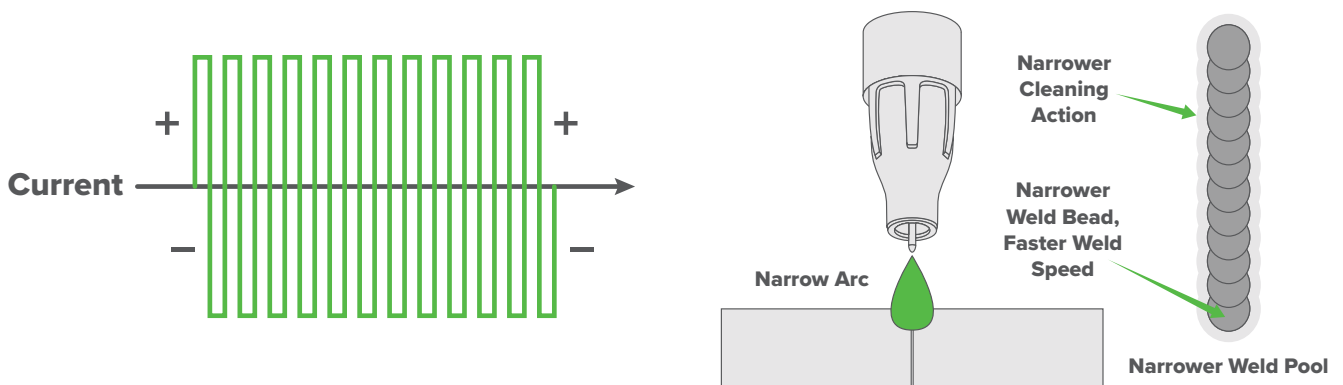

AC Balance

AC (alternating current) enables us to TIG weld non ferrous alloys like aluminium, magnesium and aluminium alloys. These materials have an insulating surface oxide layer that melts at a higher temperature than the base metal. For example, aluminium melts at around 660°C, but the oxide layer on top melts at about 2000°C.

Because it flows from positive polarity (+) to negative polarity (-), it's ideal because the AC waveform assists in breaking the surface oxide layer. The positive part of an AC cycle works to break down the oxide layer (cleaning), and the negative part is what provides the heat and penetration for the weld.

Increasing your positive percentage will increase the cleaning on your workpiece. However, the more your cleaning is increased, the less penetration you're going to have. Though it sounds balanced, a 50/50 balance won't have enough heat to form a weld pool.

Besides your lack of penetration, upping the cleaning means spending longer in the positive part of your AC cycle. The longer you spend in the positive, the hotter your tungsten gets. This heat, however, does not get transferred into the metal. Instead, it sits inside the tungsten, which will result in your tungsten balling and melting off.

A 30% positive/70% negative AC balance ratio is a generally optimal balance for most aluminium welding.

Balance adjusted for more penetration - Cooler tungsten

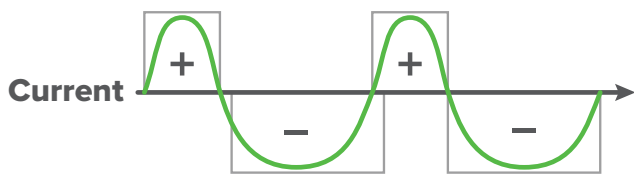

Less Positive Balance

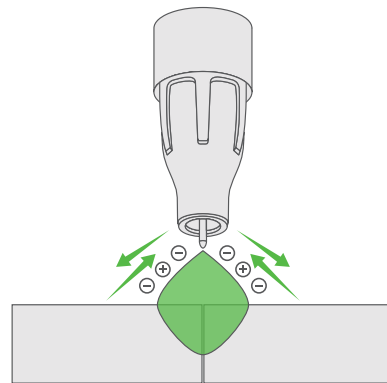

Balance adjusted for more oxide cleansing action - Hotter tungsten

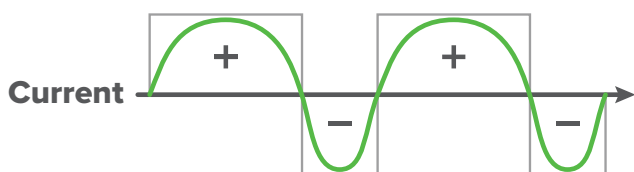

More Positive Balance

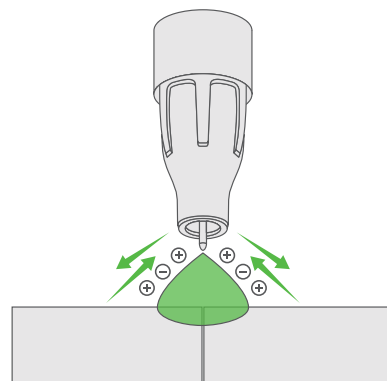

Pulse TIG

Pulse welding is a form of welding in which the amperage alternates between a high point and a low point. The high point is referred to as the peak amperage, and the low point is referred to as the base amperage. Pulse welding keeps the overall heat input of a weld low while still maintaining proper penetration.

There are four main variables when it comes to pulse welding: what the peak amperage is, what the base amperage is, how often it pulses, and how long it spends in either amperage setting.

Peak Amperage

The peak amperage is the main welding current set to melt the material being welded and works much the same as setting the maximum amperage values for regular TIG.

Base Amperage

The base amperage is the set level of background current which cools the weld puddle and effects the overall heat input. As a rule, you want enough background current to reduce the weld pool to about half its normal size while still keeping the weld pool fluid, or around 20%-30% of the peak amperage.

Pulse Frequency

The pulse frequency is the number of pulses per second. 1PPS equals one pulse per second, and 50PPS is 50 pulses per second.

If you're welding thin material, then a fast pulse is better, and it will produce a high profile bead. If you're welding thick material, then a slow pulse is better, and it will produce a low profile bead.

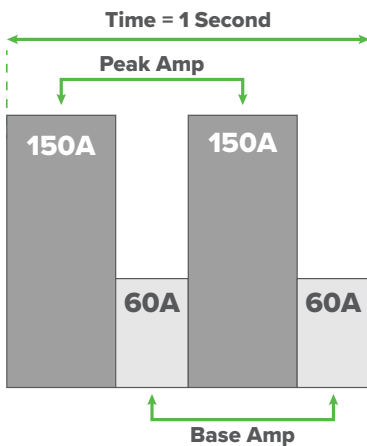

Pulse Width

The pulse percentage is the amount of time spent in the peak and base amperage for each pulse. If you set the percentage to 50%, that means 50% of the pulse cycle will be the peak amperage, and 50% of the pulse will be the base amperage.

You can adjust this either way, where 90% is almost entirely peak amperage and 20% is almost no peak amperage. The more time spent on the peak amperage part of the pulse, the more penetration you're going to get and vice versa.

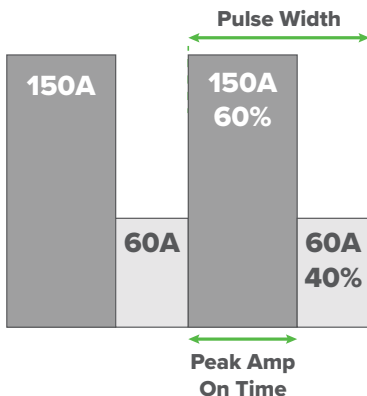

Filler Technique

When TIG welding, you'll almost always need to add filler for good reinforcement and a strong weld. Start the arc and hold the torch in place until a weld pool of the desired size has formed. Once the weld pool is established, tilt the torch at about a 75° angle and move along the joint.

The filler rod is usually held at about a 15° angle and fed into the leading edge of the molten pool. The arc will melt the filler rod into the weld pool as the torch is moved forward. A dabbing technique can be used to control the amount of filler rod that's added. A good rule of thumb is to add the same amount on each dab as the rod's width.

The rod is fed into the molten pool and retracted in a repeating sequence as the torch is moved slowly and evenly forward. It is essential during the welding to keep the molten end of the filler wire inside the gas shield as this protects the end of the wire from being oxidised and contaminating the weld pool.

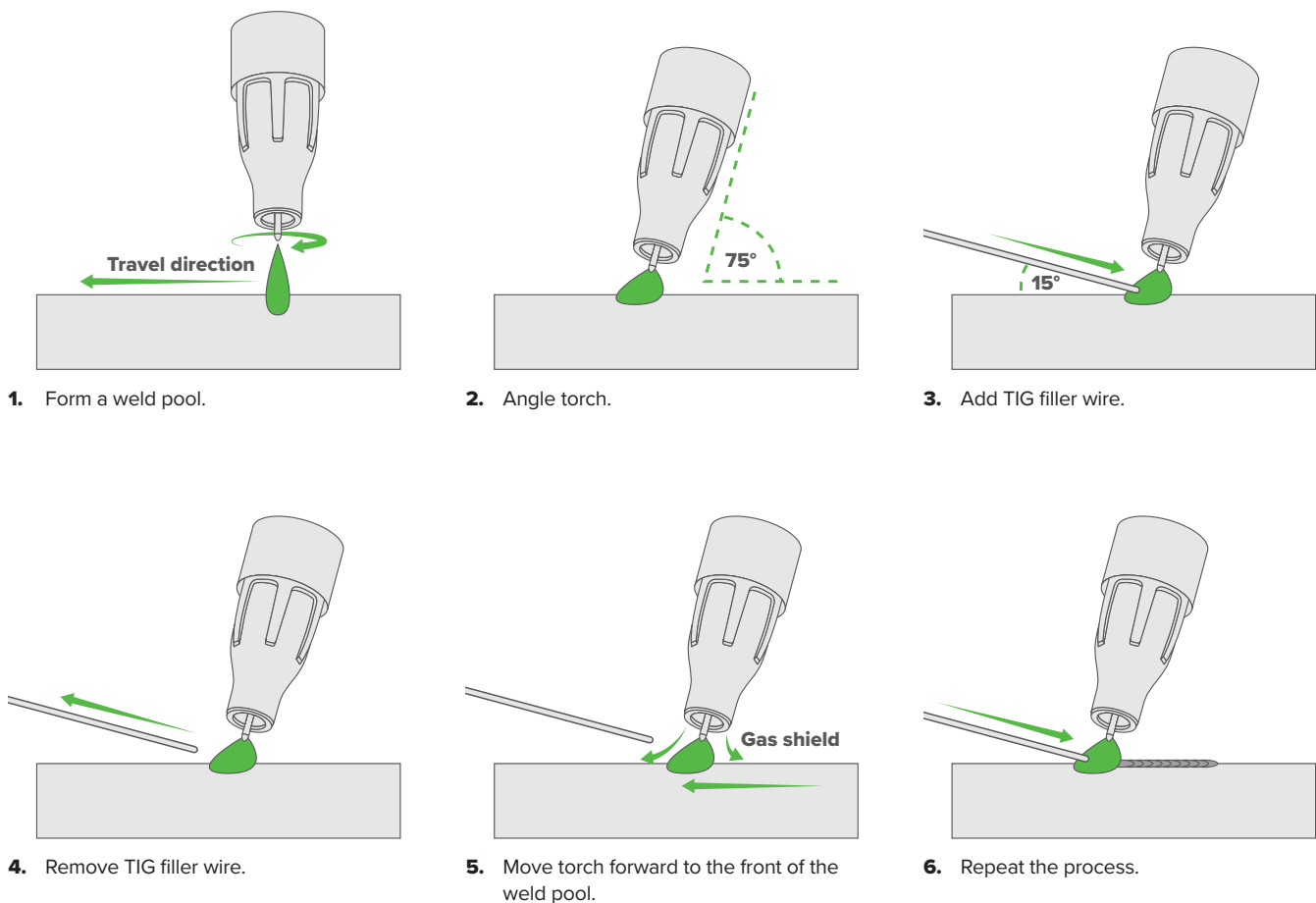

Fusion Technique

While filler material is required a majority of the time, there are some instances when TIG welding where it isn't needed. This is known as fusion, or autogenous, welding. The edges of the metal pieces are melted together using only the heat and arc force generated by the TIG arc.

Fusion welding is done the exact same way as TIG welding with filler, minus the filler rod. Start the arc and hold the torch in place until a weld pool of the desired size has formed. Once the weld pool is established, tilt the torch at about a 75° angle and move slowly and evenly along the joint, fusing the materials together.

Fusion welding is primarily used when combining thin materials on edge, corner, and butt joints.

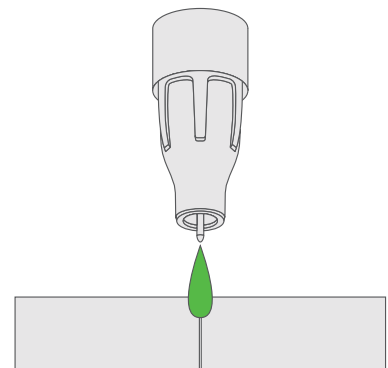

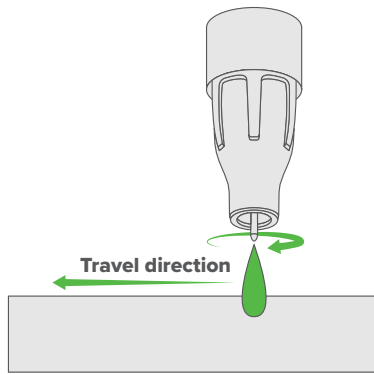

1. Form a weld pool.

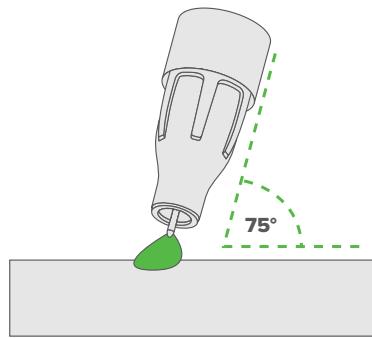

2. Angle torch.

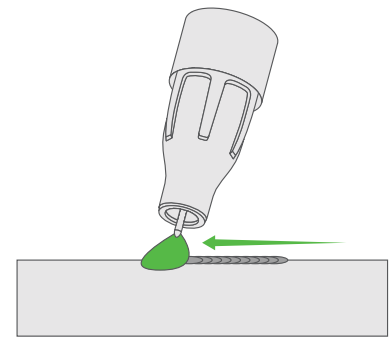

3. Move the torch slowly and evenly forward.

Tungsten Selection

	 LANTHANATED (GOLD)	 ZIRCONIATED (WHITE)	 THORIATED (RED)	 RARE EARTH (PURPLE)	 CERATED (GREY)
AC CURRENT	✓	✓		✓	✓
DC CURRENT	✓		✓	✓	✓
ALUMINIUM	✓	✓		✓	✓
MILD STEEL	✓		✓	✓	✓
STAINLESS STEEL	✓		✓	✓	✓
TITANIUM / COPPER ALLOYS	✓		✓	✓	✓
ARC IGNITION	●●●●●	●●●●●	●●●●●	●●●●●	●●●●●
TUNGSTEN LIFE	●●●●●	●●●●●	●●●●●	●●●●●	●●●●●
ARC STABILITY	●●●●●	●●●●●	●●●●●	●●●●●	●●●●●
RESISTANCE TO CONTAMINATION	●●●●●	●●●●●	●●●●●	●●●●●	●●●●●
AC PERFORMANCE	●●●●●	●●●●●	N/A	●●●●●	●●●●●

This information is intended to act as a guide only, individual results may vary depending on technique, skill and material.

Tungsten Preparation

There are a few different ways to prepare your tungsten, and different shapes will give different results on different applications.



The most common tungsten shape to weld stainless and mild steel with is pointed, which produces a focused and stable arc, and works for all DC applications. To get this pointed shape, you'll need a tungsten grinder or a bench grinder (a diamond wheel is best).

If you use a bench grinder, it needs to be dedicated to tungsten preparation, as you can contaminate your tungsten with anything that's leftover on the grinder.

Press your tungsten vertically to the grinder at a 30° angle and rotate at a consistent pace until a point has formed. It's essential to grind with the tungsten's grain (lengthwise) and not against it (horizontal on the grinder) for a few reasons.

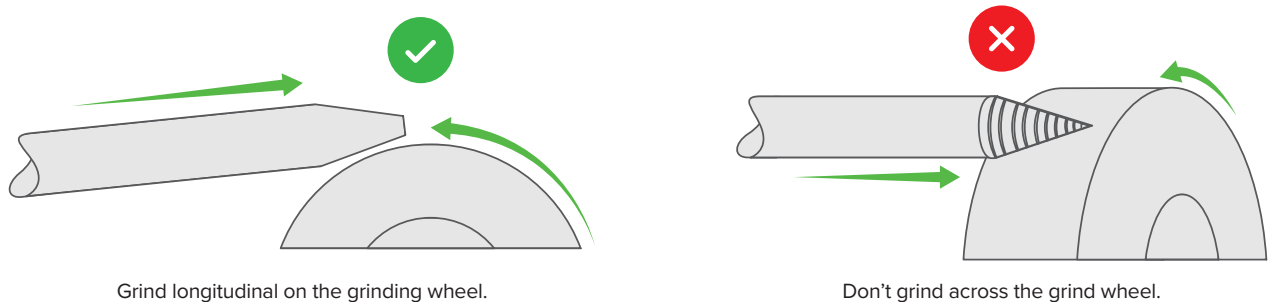

The main reason is that it lowers the number of ridges in the tip of the tungsten. More ridges mean that the arc has more surface to cover, increasing your chances of it wandering or the tip melting off and falling into your weld pool. Your tungsten will also stay sharper for longer if you follow the grain, so you won't need to re-grind it as often.

A truncated/flat tip follows the same preparation as a pointed tip but with the added step of grinding the end, so you get a flat top. This shape works well for both AC and DC applications.

AC Tungsten Preparation

A balled tip is usually recommended if you're welding aluminium.

1. First, prep your tungsten in the same way as you would a pointed tungsten, with a roughly 30° angle on the tungsten ending in a pointed tip.
2. Turn on the 'Cap Shaping' setting on your machine found in the advanced parameters  menu in HF TIG or Smart TIG, press the torch trigger, and the tungsten will automatically form a small ball on the tip.

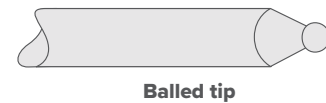
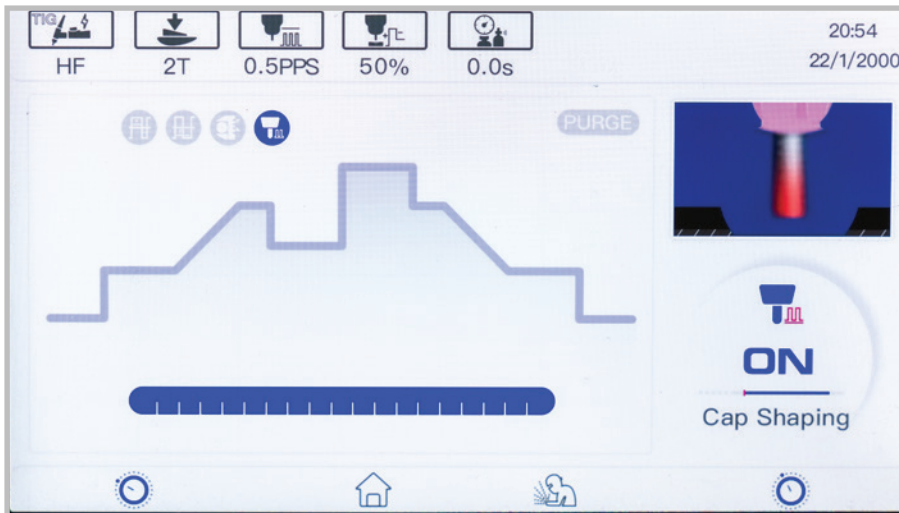

The other option is to set your machine to DC electrode positive (DCEP), hold the torch 90° on a piece of copper and start the arc to form a ball. This tungsten preparation method happens after you have set up your gun and machine, though, not before.

Gas Coverage Check

To ensure you have adequate gas coverage, first form a weld pool on a test piece of metal, then release the trigger and allow for 8-10 seconds of post-flow. If the gas coverage is sufficient, the weld pool will appear shiny and clear. Conversely, if the gas coverage is poor, the weld pool will look dark and sooty.

To address gas coverage issues, make sure the post-flow timing is accurate and adjust the flow rate according to the type of gas and the thickness of the material. (See "Recommended Gas Flow Rates" on page 32).

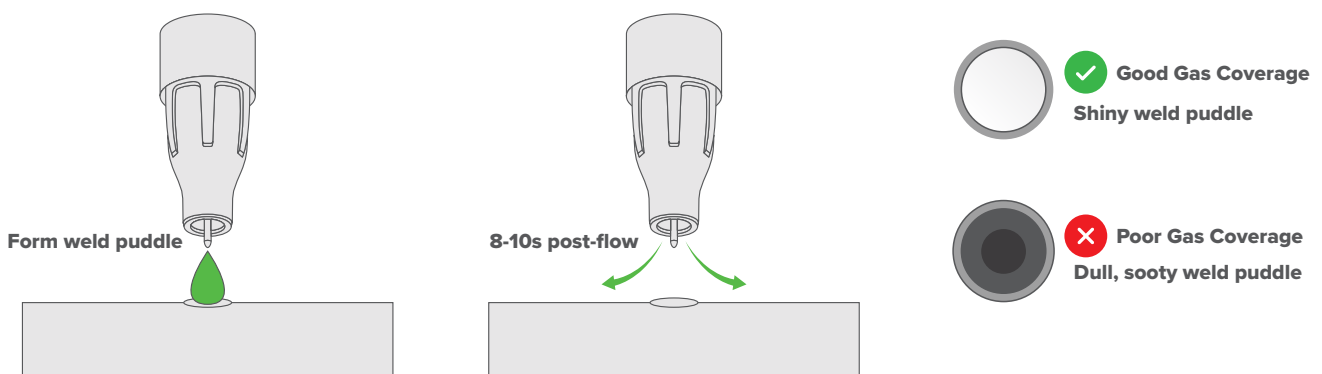

12. MMA Welding Guide

What is MMA Welding?

Manual Metal Arc (MMA) welding is an arc welding process in which an arc is formed between a flux-covered electrode and the base metal. The arc melts the electrode into the workpiece, forming the weld.

MMA is also referred to as Shielded Metal Arc Welding (SMAW), but it's most commonly known as 'stick' welding.

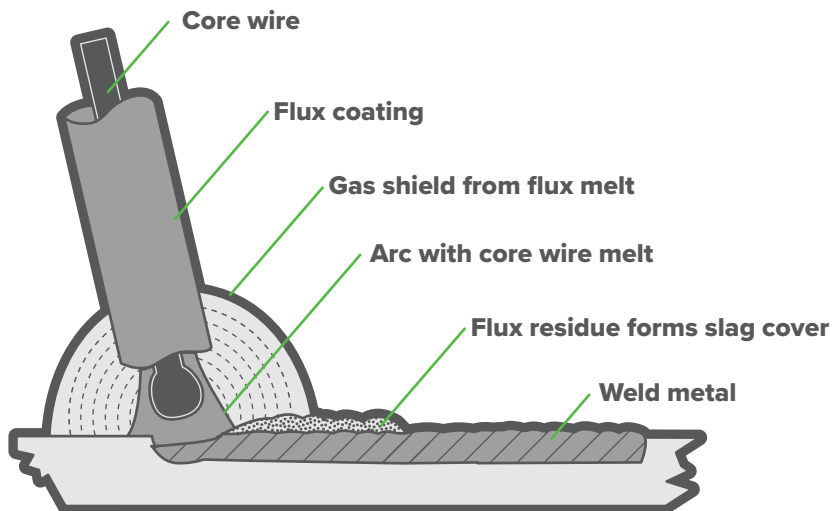

How MMA Welding Works

You can MMA weld two different ways: with alternating current (AC) or direct current (DC). Both need to be run on a constant-current power source to work. The electrode is tapped or struck against the base metal, which ignites the arc between the two. The electrodes used in MMA welding are consumable electrodes, as they melt into the base metal to form the weld.

An external gas isn't needed as the outer flux coating on each electrode works to shield the weld as it melts. The flux coating melts with the metal, releasing gases from within which bubble to the surface.

These internal gases protect the weld from outside contaminants until the puddle begins to cool. The flux coating, once melted, forms a layer of slag over the final weld, which needs to be chipped off to achieve a clean, finished weld.

Electrode Selection

There is a range of different electrodes available for MMA welding. Each is stamped with its own classification code, which details the properties of each electrode. For mild steel electrodes, there is an 'E' followed by a 4-digit code, for example, E6013.



You'll need to select an electrode with a similar composition to the base metal. Generally speaking, the most common electrodes used for mild steel are E6010, E6011, E6013, E7016, E7018 and E7024. Stainless steel electrodes are marked with their metal grade, e.g., 309L.

The size of the electrode generally depends on the thickness of the section being welded, and the thicker the section,

the larger the electrode required. The table gives the maximum size of electrodes that may be used for various thicknesses of section based on using a general-purpose type 6013 electrode.

Average Thickness of Material	Maximum Recommended Electrode Diameter
3-6mm	2.6mm
6-12mm	3.2mm
12-20mm	4.0mm
20mm+	5.0mm

The amperage you'll need is dependent on the electrode size and base metal thickness.

With the amperage set too low, it's difficult to strike and maintain a stable arc. The penetration is reduced and beads with a distinct rounded profile will be deposited. Too high an amperage is accompanied by overheating of the electrode, resulting in undercut, burning through of the base metal and producing excessive spatter.

Electrodes will usually come with a recommended amperage rating. The table shows current ranges generally recommended for a general-purpose type 6013 electrode.

Electrode Size	Current Range
3-6mm	60-100A
6-12mm	100-130A
12-20mm	130-165A
20mm+	165-260A

Work Angle

The work angle is the up and down of the electrode in relation to the angle of the joint. There are a few different joint types, and several positions these joints can be found.

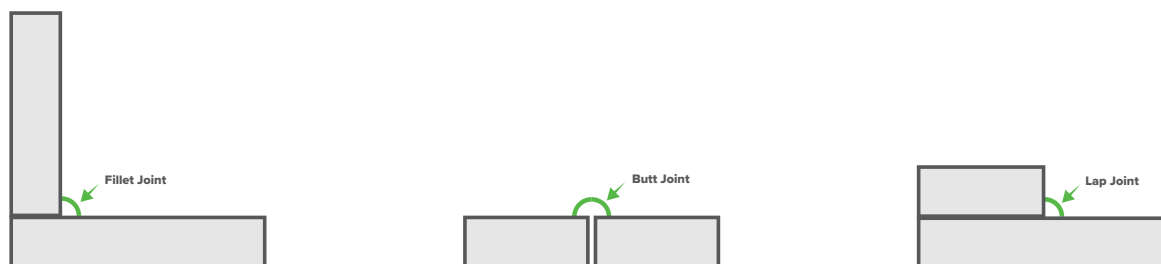

Fillet Joint (T-Joint)	Butt Joint	Lap Joint
90° joint angle	180° joint angle	90° joint angle
45° work angle	90° work angle	60-70° work angle

Travel Direction & Angle

When MMA welding, you only want to drag (pull) your weld. If you use a push angle, you risk having slag trapped in the weld pool and contaminating the weld. To drag your weld, place your electrode into the joint then tilt it slightly sideways by 10° to 15° . Your torch should hover over where you're going to be welding, rather than hovering over where you've already welded. When welding vertical up, the electrode should sit in the joint at roughly an 80° angle.

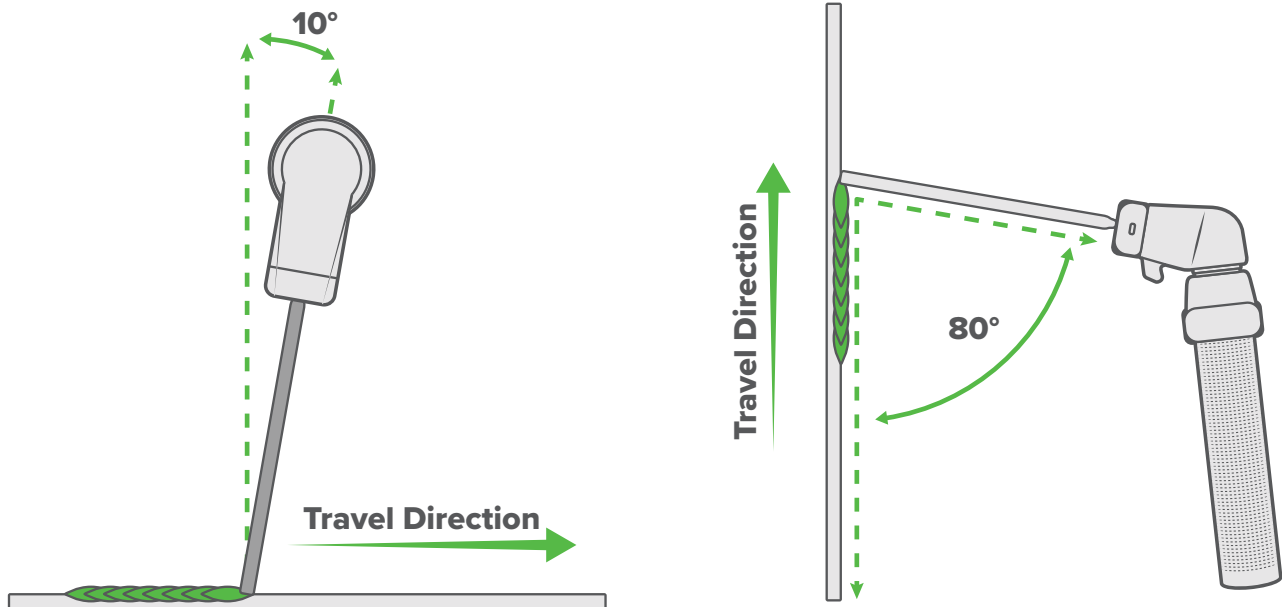

Arc Length

To strike the arc, the electrode should be gently scraped on the work until the arc is established. When welding, keep the arc length short. A good rule of thumb is that your arc length shouldn't be longer than your electrode diameter.

An arc too long reduces penetration, produces spatter and gives a rough surface finish to the weld. An excessively short arc will cause sticking of the electrode and result in poor quality welds.

Travel Speed

The electrode should be moved along in the direction of the joint being welded at a speed that will give the size of run required. At the same time, the electrode is fed downwards to keep the correct arc length at all times.

Travelling too fast will lead to poor fusion and a lack of penetration, while travelling too slow will frequently lead to arc instability, slag inclusions and burnthrough.

13. Welding Settings Guides

13.1 TIG Fillet

Rod dia.	Material	Shielding gas		Material Thickness (mm)													
				0.8	0.9	1	1.2	1.6	2	2.5	3	4	5	6	8	10	12
1.6mm	Mild steel	Ar100%	Amperage	40	45	55	65	70	80	90	100	115	125				
			Post-Flow	2s	2s	2s	2s	2s	2s	2s	2s	3s	4s	4s			
2.4mm	Mild steel	Ar100%	Amperage							100	110	120	130	140	145	150	160
			Post-Flow								2s	3s	4s	4s	4s	4s	4s
3.2mm	Mild steel	Ar100%	Amperage									130	135	145	155	160	170
			Post-Flow										4s	4s	4s	4s	4s
1.6mm	Stainless steel	Ar100%	Amperage	40	45	50	60	70	80	90	100	115	125				
			Post-Flow	2s	2s	2s	2s	2s	2s	2s	2s	3s	4s	4s			
2.4mm	Stainless steel	Ar100%	Amperage							100	110	120	130	140	145	150	160
			Post-Flow								3s	3s	4s	4s	4s	5s	4s
3.2mm	Stainless steel	Ar100%	Amperage									125	135	145	150	160	170
			Post-Flow										4s	4s	4s	5s	5s
1.6mm	Aluminium	Ar100%	Amperage	40	45	50	55	65	75	90	110						
			Post-Flow	2s	2s	2s	2s	3s	3s	3s	4s						
2.4mm	Aluminium	Ar100%	Amperage						80	95	110	125	140	160	180		
			Post-Flow							3s	3s	4s	4s	4s	5s	5s	
3.2mm	Aluminium	Ar100%	Amperage								120	125	140	160	180	200	210
			Post-Flow									4s	4s	4s	5s	5s	6s

13.2 TIG Butt

Rod dia.	Material	Shielding gas		Material Thickness (mm)													
				0.8	0.9	1	1.2	1.6	2	2.5	3	4	5	6	8	10	12
1.6mm	Mild steel	Ar100%	Amperage	35	40	40	45	50	65	75	85	100					
			Post-Flow	2s	2s	2s	2s	2s	3s	3s	3s	3s					
2.4mm	Mild steel	Ar100%	Amperage								85	100	115	130	140	155	170
			Post-Flow									3s	3s	3s	4s	4s	4s
3.2mm	Mild steel	Ar100%	Amperage									110	120	130	140	155	170
			Post-Flow										3s	3s	4s	5s	5s
1.6mm	Stainless steel	Ar100%	Amperage	35	40	40	45	50	65	75	85	100					
			Post-Flow	3s	3s	3s	3s	3s	3s	3s	3s	3s					
2.4mm	Stainless steel	Ar100%	Amperage								85	100	115	130	140	150	160
			Post-Flow									3s	3s	3s	4s	5s	5s
3.2mm	Stainless steel	Ar100%	Amperage									110	120	130	140	155	165
			Post-Flow										3s	3s	4s	5s	5s
1.6mm	Aluminium	Ar100%	Amperage			40	50	60	70	90	100						
			Post-Flow			2s	2s	3s	3s	3s	3s						
2.4mm	Aluminium	Ar100%	Amperage								110	125	140	150	160	180	200
			Post-Flow									3s	4s	5s	5s	5s	6s
3.2mm	Aluminium	Ar100%	Amperage								120	125	140	160	180	200	210
			Post-Flow									3s	4s	4s	5s	5s	6s

13.3 TIG Lap

Rod dia.	Material	Shielding gas		Material Thickness (mm)													
				0.8	0.9	1	1.2	1.6	2	2.5	3	4	5	6	8	10	12
1.6mm	Mild steel	Ar100%	Amperage	40	45	55	65	70	80	90	100	115	125				
			Post-Flow	2s	2s	2s	2s	2s	2s	2s	2s	3s	3s	4s			
2.4mm	Mild steel	Ar100%	Amperage							100	110	120	130	140	145	150	160
			Post-Flow								2s	3s	4s	4s	4s	4s	4s
3.2mm	Mild steel	Ar100%	Amperage									130	135	145	155	160	170
			Post-Flow										4s	4s	4s	4s	4s
1.6mm	Stainless steel	Ar100%	Amperage	40	45	50	60	70	80	90	100	115	125				
			Post-Flow	2s	2s	2s	2s	2s	2s	2s	2s	3s	3s	4s			
2.4mm	Stainless steel	Ar100%	Amperage							100	110	120	130	140	145	150	160
			Post-Flow								3s	3s	4s	4s	4s	5s	4s
3.2mm	Stainless steel	Ar100%	Amperage									125	135	145	150	160	170
			Post-Flow										4s	4s	4s	5s	5s
1.6mm	Aluminium	Ar100%	Amperage	40	45	50	55	65	75	90	110						
			Post-Flow	2s	2s	2s	2s	3s	3s	3s	3s						
2.4mm	Aluminium	Ar100%	Amperage						80	95	110	125	140	160	180		
			Post-Flow							3s	3s	3s	4s	4s	5s	5s	
3.2mm	Aluminium	Ar100%	Amperage								120	125	140	160	180	200	210
			Post-Flow									3s	4s	4s	5s	5s	6s

Settings Used

AC Wave	Square
Balance	35%
AC Frequency	120Hz

Recommended Tungsten Diameter

Diameter	Amperage Range
1.6mm	2-130A
2.4mm	30-200A
3.2mm	80-230A

i This setup information is intended to act as a guide only. Individual results may vary depending on technique, skill and material.

14. Gas Selection

14.1 TIG

Gas	Material Thickness (mm)															Thickness Range per Rod Diameter			
	1	2	3	4	5	6	7	8	9	10	11	12	13	14	15+	1.6mm	2.4mm	3.2mm	4.0mm
Ar 100%	Green	Green	Green	Green	Green	Green	Green	Green	Green	Green	Green	Green	White	White	White	Up to 5mm	2-12mm	4-12mm	5-12mm
Ar + 10-30% He	White	Green	Green	Green	Green	Green	Green	Green	Green	Green	Green	Green	Green	Green	White	2-6mm	3-13mm	5-14mm	6mm+
Ar + 50-75% He	White	White	Green	Green	Green	Green	Green	Green	Green	Green	Green	Green	Green	Green	Green	3-7mm	4-14mm	5-15mm	7mm+

i This setup information is intended to act as a guide only. Individual results may vary depending on technique, skill and material.

15. Welding Processes & Features Glossary

A

AC Balance - The ratio of positive to negative current in the AC cycle. Lower values increase penetration, while higher values increase cleaning action on the metal's surface.

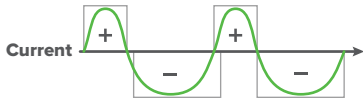

AC Frequency - The number of AC cycles in one second. A higher frequency narrows the arc for precision, while a lower frequency widens it for thicker materials.

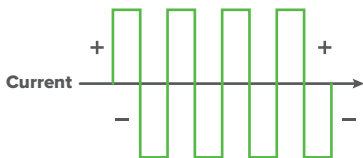

AC Waveform - The AC waveform determines the way the current flows between the positive and negative parts of the cycle. They affect the shape of the weld bead, penetration of the weld and the noise of the welding process. There are three waveforms to choose from: Square, Sine, Triangle, or a combination of two.

DC+	WAVEFORM	DC-
SINE		SINE
RECTANGULAR		RECTANGULAR
TRIANGULAR		TRIANGULAR
RECTANGULAR		SINE
SINE		RECTANGULAR
SINE		TRIANGULAR
TRIANGULAR		SINE
RECTANGULAR		TRIANGULAR
TRIANGULAR		RECTANGULAR

Amplitude Control - Amplitude Control adjusts the percentage of the AC waveform that is on the negative side for a more penetrative weld. Increasing the percentage of electrode negative puts more heat into the base plate, while decreasing the percentage of electrode positive reduces the amount of heat in the tungsten.

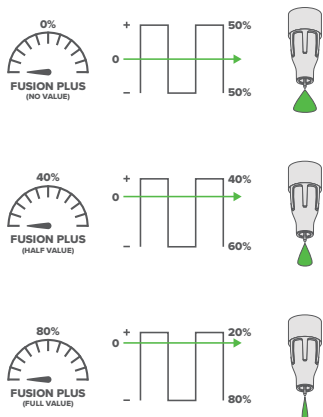

Arc Force - The level of current boost when the machine senses voltage drops, improving arc stability and preventing electrode sticking. A higher value gives a more forceful arc, especially useful in vertical or overhead positions.

B

Base Amp - The lower current level in the pulse cycle.

C

Cap Shaping - Automatically balls the tungsten end, eliminating manual preparation for enhanced efficiency.

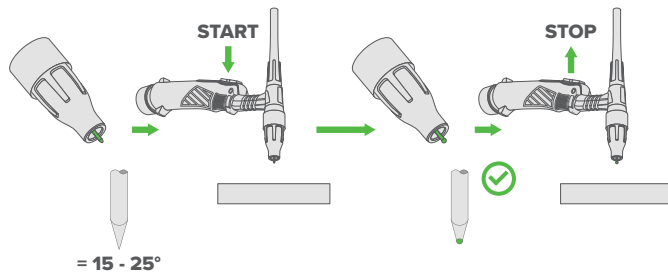

D

Diameter - Specify the diameter of your tungsten electrode.

Down Slope - The time the welding current takes to decrease from the main welding current to the End Amp.

E

End Amp - The final welding current value before the arc stops. A higher End Amp keeps more heat and ensures a smooth finish, while a lower End Amp reduces heat, minimising the chance of the weld warping or distorting.

H

HF TIG - High-frequency TIG is a non-contact method for arc initiation. Ensures a cleaner start by preventing tungsten contamination and reducing the risk of weld defects.

Hot Start - Hot Start boosts the initial welding current for a short duration to ensure a reliable arc start.

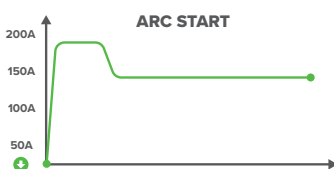

Hot Start Time - The time that the Hot Start current runs for.

L

Lift TIG - Lift Arc TIG is an arc ignition mode that initiates the arc by making brief contact between the tungsten and the workpiece. Once lifted, the arc continues without touching.

M

Mixed AC/DC - Combines the efficiency of AC TIG and the penetration of DC- TIG, designed specifically for aluminium. It achieves high welding speeds and quickly forms a weld puddle on cold workpieces, making it ideal

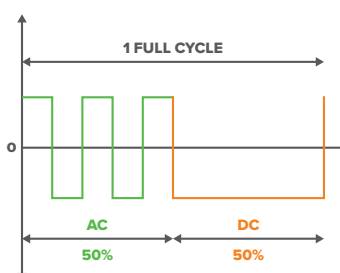

MMA - Manual Metal Arc (MMA) welding is an arc welding process in which an arc is formed between a flux-covered electrode and the base metal. The flux covering acts as a protective layer for the weld.

Min Amp - Sets the minimum amperage available on the machine when in a Remote Mode.

P

Peak Amp - The maximum current level during the weld. This also sets the peak in pulse cycle.

Pre-Gas - The duration of shielding gas released before the arc ignites. This ensures a protective environment, minimising contamination and improving weld quality.

Post-Gas - The duration of shielding gas released after the welding arc stops. This provides continued protection to the welded area, preventing oxidation and ensuring a cleaner weld finish.

Pulse - Alternates the welding current between a high and low value to aid in heat control and improve weld quality.

Pulse Frequency - The number of pulse cycles every second. Higher frequencies result in a more focused arc, while lower frequencies create a wider arc with more spread-out heat.

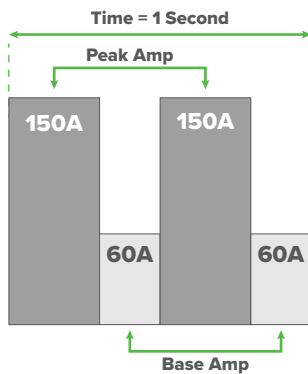

Pulse Width - The time the arc stays at its peak amperage during the pulse cycle. Wider widths mean more penetration, while narrower widths offer more heat control.

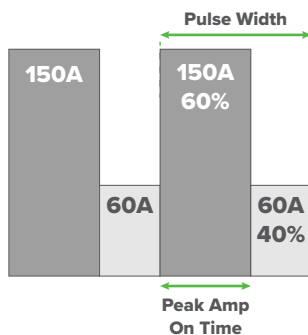

Purge - The Gas Purge function allows you to test and set the shielding gas flow rate. It also lets you back purge pipes and tubing being welded.

R

Remote Mode - Turn the remote control off or on for torch controls, wireless and wired foot pedals.

S

Smart TIG - The Smart-Set TIG mode is a set of synergic programs that guide the user through the selection of required parameters in an easily understandable way for the optimal settings on every job.

Speed Start - Speeds up the formation of the weld puddle by applying a synergic pulse program to the beginning of the weld. The initial pulse works to create the weld pool much faster than a standard start, as the vibration of the pulse speeds up the melting of the joint edges for quicker puddle formation.

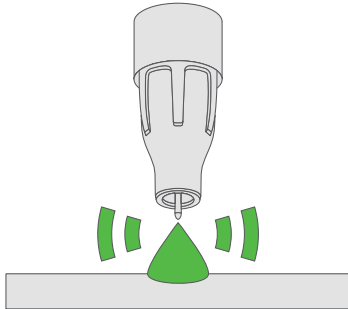

Recommended Speed Start Parameters		
Sheet Thickness (mm)	Current (A)	Speed Start Value (s)
1	35A - 50A	0.5 - 1.0
2	50A - 80A	0.5 - 1.0
3	80A - 140A	0.5 - 1.0
4	140A - 170A	0.5 - 1.0

Spot Mode - Spot Mode provides precision in creating timed weld spots with controlled intervals and counts. It's ideal for consistent tacking or producing uniform joins across materials.

Spot Time - The duration for each spot weld.

Start Amp - The amperage at the beginning of the welding process. A higher Start Amp provides a strong arc start, suitable for thicker materials, while a lower setting offers a gentler start for thin or sensitive materials.

Steady Arc - Steady Arc adjusts the welding current based on the arc voltage. When the voltage goes down, the amperage will go up, and vice versa, to give a consistent weld puddle, a sharper arc and a constant heat input. Weld speeds can be increased with no fluctuations in the weld current.

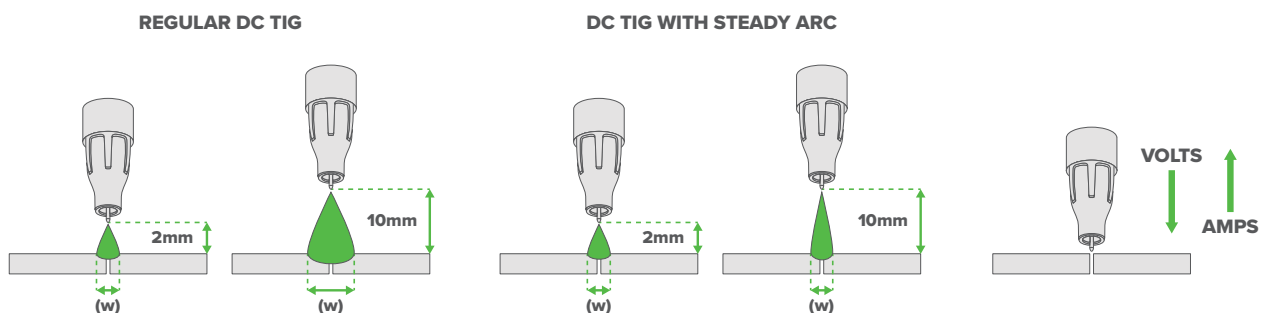

Recommended Steady Arc Parameters		
Sheet Thickness (mm)	Current (A)	Steady Arc (A)
1	35A - 50A	5 - 10
2	50A - 80A	10 - 15
3	80A - 140A	15 - 25
4	140A - 170A	25 - 50

T

TackPlus - TackPlus is a tack welding program used to create evenly spaced and sized fusion tack welds along a joint with minimal heat input.

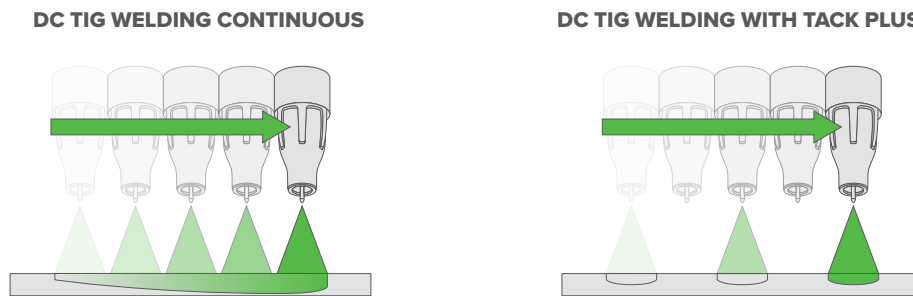

Recommended TackPlus Parameters		
Sheet Thickness (mm)	Current (A)	TackPlus Frequency (Hz)
0.6	40A - 60A	1.0 - 1.5
0.8	60A - 80A	1.0 - 1.5
1	80A - 100A	1.0 - 1.5
1.5	90A - 110A	1.0 - 1.5
2	110A - 130A	1.0 - 1.5
2.5	150A - 160A	1.0 - 1.5
	160A - 170A	1.5 - 2.0
3	170A - 180A	1.0 - 1.5
	180A - 200A	1.5 - 2.0

Trigger Mode 2T - Initiates welding when the torch trigger is pressed and stops when released.

Trigger Mode 4T - Press the torch trigger once to start welding and release it. Press again to stop the weld. This mode is useful for longer welds and reducing hand fatigue.

Trigger Mode HCT - Heat Control Trigger (HCT) lets you set a base current which you can switch to at any time during a weld by pressing the trigger button. Heat Control Trigger Mode is great for manual heat input control as you go.

U

Up Slope - The time the welding current takes to rise from the Start Amp to the main welding current. Longer up slope times ensure smoother transitions, reducing sudden heat input.

V

VRD - A Voltage Reduction Device is a safety device that reduces the open-circuit voltage of a welding machine. This minimises the risk of electric shock, especially in hazardous areas like enclosed or moist environments.

16. TIG Torch & Consumables

16.1 T2 TIG Torch

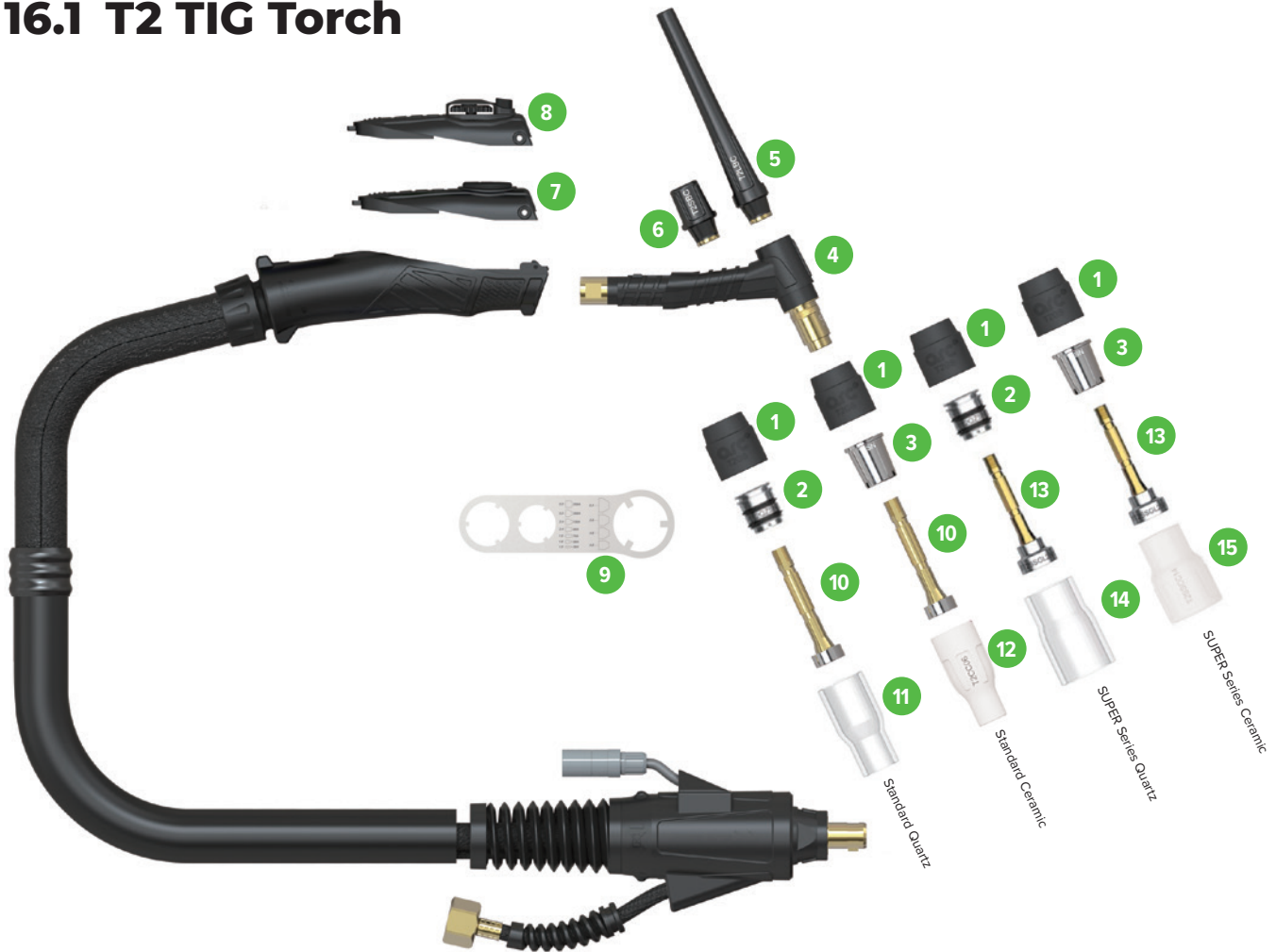

Length	4m	8m	4m (EURO)
SKU	UMT2F4M	UMT2F8M	UMT2F4ME

1	UMCT2HG	T2/T3W HEAD GASKET
2	UMCT2QZSN	T2/T3W QUARTZ ZONE ISOLATOR
3	UMCT2SN	T2/T3W HEAT ZONE ISOLATOR
4	UMCT2THF	T2 TORCH HEAD "FLEXIBLE HEAD"
	U42001	T2 TORCH HEAD - WP17 TORCH FLEX HEAD
	U42002	T2 TORCH HEAD - WP26 TORCH FLEX HEAD
5	UMCT2LBC	T2/T3W LONG BACK CAP
6	UMCT2SBC	T2/T3W SHORT BACK CAP
7	UMCTMS	1 BUTTON MOMENTARY
8	UMCTMK10KP	10K POTENTIOMETER
9	UMCTSPAN	SPANNER
10	See following page	GAS LENS COLLET BODY
11	See following page	QUARTZ CUP
12	See following page	CERAMIC CUP
13	See following page	SUPER SERIES GAS LENS COLLET BODY
14	See following page	SUPER SERIES QUARTZ CUP
15	See following page	SUPER SERIES CERAMIC CUP

COOLING METHOD	Air Cooled
DUTY CYCLE - DC	35% @ 190A
DUTY CYCLE - AC	35% @ 135A
LENGTHS (m)	4, 8
DINSE SIZE	35/50
ELECTRODE SIZE	1.0-4.0
STANDARD	EN60974-7

16.2 T2 TIG Torch Consumables

16.2.1 Standard TIG Setup

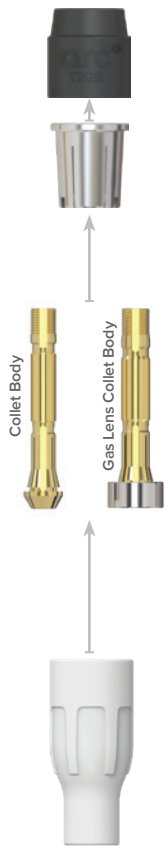

Head Gasket

UMCT2HG	HEAD GASKET SUIT T2/T3W QTY 1
----------------	-------------------------------

Heat Zone Isolator

UMCT2SN	HEAT ZONE ISOLATOR SUIT T2/T3W QTY 1
----------------	--------------------------------------

Collet Body / Gas Lens Collet Body

UMCT2CB10	COLLET BODY SUIT T2/T3W 1.0MM QTY 1
UMCT2CB16	COLLET BODY SUIT T2/T3W 1.6MM QTY 1
UMCT2CB24	COLLET BODY SUIT T2/T3W 2.4MM QTY 1
UMCT2CB32	COLLET BODY SUIT T2/T3W 3.2MM QTY 1
UMCT2GL10	GAS LENS COLLET BODY SUIT T2/T3W 1.0MM QTY 1
UMCT2GL16	GAS LENS COLLET BODY SUIT T2/T3W 1.6MM QTY 1
UMCT2GL24	GAS LENS COLLET BODY SUIT T2/T3W 2.4MM QTY 1
UMCT2GL32	GAS LENS COLLET BODY SUIT T2/T3W 3.2MM QTY 1

Ceramic Cups

UMCT2C04	CERAMIC CUP SUIT T2/T3W SIZE 4 6MM QTY 1
UMCT2C05	CERAMIC CUP SUIT T2/T3W SIZE 5 8MM QTY 1
UMCT2C06	CERAMIC CUP SUIT T2/T3W SIZE 6 10MM QTY 1
UMCT2C07	CERAMIC CUP SUIT T2/T3W SIZE 7 11MM QTY 1
UMCT2C08	CERAMIC CUP SUIT T2/T3W SIZE 8 12.5MM QTY 1
UMCT2C10	CERAMIC CUP SUIT T2/T3W SIZE 10 16MM QTY 1

16.2.2 Standard Quartz TIG Setup



Head Gasket

UMCT2HG	HEAD GASKET SUIT T2/T3W QTY 1
----------------	-------------------------------

Quartz Zone Isolator

UMCT2QZSN	QUARTZ ZONE ISOLATOR SUIT T2/T3W QTY 1
------------------	--

Collet Body / Gas Lens Collet Body

UMCT2GL10	GAS LENS COLLET BODY SUIT T2/T3W 1.0MM QTY 1
UMCT2GL16	GAS LENS COLLET BODY SUIT T2/T3W 1.6MM QTY 1
UMCT2GL24	GAS LENS COLLET BODY SUIT T2/T3W 2.4MM QTY 1
UMCT2GL32	GAS LENS COLLET BODY SUIT T2/T3W 3.2MM QTY 1

Quartz Cups

UMCT2QZ06	QUARTZ CUP SUIT T2/T3W SIZE 6 QTY 1
UMCT2QZ08	QUARTZ CUP SUIT T2/T3W SIZE 8 QTY 1
UMCT2QZ10	QUARTZ CUP SUIT T2/T3W SIZE 10 QTY 1
UMCT2C10	CERAMIC CUP SUIT T2/T3W SIZE 10 16MM QTY 1

16.2.3 SUPER Series Ceramic TIG Setup



Head Gasket

UMCT2HG	HEAD GASKET SUIT T2/T3W QTY 1
----------------	-------------------------------

Heat Zone Isolator

UMCT2SN	HEAT ZONE ISOLATOR SUIT T2/T3W QTY 1
----------------	--------------------------------------

SUPER Series Gas Lens Collet Body

UMCT2SSGL2016	GAS LENS COLLET BODY SUPER12 SUIT T2/T3W 1.6MM QTY 1
UMCT2SSGL2024	GAS LENS COLLET BODY SUPER12 SUIT T2/T3W 2.4MM QTY 1
UMCT2SSGL2032	GAS LENS COLLET BODY SUPER12 SUIT T2/T3W 3.2MM QTY 1
UMCT2SSGL2316	GAS LENS COLLET BODY SUPER14 SUIT T2/T3W 1.6MM QTY 1
UMCT2SSGL2324	GAS LENS COLLET BODY SUPER14 SUIT T2/T3W 2.4MM QTY 1
UMCT2SSGL2332	GAS LENS COLLET BODY SUPER14 SUIT T2/T3W 3.2MM QTY 1
UMCT2SSGL2816	GAS LENS COLLET BODY SUPER18 SUIT T2/T3W 1.6MM QTY 1
UMCT2SSGL2824	GAS LENS COLLET BODY SUPER18 SUIT T2/T3W 2.4MM QTY 1
UMCT2SSGL2832	GAS LENS COLLET BODY SUPER18 SUIT T2/T3W 3.2MM QTY 1

SUPER Series Ceramic Cups

UMCT2SSCC12	CERAMIC CUP SUPER12 SUIT T2/T3W SIZE 12 QTY 1
UMCT2SSCC14	CERAMIC CUP SUPER14 SUIT T2/T3W SIZE 14 QTY 1
UMCT2SSCC18	CERAMIC CUP SUPER18 SUIT T2/T3W SIZE 18 QTY 1

16.2.4 SUPER Series Quartz TIG Setup



Head Gasket

UMCT2HG	HEAD GASKET SUIT T2/T3W QTY 1
----------------	-------------------------------

Quartz Zone Isolator

UMCT2QZSN	QUARTZ ZONE ISOLATOR SUIT T2/T3W QTY 1
------------------	--

SUPER Series Gas Lens Collet Body

UMCT2SSGL2016	GAS LENS COLLET BODY SUPER12 SUIT T2/T3W 1.6MM QTY 1
UMCT2SSGL2024	GAS LENS COLLET BODY SUPER12 SUIT T2/T3W 2.4MM QTY 1
UMCT2SSGL2032	GAS LENS COLLET BODY SUPER12 SUIT T2/T3W 3.2MM QTY 1
UMCT2SSGL2316	GAS LENS COLLET BODY SUPER14 SUIT T2/T3W 1.6MM QTY 1
UMCT2SSGL2324	GAS LENS COLLET BODY SUPER14 SUIT T2/T3W 2.4MM QTY 1
UMCT2SSGL2332	GAS LENS COLLET BODY SUPER14 SUIT T2/T3W 3.2MM QTY 1
UMCT2SSGL2816	GAS LENS COLLET BODY SUPER18 SUIT T2/T3W 1.6MM QTY 1
UMCT2SSGL2824	GAS LENS COLLET BODY SUPER18 SUIT T2/T3W 2.4MM QTY 1
UMCT2SSGL2832	GAS LENS COLLET BODY SUPER18 SUIT T2/T3W 3.2MM QTY 1

SUPER Series Quartz Cups

UMCT2SSQZ12	QUARTZ CUP SUPER12 SUIT T2/T3W SIZE 12 QTY 1
UMCT2SSQZ14	QUARTZ CUP SUPER14 SUIT T2/T3W SIZE 14 QTY 1
UMCT2SSQZ18	QUARTZ CUP SUPER18 SUIT T2/T3W SIZE 18 QTY 1

17. Recommended Accessories



T2 Consumable Starter Kit
U42005



T2 SUPER Series Kit
U42006



Wireless Foot Pedal
U11100



Wired Foot Pedal
U11104



Machine Trolley
U11025



Water Cooler Module
U11026



T3W Water-Cooled TIG Torch
T3W-3KHL-4M

TIG Tungsten Electrodes



PTR0003-10	CERIATED TUNGSTEN GREY 1.0MM QTY 10
PTR0003-16	CERIATED TUNGSTEN GREY 1.6MM QTY 10
PTR0003-24	CERIATED TUNGSTEN GREY 2.4MM QTY 10
PTR0003-32	CERIATED TUNGSTEN GREY 3.2MM QTY 10
PTR0002-16	LANTHANATED TUNGSTEN GOLD 1.6MM QTY 10
PTR0002-24	LANTHANATED TUNGSTEN GOLD 2.4MM QTY 10
PTR0002-32	LANTHANATED TUNGSTEN GOLD 3.2MM QTY 10
PTR0005-16	RARE EARTH TUNGSTEN PURPLE 1.6MM QTY 10
PTR0005-24	RARE EARTH TUNGSTEN PURPLE 2.4MM QTY 10
PTR0005-32	RARE EARTH TUNGSTEN PURPLE 3.2MM QTY 10
PTR0004-10	THORIATED TUNGSTEN RED 1.0MM QTY 10
PTR0004-16	THORIATED TUNGSTEN RED 1.6MM QTY 10
PTR0004-24	THORIATED TUNGSTEN RED 2.4MM QTY 10
PTR0004-32	THORIATED TUNGSTEN RED 3.2MM QTY 10
PTR0006-10	ZIRCONIATED TUNGSTEN WHITE 1.0MM QTY 10
PTR0006-16	ZIRCONIATED TUNGSTEN WHITE 1.6MM QTY 10
PTR0006-24	ZIRCONIATED TUNGSTEN WHITE 2.4MM QTY 10
PTR0006-32	ZIRCONIATED TUNGSTEN WHITE 3.2MM QTY 10

TIG Welding Rods



AT4043-2.4-5	4043 TIG FILLER ROD 2.4MM 5KG
AT4043-3.2-5	4043 TIG FILLER ROD 3.2MM 5KG
AT5356-1.6-1KG	5356 TIG FILLER ROD 1.6MM 1KG
AT5356-1.6-5	5356 TIG FILLER ROD 1.6MM 5KG
AT5356-2.4-1KG	5356 TIG FILLER ROD 2.4MM 1KG
AT5356-2.4-5	5356 TIG FILLER ROD 2.4MM 5KG
AT5356-3.2-1KG	5356 TIG FILLER ROD 3.2MM 1KG
AT5356-3.2-5	5356 TIG FILLER ROD 3.2MM 5KG
TG102ER70S-2-1.6	ER70S-2-TIG FILLER ROD 1.6MM 5KG TRIPLE DEOXIDISED
TG102ER70S-2-2.4	ER70S-2-TIG FILLER ROD 2.4MM 5KG TRIPLE DEOXIDISED
TG4ER70S-4-1.6	ER70S-4-TIG FILLER ROD 1.6MM 5KG DOUBLE DEOXIDISED
TG4ER70S-4-2.4	ER70S-4-TIG FILLER ROD 2.4MM 5KG DOUBLE DEOXIDISED
TG2ER70S-6-1.6	ER70S-6-TIG FILLER ROD 1.6MM 5KG
TG2ER70S-6-2.4	ER70S-6-TIG FILLER ROD 2.4MM 5KG
TI308L-1.6	308L TIG FILLER ROD 1.6MM 5KG
TI308L-2.4	308L TIG FILLER ROD 2.4MM 5KG
TI309L-1.6	309L TIG FILLER ROD 1.6MM 5KG
TI309L-2.4	309L TIG FILLER ROD 2.4MM 5KG
TI316L-1.2	316L TIG FILLER ROD 1.2MM 5KG
TI316L-1.6-1	316L TIG FILLER ROD 1.6MM 1KG
TI316L-1.6	316L TIG FILLER ROD 1.6MM 5KG
TI316L-2.4-1	316L TIG FILLER ROD 2.4MM 1KG
TI316L-2.4	316L TIG FILLER ROD 2.4MM 5KG
TI316L-3.2	316L TIG FILLER ROD 3.2MM 5KG

MMA Welding Electrodes



U63028	HYPERARC NI 55 CAST IRON ELECTRODES - 2.6MM 1KG
U63029	HYPERARC NI 55 CAST IRON ELECTRODES - 3.2MM 1KG
U63026	HYPERARC NI 98 CAST IRON ELECTRODES - 2.6MM 1KG
U63027	HYPERARC NI 98 CAST IRON ELECTRODES - 3.2MM 1KG
U63025	HYPERARC 531 HARD FACING ELECTRODES - 3.2MM 1KG
U63014	HYPERARC 309L STAINLESS STEEL ELECTRODES - 2.6MM 2KG
U63015	HYPERARC 309L STAINLESS STEEL ELECTRODES - 3.2MM 2KG
U63017	HYPERARC 312L STAINLESS STEEL ELECTRODES - 2.6MM 1KG
U63019	HYPERARC 312L STAINLESS STEEL ELECTRODES - 2.6MM 2KG
U63018	HYPERARC 312L STAINLESS STEEL ELECTRODES - 3.2MM 1KG
U63020	HYPERARC 312L STAINLESS STEEL ELECTRODES - 3.2MM 2KG
U63021	HYPERARC 316L STAINLESS STEEL ELECTRODES - 2.6MM 1KG
U63023	HYPERARC 316L STAINLESS STEEL ELECTRODES - 2.6MM 2KG
U63022	HYPERARC 316L STAINLESS STEEL ELECTRODES - 3.2MM 1KG
U63024	HYPERARC 316L STAINLESS STEEL ELECTRODES - 3.2MM 2KG
U63006	HYPERARC 16TC LOW-HYDROGEN ELECTRODES - 2.6MM 1KG HANDY PACK
U63008	HYPERARC 16TC LOW-HYDROGEN ELECTRODES - 2.6MM 2KG
U63007	HYPERARC 16TC LOW-HYDROGEN ELECTRODES - 3.2MM 1KG HANDY PACK
U63009	HYPERARC 16TC LOW-HYDROGEN ELECTRODES - 3.2MM 2KG
U63010	HYPERARC 16TC LOW-HYDROGEN ELECTRODES - 4.0MM 2KG
U63002	HYPERARC 6013 GP ELECTRODES - 1KG HANDY PACK
U63030	HYPERARC 6013 GP ELECTRODES - 2.0MM 1KG HANDY PACK
U63031	HYPERARC 6013 GP ELECTRODES - 2.0MM 2.5KG
U63001	HYPERARC 6013 GP ELECTRODES - 2.6MM 1KG HANDY PACK
U63032	HYPERARC 6013 GP ELECTRODES - 2.6MM 2.5KG
U63003	HYPERARC 6013 GP ELECTRODES - 2.6MM 5KG
U63033	HYPERARC 6013 GP ELECTRODES - 3.2MM 2.5KG
U63004	HYPERARC 6013 GP ELECTRODES - 3.2MM 5KG
U63005	HYPERARC 6013 GP ELECTRODES - 4.0MM 5KG
U63011	HYPERARC 7018 LOW HYDROGEN ELECTRODES - 2.6MM 2KG
U63012	HYPERARC 7018 LOW HYDROGEN ELECTRODES - 3.2MM 2KG
U63013	HYPERARC 7018 LOW HYDROGEN ELECTRODES - 4.0MM 2KG

UNIMIG

B U I L T F O R W E L D E R S



100%
AUSTRALIAN
OWNED

unimig.com.au

    @UNIMIG