

UNIMIG ENVY



CUT 120/160

Contents

1. Safety	3
2. Input Power Requirements	7
2.1 Circuit Breaker Recommendation	8
2.2 Welding Cable Leads Recommendation	8
2.3 Extension Cord Data	9
2.4 Generator Power Data	9
3. Package Contents	10
4. Technical Specifications	11
4.1 ENVY CUT 120 Machine Specifications	11
4.2 ENVY CUT 160 Machine Specifications	11
4.3 Equipment Identification	12
4.4 Duty Cycle & Overheating	12
4.4.1 ENVY CUT 120	12
4.4.2 ENVY CUT 160	12
4.5 Pinout	13
5. Machine Overview	14
5.1 Key Features	14
5.2 Plasma Features	14
5.3 Machine Layout	15
5.3.1 ENVY CUT 120	15
5.3.2 ENVY CUT 160	16
6. Installation	17
6.1 Assembling the Plasma Torch	17
6.2 Connecting the Plasma Torch	20
6.3 Connecting the Earth Clamp	21
6.3.1 Connecting the Earth Clamp to the Workpiece	21
6.4 Connecting an External Air Compressor	22
6.5 Installing Additional Air Filters	23
6.6 Setting the Voltage Divider	24
6.6.1 ENVY CUT 120	24
6.6.2 ENVY CUT 160	25
6.7 Connecting the Plasma Cutter to a CNC Table (optional)	28
6.8 Assembling the CNC Plasma Torch	29
6.9 Connecting the CNC Torch (optional)	30
7. Operation	31
7.1 Preparing for Operation	31
7.2 Control Panel Layout & Operation	32
7.3 Cut Mode	33
7.3.1 Cutting Parameters	33
7.4 Smart-Set Cut Mode	34
7.4.1 Cutting Parameters	34
7.5 Job Menu	35
7.5.1 Saving a Job	35
7.5.2 Overwriting a Job	35
7.5.3 Importing a Job	35
7.5.4 Exporting a Job	35
7.5.5 Deleting a Job	36
7.6 Settings Menu	37
7.6.1 Welding Parameters	37
8. Maintenance	38
8.1 Maintaining the Consumables	39
9. Troubleshooting	40
9.1 Machine Troubleshooting	40
9.2 Plasma Troubleshooting	40
9.3 Error Codes	42
10. Plasma Cutting Guide	43
11. Plasma Cutting Processes & Features Glossary	51
12. Plasma Torch & Consumables	52
12.1 SC160 Plasma Torch	52
12.2 SC160 Plasma Torch Consumables	53
12.2.1 Gouging	53
12.2.2 Cutting	54
13. Recommended Accessories	55

1. Safety

Cutting equipment can be dangerous to both the operator and people in or near the surrounding working area if the equipment is not correctly operated. Equipment must only be used under the strict and comprehensive observance of all relevant safety regulations.

Read and understand this instruction manual carefully for all system components, especially the safety instructions and warning notices before the installation and operation of this equipment.

Product specifications and features are subject to change without notice. While every effort has been made to provide accurate and current information at the time of publication, this manual is intended as a general guide and is not exhaustive regarding safety, cutting, or the operation and maintenance of this unit. Due to the many variables in the welding field and the evolving nature of both the field and the UNIMIG product line, Welding Guns of Australia Pty Ltd. does not guarantee the accuracy, completeness, authority, or authenticity of the information in this manual or provided by any UNIMIG employee during conversations or business dealings. The product owner assumes all liability for its use and maintenance. Welding Guns of Australia Pty Ltd. does not warrant this product or this document for fitness for any particular purpose, performance, accuracy, or suitability of application. Furthermore, Welding Guns of Australia Pty Ltd. accepts no liability for injury or damages, whether consequential or incidental, resulting from the use of this product or from the content of this document, nor does it accept third-party claims of such liability.

Note:

- Observe the accident prevention regulations and any regional regulations.
- Safety and warning labels on the machine indicate any possible risks.
- Keep these labels clean and legible at all times.
- Technical changes due to further development in machine technology may lead to different welding behaviour.

Items in the manual that require particular attention in order to minimise damage and harm are indicated with the below symbols. Read these sections carefully and follow their instructions.

 **Note:** Gives the user a useful piece of information.

 **Caution:** Describes a situation that may result in damage to the equipment or system.

 **Warning:** Describes a potentially dangerous situation. If not avoided, it will result in personal damage or fatal injury.

Machine Operating Safety

- Do not switch the function modes while the machine is operating. Switching of the function modes during welding can damage the machine. Damage caused in this manner will not be covered under warranty.
- Only qualified persons should install, operate, maintain, and repair this equipment.
- During operation, keep everyone, especially children, away.



Electric Shock

Electric shock can kill. Touching live electrical parts can cause fatal shocks or severe burns. The electrode and work circuit is electrically live whenever the output is on. The input power circuit and internal machine circuits are also live when power is on. Incorrectly installed or improperly grounded equipment is dangerous.

- Connect the primary input cable according to Australian and New Zealand standards and regulations.
- Avoid all contact with live electrical parts of the cutting circuit, such as sockets and electrodes with bare hands.
- The operator must wear dry, hole-free welding gloves and body protection while they perform the cutting task.
- The operator should keep the workpiece insulated from themselves.
- Keep cords dry, free of oil and grease, and protected from hot metal and sparks.
- Frequently inspect input power cable for wear and tear, and replace the cable immediately if damaged. Bare wiring is dangerous and can kill.
- Do not use damaged, undersized, or badly joined cables.
- Do not cut in the rain or in wet, moist, or damp areas.
- Do not drape cables over your body.
- Disconnect power source before servicing or maintaining this equipment.
- We recommend an RCD safety switch is used with this equipment to detect any leakage of current to earth.

⚠ DC voltage remains in the inverter power source after the removal of input power.



Arc Rays

Arc rays are harmful to your eyes and skin. Arc rays from the cutting process produce intense visible and invisible ultraviolet and infrared rays that can burn eyes and skin.

- Always wear an approved welding helmet with the correct shade of filter lens and suitable protective clothing, including welding gloves, while the cutting operation is performed.

Recommended filter shades for plasma cutting

Less than 20 amps	4
20 to 40 amps	5
40 to 60 amps	6
60 to 80 amps	8
80 to 300 amps	8

**Use one shade darker for aluminium.*

- Wear safety glasses under your helmet.
- Measures should be taken to protect people in or near the surrounding working area. Use protective screens or barriers to protect others from flash, glare and sparks; warn others not to watch the arc.
- Wear proper PPE and body protection made from durable, flame-resistant materials like leather.

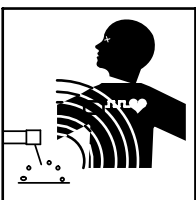

Electro Magnetic Fields (EMF)

Magnetic fields can affect Implanted Medical Devices.

- Wearers of Pacemakers and other Implanted Medical Devices should keep away.
- Implanted Medical Device wearers should consult their doctor and the device manufacturer before going near any plasma cutting.

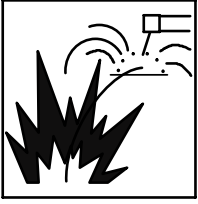

Fire Hazard

Cutting on closed containers, such as tanks, drums, or pipes, can cause them to explode. Flying sparks from the cutting arc, hot workpiece, and hot equipment can cause fires and burns. Accidental contact of the electrode with metal objects can cause sparks, explosions, overheating, or fire. Check and be sure the area is safe before doing any cutting.

- Remove any flammable materials well away from the working area. Cover flammable materials and containers with approved covers if they cannot be moved from the area.
- Do not cut on closed containers or containers that have held combustible materials, such as tanks, drums, or pipes, unless they are correctly prepared according to the required Safety Standards to ensure that flammable or toxic vapours and substances are totally removed, these can cause an explosion even though the vessel has been “cleaned”.
- Vent hollow castings or containers before cutting. They may explode.
- Do not cut where the atmosphere may contain flammable dust, gas, or liquid vapours (such as petrol).
- Have a fire extinguisher nearby and know how to use it.
- Be alert that cutting sparks and hot materials from cutting can easily go through small cracks and openings to adjacent areas.
- Be aware that cutting on a ceiling, floor, bulkhead, or partition can cause a fire on the hidden side.
- Avoid cutting on tyre rims or wheels, as heating can cause tyres to explode and repaired rims may fail.
- Attach the earth clamp as close as possible to the cutting area to minimise the risk of electric shock, sparks, and fire hazards caused by the cutting current travelling through long or unknown paths.
- Before cutting, remove any combustible items, like butane lighters or matches, from your person.
- Post cutting, thoroughly inspect the area to ensure there are no lingering sparks, glowing embers, or flames.
- Always use the correct fuses or circuit breakers, and don't oversize or bypass them.
- Wear proper PPE and body protection made from durable, flame-resistant materials like leather.
- Read and understand the Safety Data Sheets (SDSs) and the manufacturer's instructions for adhesives, coatings, cleaners, consumables, coolants, degreasers, fluxes, and metals.



Hot Parts

Hot parts can burn. Items being welded can generate and hold high heat and can cause severe burns.

- Do not touch hot parts with bare hands.
- Allow a cooling period before working on the welding equipment.
- Use the proper tools and insulated welding gloves and clothing to handle hot parts and prevent burns.



Noise Hazards

The noise from some processes or equipment can damage hearing.

- Wear approved ear protection if the noise level is high.



Fumes & Gases

Fumes and gases are dangerous. Welding produces fumes and gases and breathing these fumes and gases can be hazardous to your health.

- Do not breathe the smoke and gas generated while welding. Keep your head out of the fumes.
- Keep the working area well-ventilated and use fume extraction or ventilation to remove welding fumes and gases.
- In confined or heavy fume environments, always wear an approved air-supplied respirator.
- Welding fumes and gases can displace air and lower the oxygen level, causing injury or death. Be sure the breathing air is safe.
- Do not weld in locations near degreasing, cleaning, or spraying operations. The heat and rays of the arc can react with vapours to form highly toxic and irritating gases.
- Materials such as galvanised, lead, or cadmium-plated steel contain elements that can give off toxic fumes when welded. Do not weld these materials unless the coating is removed, or the area is very well-ventilated and/or you are wearing an air-supplied respirator.
- Read and understand the Safety Data Sheets (SDSs) and the manufacturer's instructions for adhesives, coatings, cleaners, consumables, coolants, degreasers, fluxes, and metals.

⚠ PLEASE NOTE that under no circumstances should any equipment or parts be altered or changed in any way from the standard specification without written permission given by UNIMIG.

To do so will void the warranty.

2. Input Power Requirements

UNIMIG plasma cutters are designed and manufactured to conform to **IEC 60974** or **AS 60974** standards. This Standard covers the safety and performance requirements of welding power sources and plasma cutting systems. This includes the **machine**, the **input cable**, and the **plug** requirements like the size of the plug that should be used.

Maximum effective supply current (I_{eff}) according to AS 60974.1

$$I_{\text{eff}} = \sqrt{I_1^2 \times X + I_0^2(1-X)}$$

- I_0 Rated no-load supply current
- I_1 Rated supply current
- X Rated duty cycle

The I_{eff} identifies the appropriate plug, input cable, and input current necessary for each device.

	Min-Max Cable Size
$I_{\text{eff}} \leq 10A$	1.5-2.5mm ²
$I_{\text{eff}} \leq 15A$	1.5-4.0mm ²
$I_{\text{eff}} \leq 25A$	2.5-6.0mm ²
$I_{\text{eff}} \leq 32A$	4.0-10.0mm ²

⚠ Don't risk damage to your machine or cause tripping and/or fire by using the wrong input current, cable or plug. Don't tamper with the plugs or file down earth pins. Doing so will void your warranty.

For your safety, UNIMIG meets the AS/NZS Standards for safe electrical compliance

All UNIMIG machines undergo an independent certification process to meet Australian and New Zealand regulations regarding electrical safety.



The triangle-circle-tick (RCM) symbol signifies that UNIMIG has taken the necessary steps to have the product comply with the electrical safety and/or electromagnetic compatibility (EMC) legislative requirements as specified by the Electrical Regulatory Authorities Council (ERAC). For your safety, please check for this symbol before buying any welding machine in Australia and New Zealand.

Check the rating plate on your machine

All welding machines that comply with **IEC 60974** or **AS 60974** must have a data plate similar to the one shown.

Welding machines draw some current when not welding, a higher current when welding, and a surge current when initiating an arc.

The effective rated primary current (I_{eff}) combines the conductor heating due to these levels of current. I_{eff} is the maximum rated effective supply current that determines the minimum plug and input cable rating as well as the minimum capacity of the input circuit that the machine gets plugged into to safely operate the machine.

Look for the I_{eff} on the welding machine's rating plate and ensure that you have the correct input circuit to support this power draw.

Example: If the I_{eff} rating on your machine is 27A then you must use a 32A plug, as a 15A plug is undersized for the welding current being used and may cause the cable to overheat.

UNIMIG				
ENVY CUT 160				
INVERTER DC PLASMA CUTTER	PART NO.	U11541		
	STANDARD	EN60974-1		
	$U_0=400V$	20A/88V-160A/144V		
	$U_1=415V$	X	60%	100%
		I_2	160A	125A
		U_2	144V	130V
	$U_1=415V$	$I_{1\text{max}}=42.4A$	$I_{\text{eff}}=32.9A$	
IP21S	H	AF	45.4Kg	

How important is the correct input cable and plug on a welding machine?

The size of the plug depends on the above formula, which uses the maximum current draw as well as the duty cycle of the power source. The use of any welding power source will not only cause the machine itself to heat up but the input cable, plug, and mains power as well.

That’s why it’s important to understand input and output currents and to make sure that the input circuit is correctly rated to supply the required input draw. This allows the machine to operate at or near maximum output and protects the circuit board from tripping, overheating and/or catching fire.

What if I don’t have a 415volt outlet?

If you don’t have a suitable power outlet, you should contact a qualified electrician to advise whether the wiring in your building will cater the necessary outlet. You may also need to upgrade your circuit breakers and possibly switchboard to suit. Failure to do this may cause an electrical fire in the building which may void insurances.

Make sure you:

- ✓ Use the correct input current cable and plug in accordance with **AS 60974.1** for your safety and to get the maximum performance from your plasma cutter.
- ✓ Inspect cables and plugs regularly.
- ✓ Contact a qualified electrician for advice and/or upgrade and, if needed, to replace any damaged plugs or cables.

2.1 Circuit Breaker Recommendation

The maximum input current (I_{max}) will determine the size of the circuit breaker that should be installed in order to run the machine continuously without risk of voltage drops from the circuit breaker to the plug outlet.

The recommended circuit breaker for this machine is 32A.

i This recommendation is distinct from the effective current (I_{eff}), which dictates the size of the input plug.

2.2 Welding Cable Leads Recommendation

Welding cables are crucial electrical conductors for the welding current. The appropriate thickness of the welding cable is dictated by the machine’s maximum amperage and the length of cable needed. It is essential that both the earth clamp and the electrode holder are equipped with adequately sized welding cable leads to maintain effective operation.

Current (A)	Duty Cycle (%)	Lead thickness (mm ²) based off combined lengths of electrode and earth cable				
		Up to 15m	16-30m	31-45m	46-60m	61-75m
125	30	10	16	25	35	50
150	40	10	16	25	35	50
180	30	25	25	35	50	50
200	60	35	35	35	50	50
225	30	25	25	50	50	50
250	30	25	25	50	50	50
275	60	50	50	50	70	95
300	60	50	50	70	70	95
350	60	50	50	70	95	120
400	100	70	70	95	95	120
500	100	70	95	95	95	120

2.3 Extension Cord Data

Always use an extension cord with a wire size that matches the cord length and the system voltage. The cord must comply with both national and local electrical standards.

For ENVY CUT 120 & 160 models, a three-phase extension cord between 3 and 45 metres should use a wire size of 10 mm² (8 AWG).

Using an extension lead that is too small, or using it over a longer distance than recommended, will lead to voltage drops and cause problems with power supply.

2.4 Generator Power Data

Operate this unit only with clean power generators that provide a surge capacity of 26,000 watts or more for the ENVY CUT 120 and 40,000 watts or more for the ENVY CUT 160.

The generator should limit Total Harmonic Distortion (THD) to 5% or below, as this level of THD is deemed 'clean' and comparable to conventional shop power. Usage of generators that don't meet the clean power standard (5% or lower THD) is not recommended.

⚠ Not following these recommendations can cause insufficient power, which can lead to unstable arc behaviour and poor weld quality. In some instances it can also cause damage to your equipment.

3. Package Contents

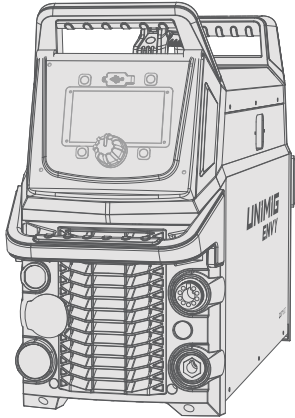

**ENVY CUT 120/160
Plasma Cutter**

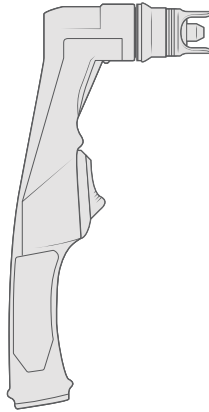

SC160 Plasma Torch

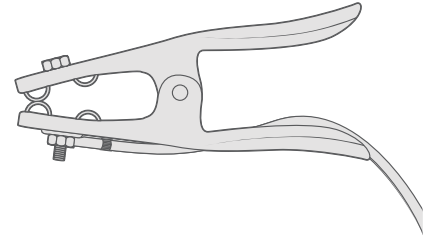

300A Earth Clamp

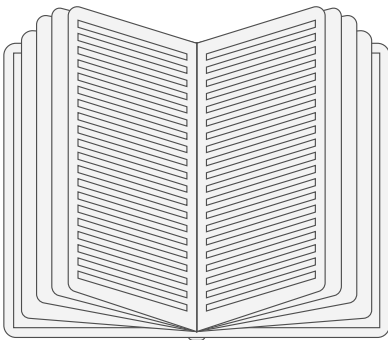

Manual

4. Technical Specifications

4.1 ENVY CUT 120 Machine Specifications

Technical Data

Parameter	Values
SKU	U11540
Primary Input Voltage	415V Three-Phase
Supply Plug	32A
I _{eff} (A)	27.5
I _{max} (A)	27.5
Rated Output (A)	20-120
No Load Voltage (V)	402
Protection Class	IP21S
Insulation Class	H
Minimum Generator (kVA)	26
Air Supply	Clean, dry, oil-free compressed air
Air Flow Draw (L/min)	140-330
Air Flow Pressure	43.5-101.5psi 3-7bar 0.3-0.7MPa
Recommended Compressor Output	400-450L/min FAD or higher
Dinse Connector	35/50
Standard	AS 60974.1
Warranty (Years)	5

Plasma Specifications

Parameter	Values
Plasma Cut Current Range (A)	20-120
Plasma Cut Duty Cycle @ 40°C	100% @ 120A
Mild Steel Cut Thickness	50mm
Mild Steel Severance Thickness	70mm
Stainless Cut Thickness	45mm
Aluminium Cut Thickness	40mm
Copper Cut Thickness	25mm

Size & Weight

Parameter	Values
Dimensions (mm)	810x280x520mm
Weight (kg)	39.2kg

4.2 ENVY CUT 160 Machine Specifications

Technical Data

Parameter	Values
SKU	U11541
Primary Input Voltage	415V Three-Phase
Supply Plug	32A
I _{eff} (A)	32.9
I _{max} (A)	42.4
Rated Output (A)	20-160
No Load Voltage (V)	400
Protection Class	IP21S
Insulation Class	H
Minimum Generator (kVA)	40
Air Supply	Clean, dry, oil-free compressed air
Air Flow Draw (L/min)	140-330
Air Flow Pressure	43.5-101.5psi 3-7bar 0.3-0.7MPa
Recommended Compressor Output	400-450L/min FAD or higher
Dinse Connector	35/50
Standard	AS 60974.1
Warranty (Years)	5

Plasma Specifications

Parameter	Values
Plasma Cut Current Range (A)	20-160
Plasma Cut Duty Cycle @ 40°C	60% @ 160A 100% @ 100A
Mild Steel Cut Thickness	65mm
Mild Steel Severance Thickness	80mm
Stainless Cut Thickness	60mm
Aluminium Cut Thickness	50mm
Copper Cut Thickness	35mm

Size & Weight

Parameter	Values
Dimensions (mm)	810x280x520mm
Weight (kg)	45.4kg

4.3 Equipment Identification

Serial Number

The serial number of the device is marked below the data plate on the underside of the machine. It is important to make correct reference to the serial number of the product when ordering spare parts or making repairs, for example.

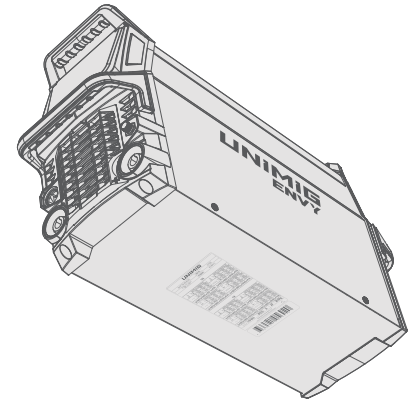

4.4 Duty Cycle & Overheating

The duty cycle is how long a machine can continuously weld at a selected amperage over a 10-minute period before the thermal overload protection kicks in.

4.4.1 ENVY CUT 120

Plasma - 100% @ 120A, at 40°C ambient temperature



4.4.2 ENVY CUT 160

Plasma - 60% @ 160A, at 40°C ambient temperature



4.5 Pinout

Plasma Torch Pinout



Pin	Function
1, 2	Trigger
5, 6	Pilot arc
8, 9	Safety

CNC Port Pinout (14 Pin)

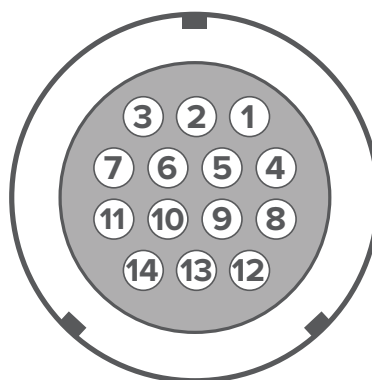

Pin	Function
1 (+), 2 (-)	1:1 Arc voltage feedback
3, 4	Switch
5 (-), 6 (+)	Adjustable arc voltage feedback
13	Earth cable
12, 14	Pilot arc state

5. Machine Overview

5.1 Key Features

5" Colour LCD Touchscreen

Change settings with ease with the intuitive touchscreen controls and next-generation user interface.

Smart Fan

Smart Fan diminishes noise, saves power, helps reduce energy costs, and minimises the number of contaminants being pulled through the machine.

Job Memory

The job memory function allows you to enter and store cut parameter settings. Cut parameters can be further adjusted and stored as required. A total of 100 Jobs can be memorised and stored for recall.

Generator Compatible

Going off the grid? The ENVY CUT 120 & 160 can be connected to a generator. We recommend one with at least 26kVA for the ENVY CUT 120 and 40kVA for the ENVY CUT 160.

IP21S Rating

Rated IP21S, so it's protected from touch by fingers and objects greater than 12mm, and water spray from a vertical direction.

Digital Air Pressure Regulation

Set and forget. The ENVY CUT 120 & 160 feature a built-in digital air pressure regulator that automatically adjusts the output pressure based on your selected cutting mode. This ensures optimal performance across all processes without needing manual pressure adjustments, giving you consistent results with every cut.

5.2 Plasma Features

Smart-Set Programs

The easiest way to set up for a plasma cut, simply select your cutting type, material type and thickness, and you're good to go!

CNC Connectivity

Not just a handheld plasma cutter, the CNC connection lets you plug in a CNC torch and run it on a CNC table, so you can choose how you use it.

Perforated Cut Mode

Get unrivalled performance across every kind of metal. With the perforated cutting mode, you can cut materials like grating or mesh without interruption, so you're not limited to solid plates.

Gouging Mode

Remove metal with precision and ease. Switch to gouging mode to cleanly remove welds, defects, or unwanted material without grinding and preserve more of your original workpiece.

Pilot Arc Start

Start your arc on any surface: painted, greasy, or rusted, or don't start on the surface at all. A pilot arc start will ignite the arc even from a short distance away, giving you better control and longer-lasting consumables.

2T/4T Trigger Modes

Easily swap between torch modes, so you stay comfortable no matter the length of the cut.

2T: (two touch) means you need to hold the trigger down on your torch while you cut. Releasing the trigger will end the cut.

4T: (four touch) means you only need to press the trigger to ignite the arc and the torch will continue to cut until you press it again to turn it off.

Air Test

The Air Test feature lets you test the air pressure before proceeding with cutting, to easily check you've set the optimal parameters.

5.3 Machine Layout

5.3.1 ENVY CUT 120

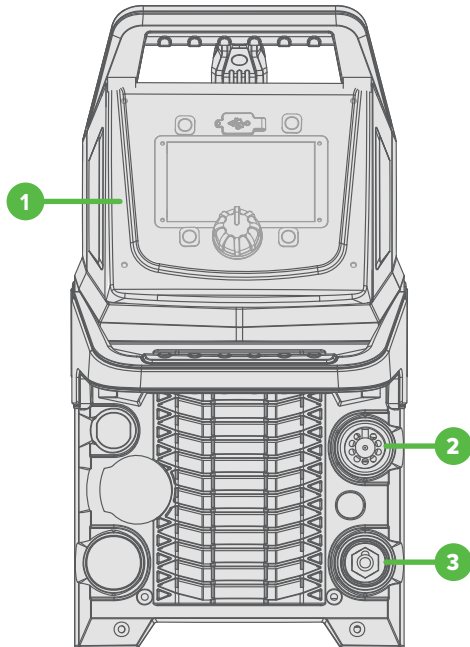

Front Panel Layout

1. Display Panel
2. Plasma Central Connection
3. Dinse Connector

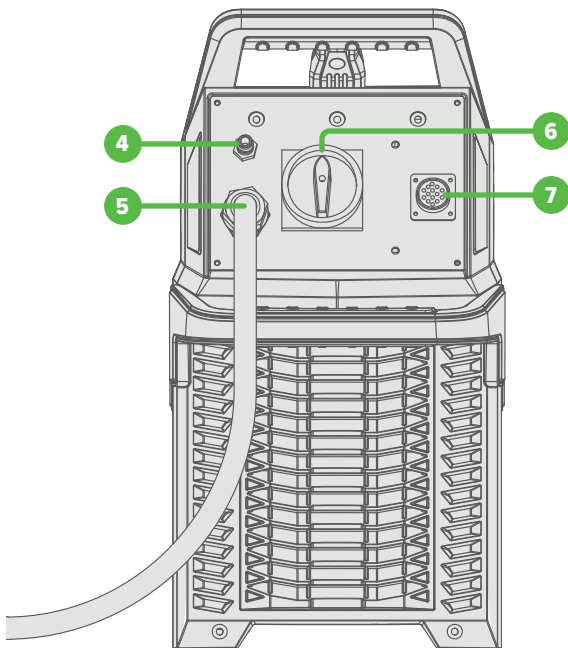

Back Panel Layout

4. Air Inlet (1/4" Nitto Fitting)
5. Power Cable
6. Power Switch
7. 14 Pin Control Outlet

5.3.2 ENVY CUT 160

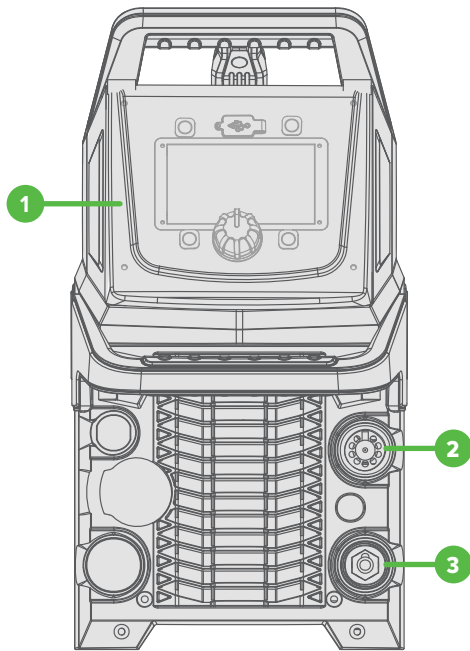

Front Panel Layout

- 1. Display Panel
- 2. Plasma Central Connection
- 3. Dinse Connector

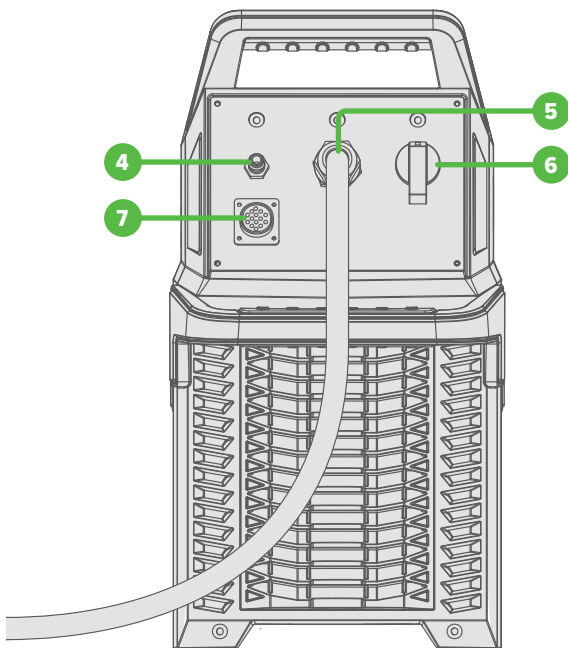

Back Panel Layout

- 4. Air Inlet (1/4" Nitto Fitting)
- 5. Power Cable
- 6. Power Switch
- 7. 14 Pin Control Outlet

6. Installation

⚠ Don't connect the equipment to the wall socket/mains supply before the installation is complete.

⚠ Don't modify the equipment in any way except for the changes and adjustments covered in the manufacturer's instructions.

i Place the machine on a horizontal, stable and clean ground. Check that there is enough space for cooling air circulation in the machine's vicinity. Don't cover the machine's ventilation as it could overheat.

6.1 Assembling the Plasma Torch

1. Screw the electrode into the torch head. Fasten securely.

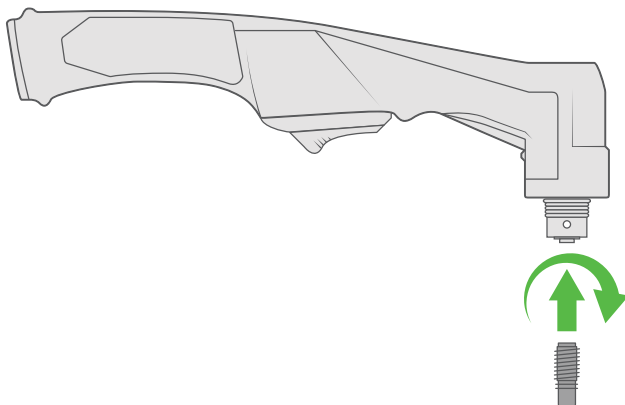

2. Place the swirl ring onto the electrode.

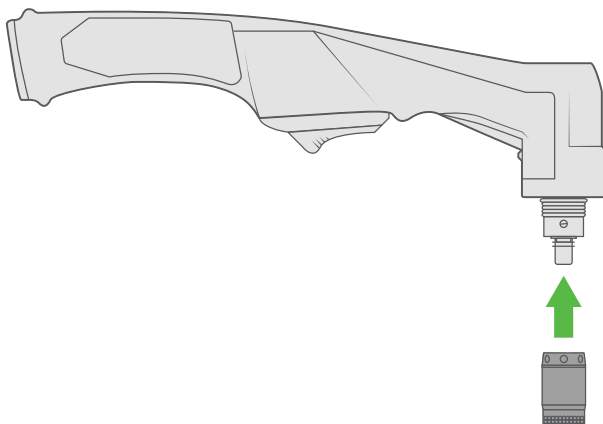

3. Place the cutting tip onto the swirl ring.

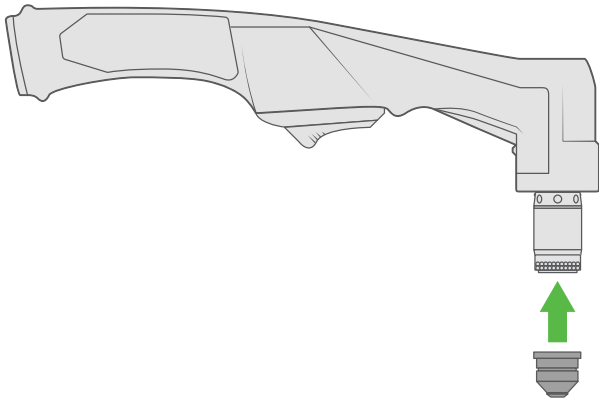

3. a) For gouging, place the gouging tip onto the swirl ring.

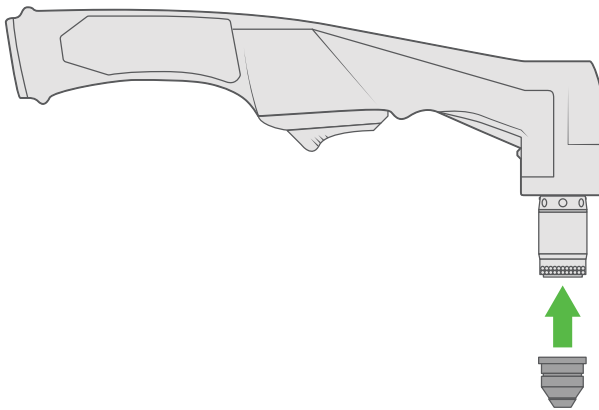

4. Screw the shield cap body onto the torch head. Fasten securely.

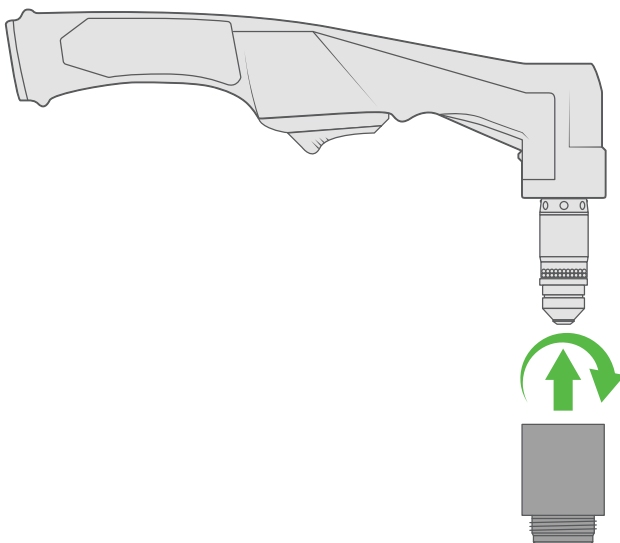

5. Screw the shield cap onto the shield cap body. Fasten securely.

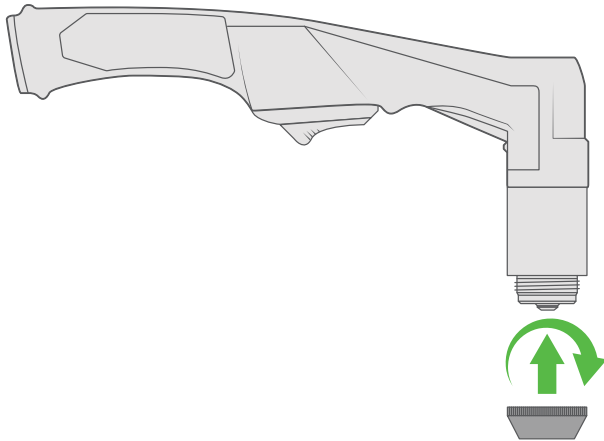

5. a) For gouging, screw the gouging shield cap onto the shield cap body.

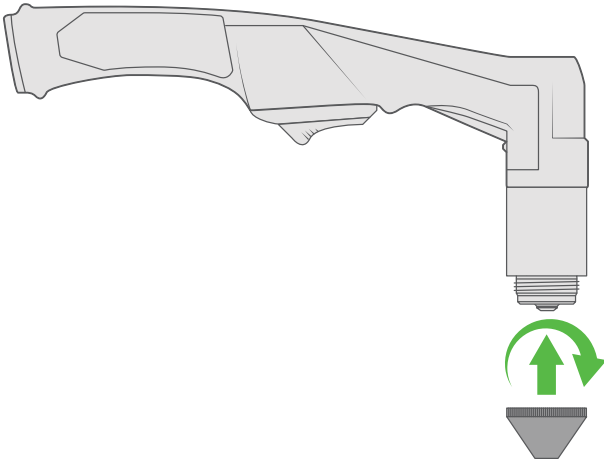

5. b) For circle cutting, place the cutting guide onto the shield cap.

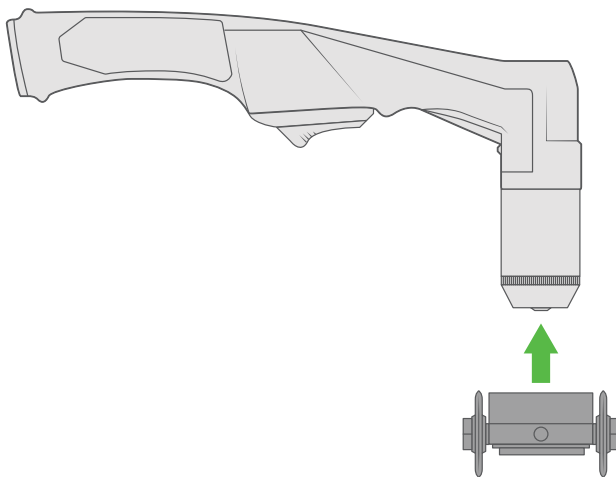

6.2 Connecting the Plasma Torch

1. Assemble the plasma torch.
2. Connect the plasma torch into the Plasma central connection.

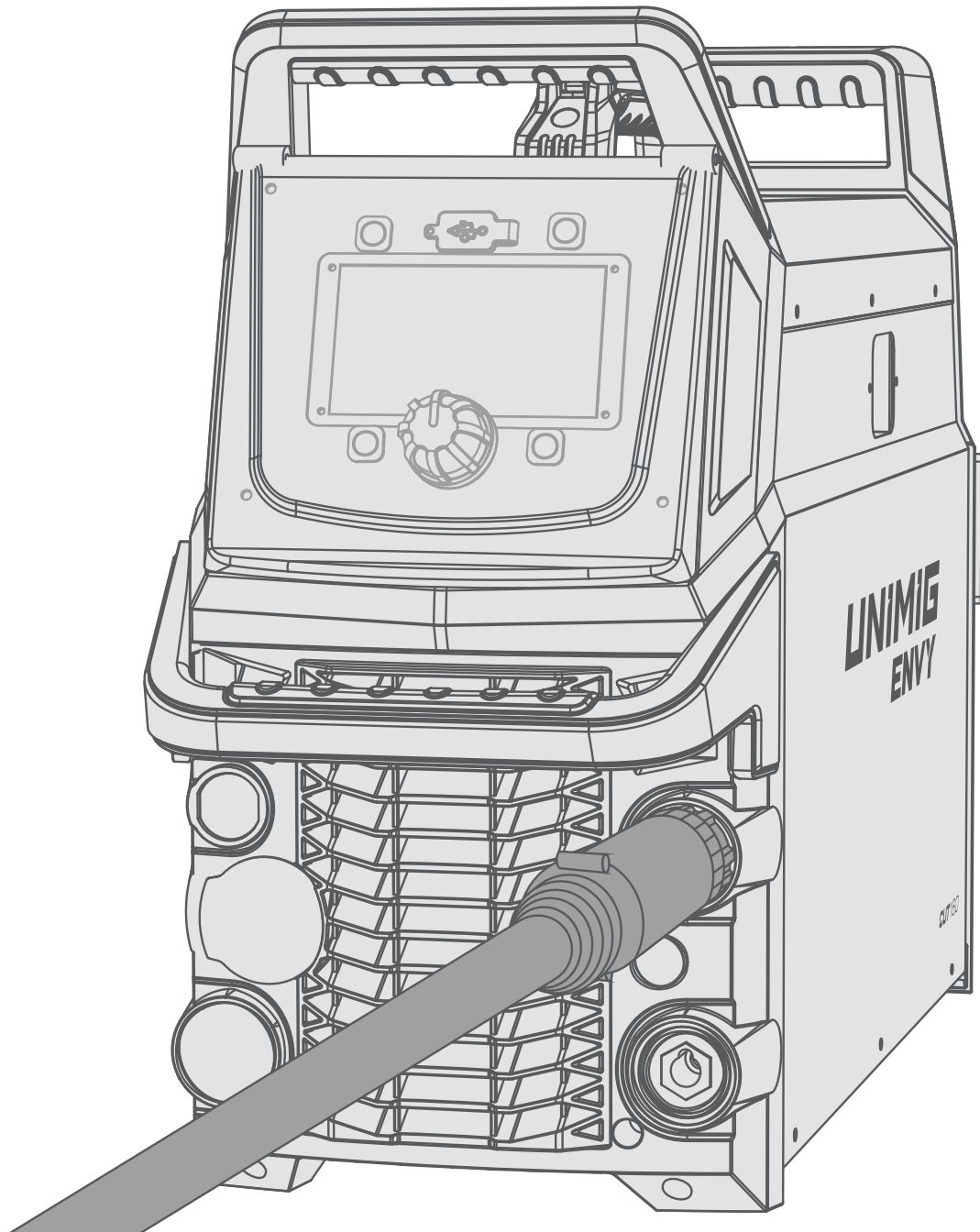

6.3 Connecting the Earth Clamp

Connect the earth clamp to the dinse connection.

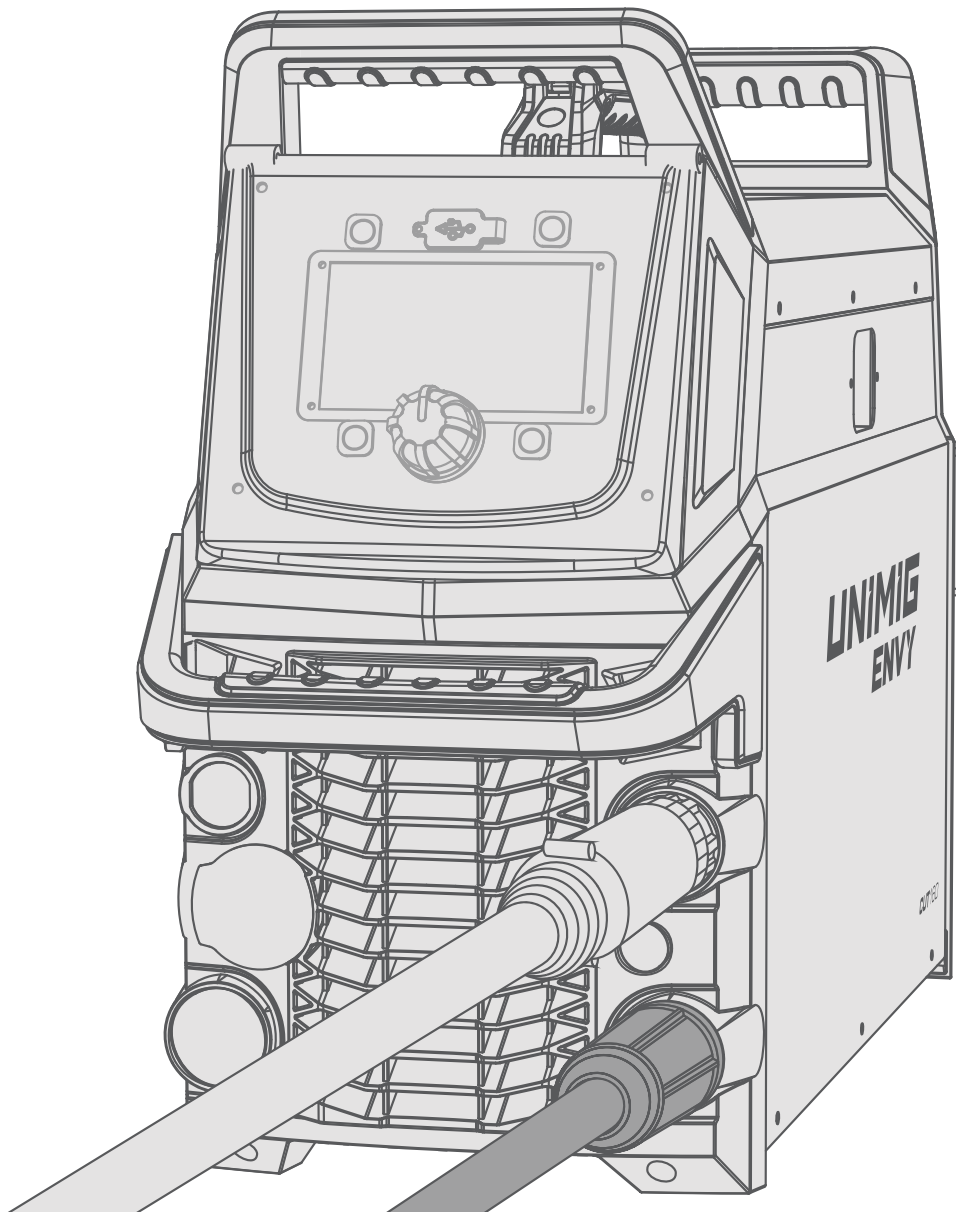

6.3.1 Connecting the Earth Clamp to the Workpiece

Ensure that the earth clamp has proper metal-to-metal contact with the workpiece by removing any rust, dirt, paint, coatings, or other debris.

i For the best cut quality, attach the earth clamp as close as possible to the area being cut.

i When using the machine with a cutting table, connect the earth clamp directly to the table rather than attaching it to the workpiece.

⚠ Don't place the earth clamp on the part of the workpiece that's going to be cut away.

6.4 Connecting an External Air Compressor

i The air compressor will need to have a minimum airflow draw that matches the plasma cutter's. It is recommended to get an air compressor with an additional 20% capability to eliminate bottlenecking and airflow issues.

1. Connect the air compressor to the back of the plasma cutter. The machine has a ¼" Nitto fitting.
2. Set the air pressure on the compressor. It is recommended to set the air pressure slightly higher than the plasma cutter's to allow for any drops in pressure depending on the hose length.

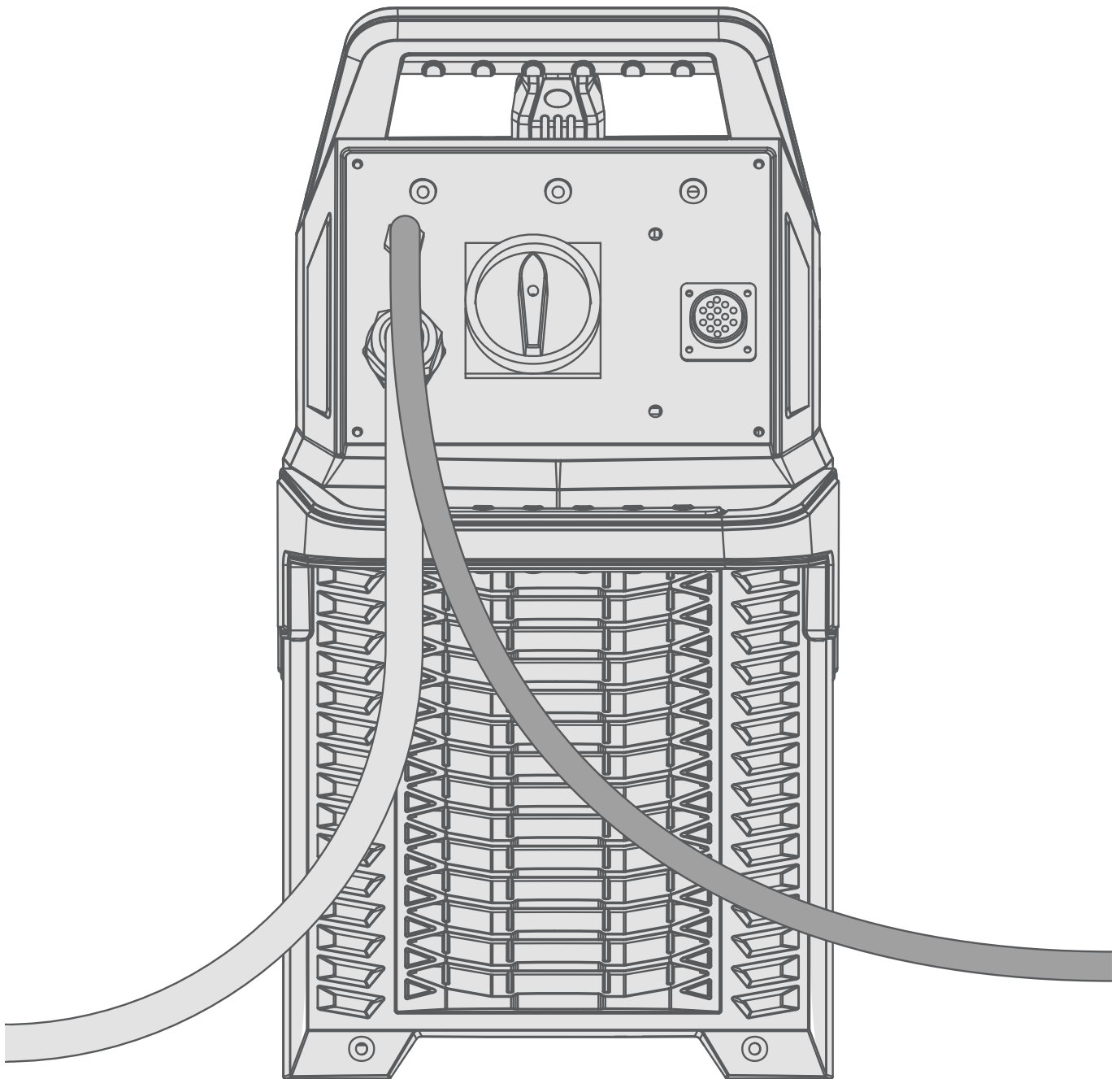

6.5 Installing Additional Air Filters

i If the supplied air quality is poor or there is moisture present, the cut speeds, cut quality, and thickness capabilities all decrease, and the life of the consumables shortens. To avoid these issues, install an (optional) additional air filtration system.

i Additional air filters should be installed between the air supply and the plasma cutter.

1. Connect the filter to the air hose.
2. Connect the filter to the plasma cutter via a second air hose.

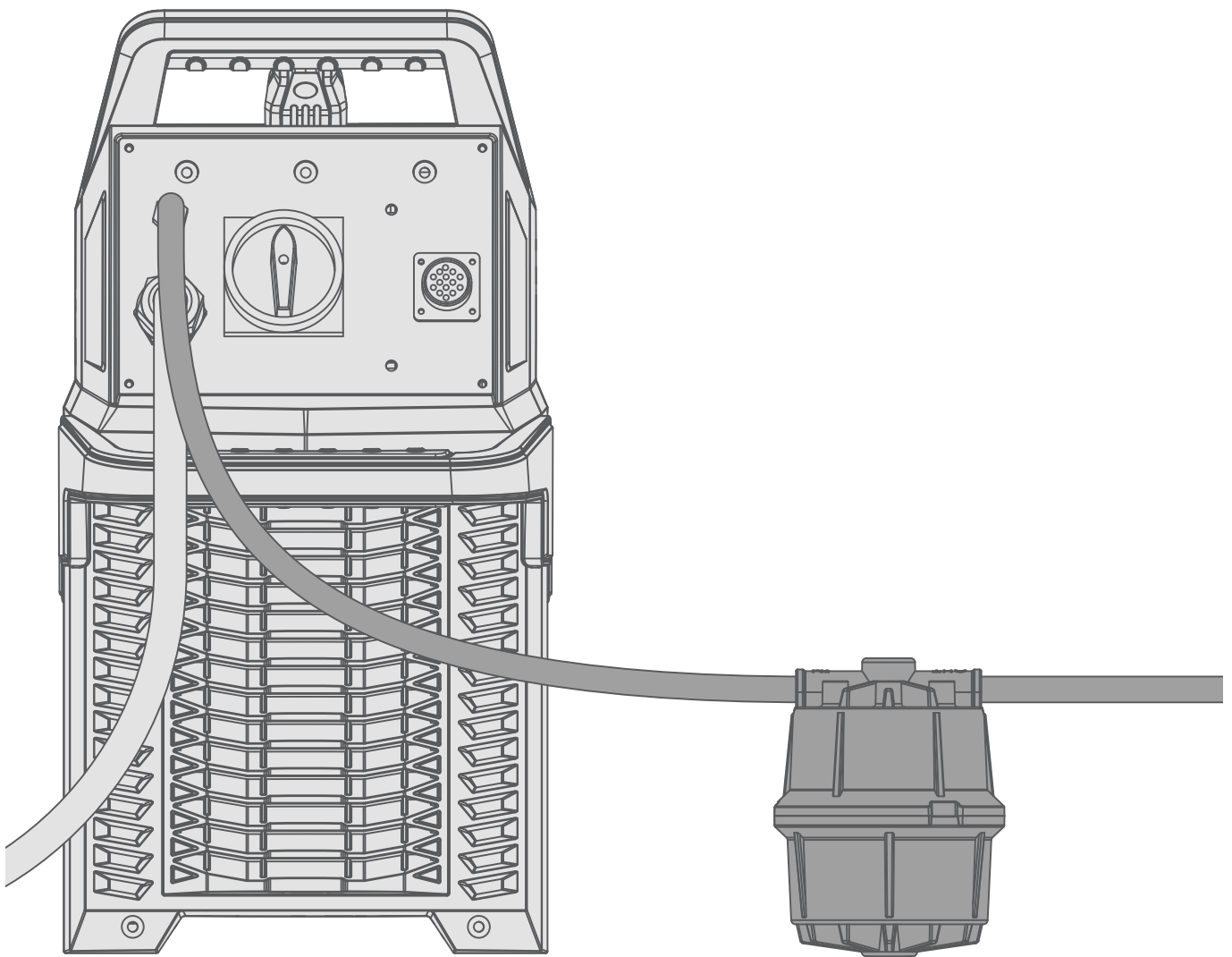

6.6 Setting the Voltage Divider

6.6.1 ENVY CUT 120

1. Remove the left side cover on the machine (when looking at the front of the machine).
2. Locate the voltage divider DIP switches. They are situated towards the top middle of the machine.

i The figure below shows the default setting (20:1) with the number 1 & 2 switches OFF.

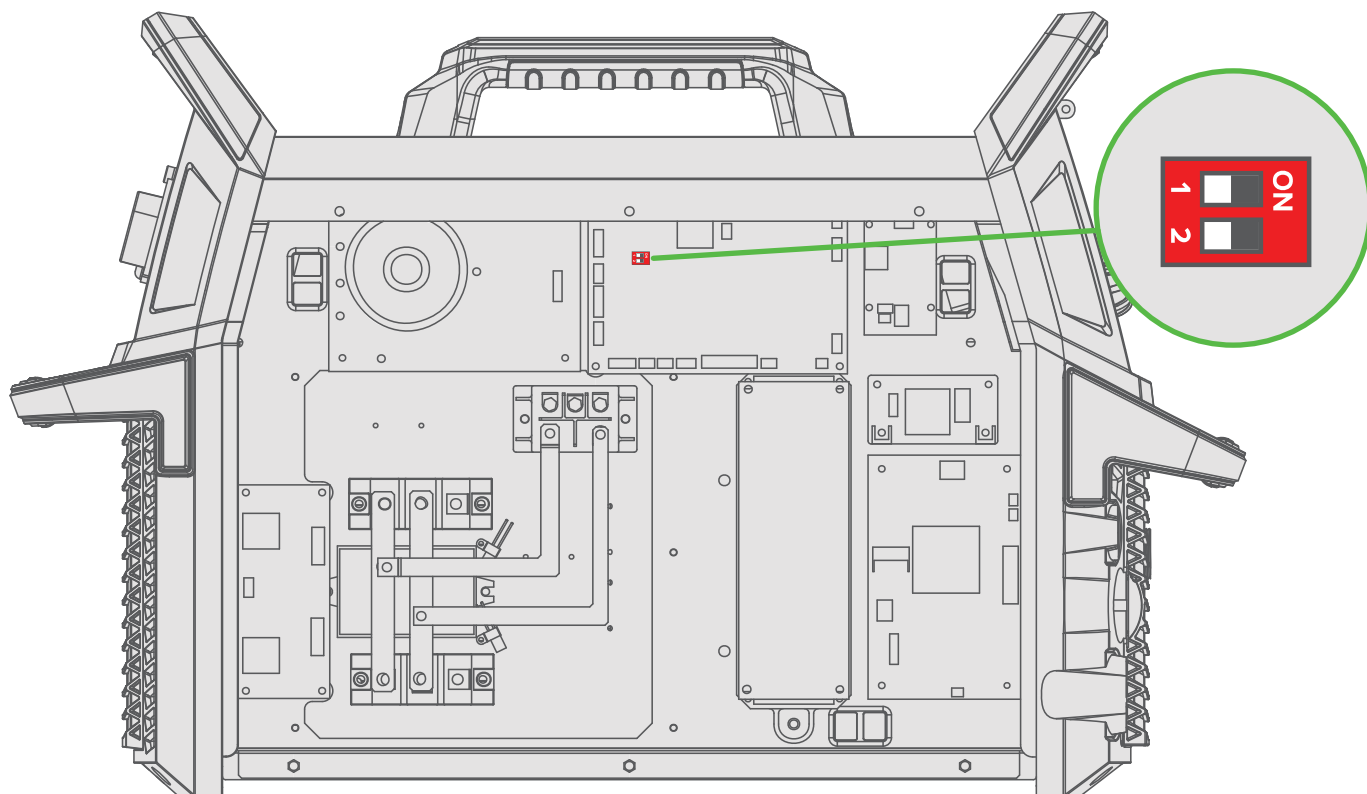

3. Set the DIP switches to one of the following settings and replace the machine cover.

50:1

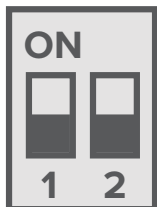

40:1

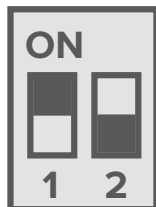

30:1

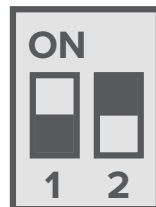

20:1

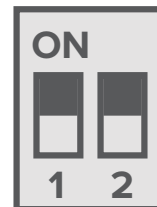

i For 1:1 voltage ratio, use pins 1 & 2 on the CNC Port.

6.6.2 ENVY CUT 160

Removing the Top Cover

1. Remove the 4 screws holding in the display panel of the machine.

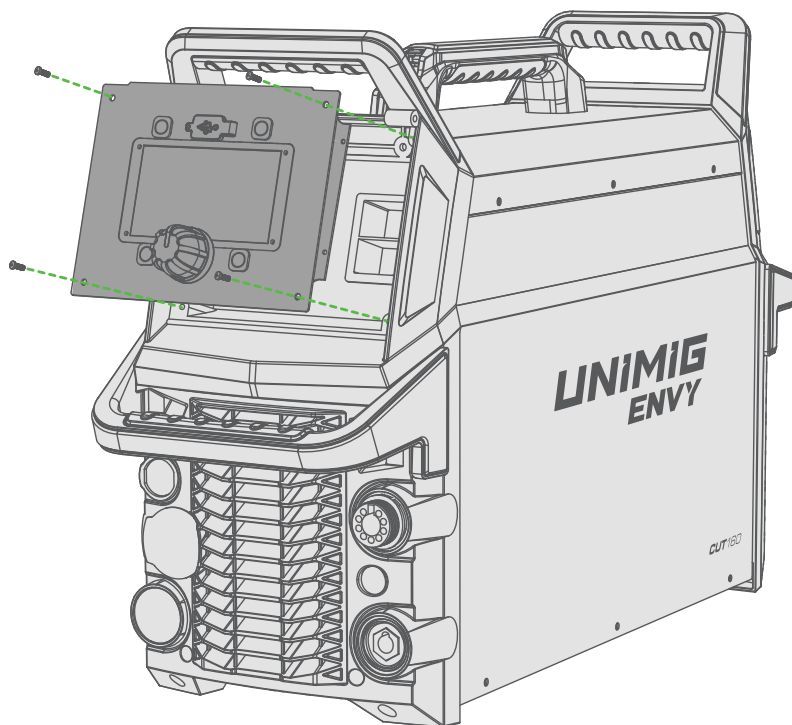

⚠ Be careful when removing the display panel as there are wires behind it connecting it to the machine internals.

2. Remove the 3 screws behind the display panel of the machine.

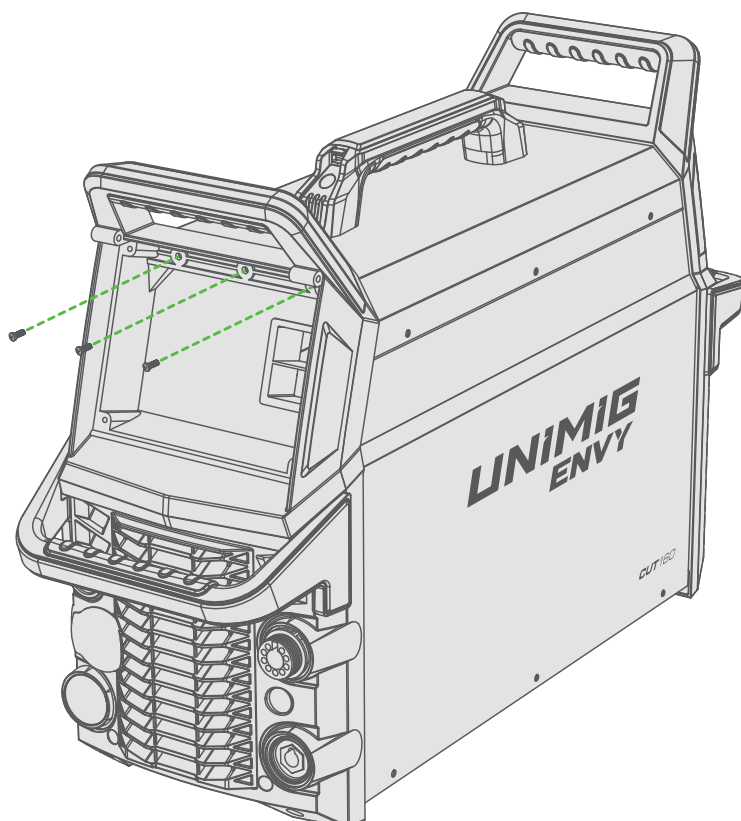

3. Remove the 3 screws at the top of the back panel of the machine.

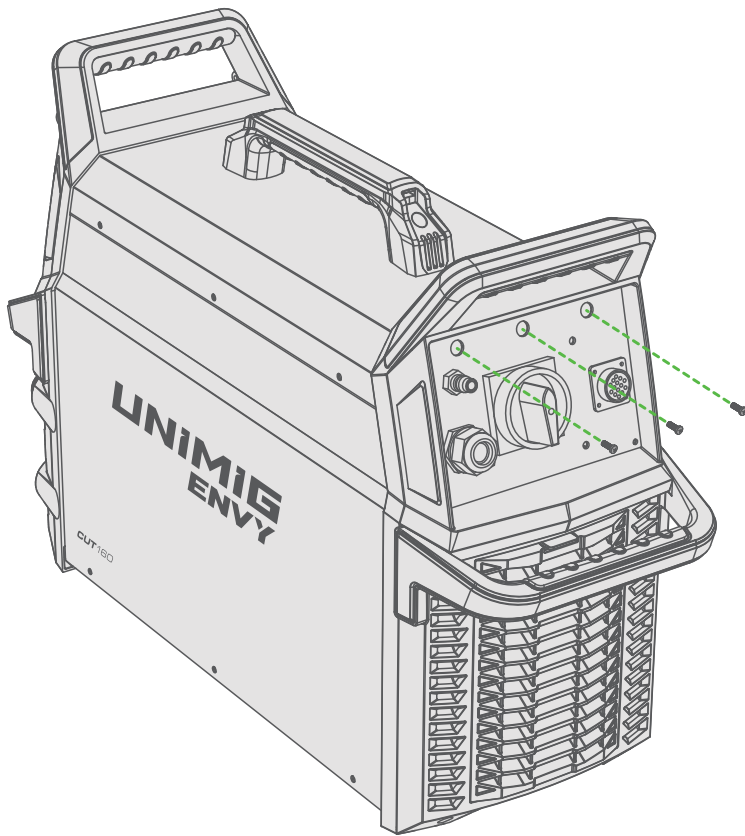

4. Remove the top cover on the machine.

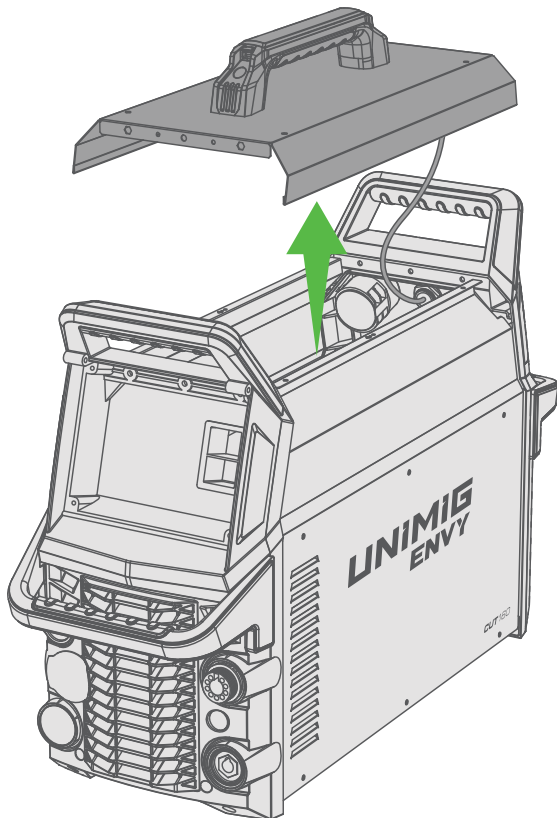

⚠ Be careful when lifting the top cover off, as it is connected to machine internals at the back.

Setting The DIP Switches

1. Locate the voltage divider DIP switches. They are situated towards the front of the machine.

i The figure below shows the default setting (20:1) with the number 1 switch on.

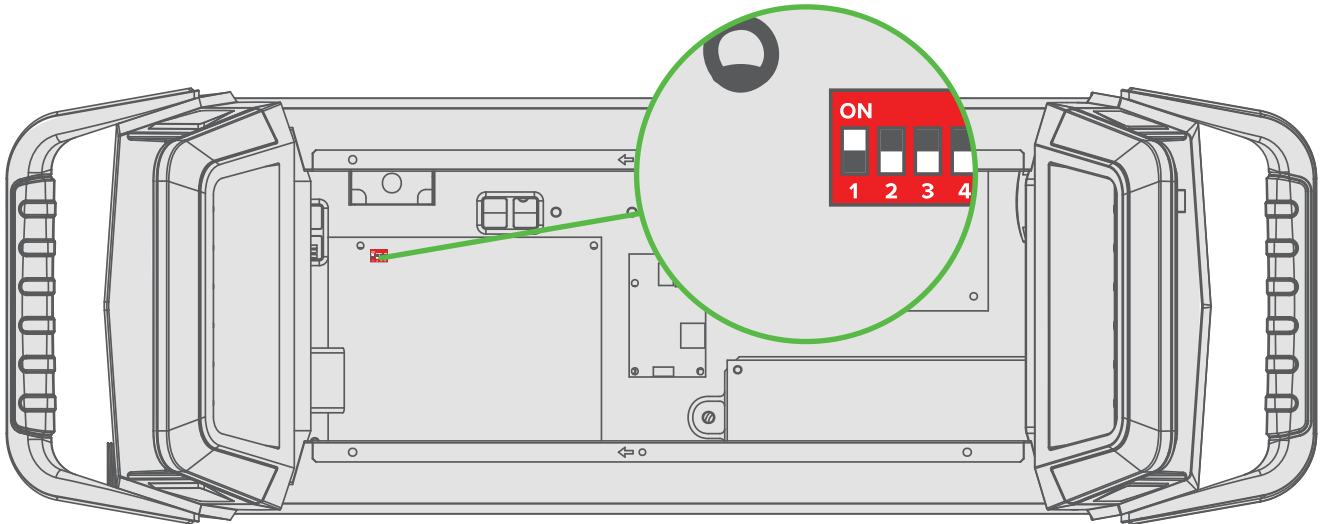

2. Set the DIP switches to one of the following settings and replace the machine cover.

50:1



40:1



30:1



20:1

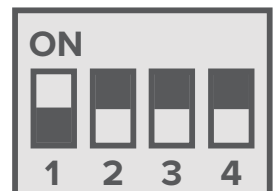

i For 1:1 voltage ratio, use pins 1 & 2 on the CNC Port.

6.7 Connecting the Plasma Cutter to a CNC Table (optional)

Connect the CNC plug into the CNC connection port on the plasma cutter.

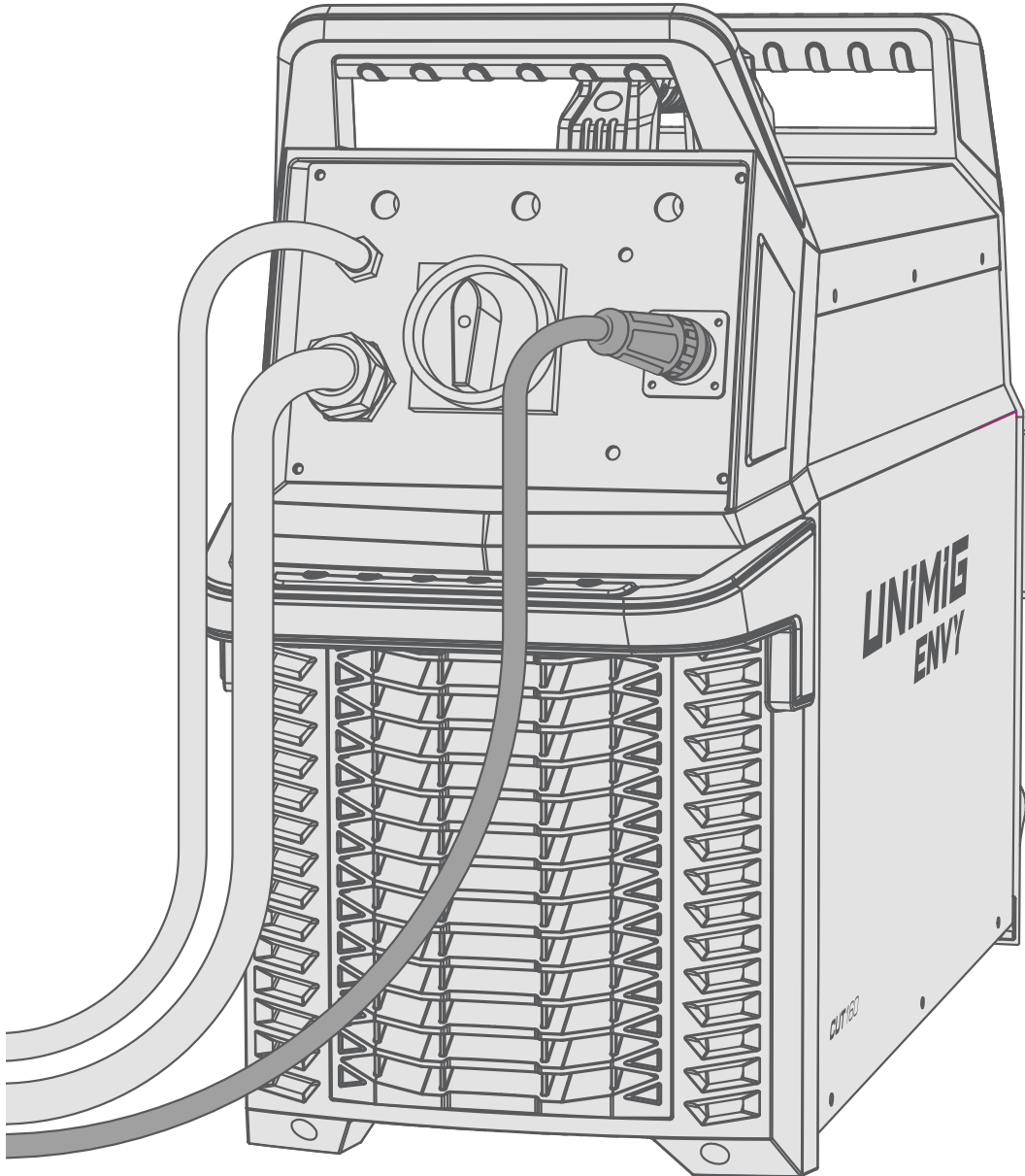

6.8 Assembling the CNC Plasma Torch

1. Screw the electrode into the torch head. Fasten securely.

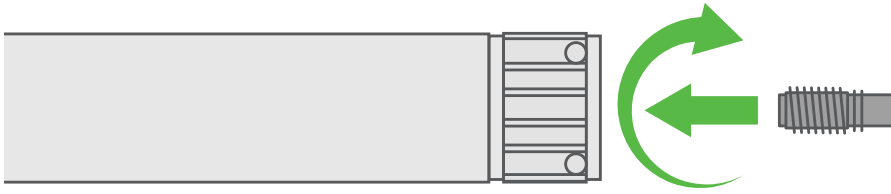

2. Place the swirl ring onto the electrode.



3. Place the cutting tip onto the swirl ring.



4. Screw the shield cap body onto the torch head. Fasten securely.

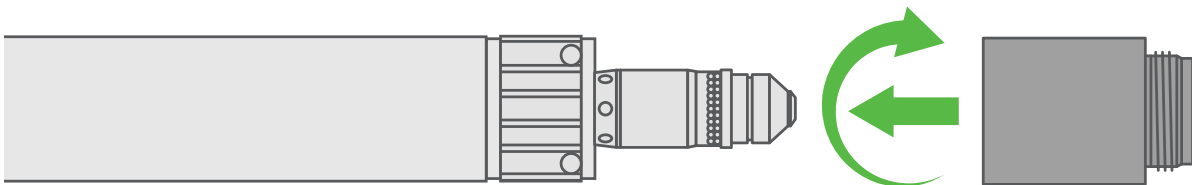

5. Screw the shield cap onto the shield cap body.

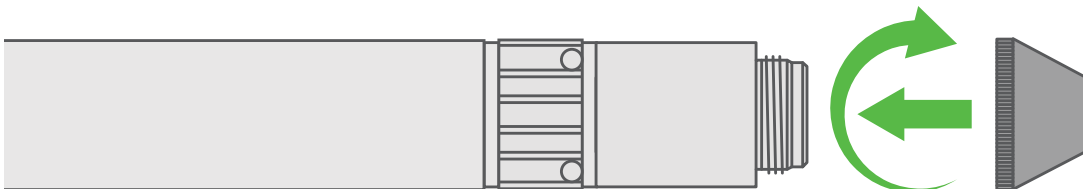

6.9 Connecting the CNC Torch (optional)

1. Assemble the CNC torch.
2. Connect the CNC torch into the Plasma central connection.

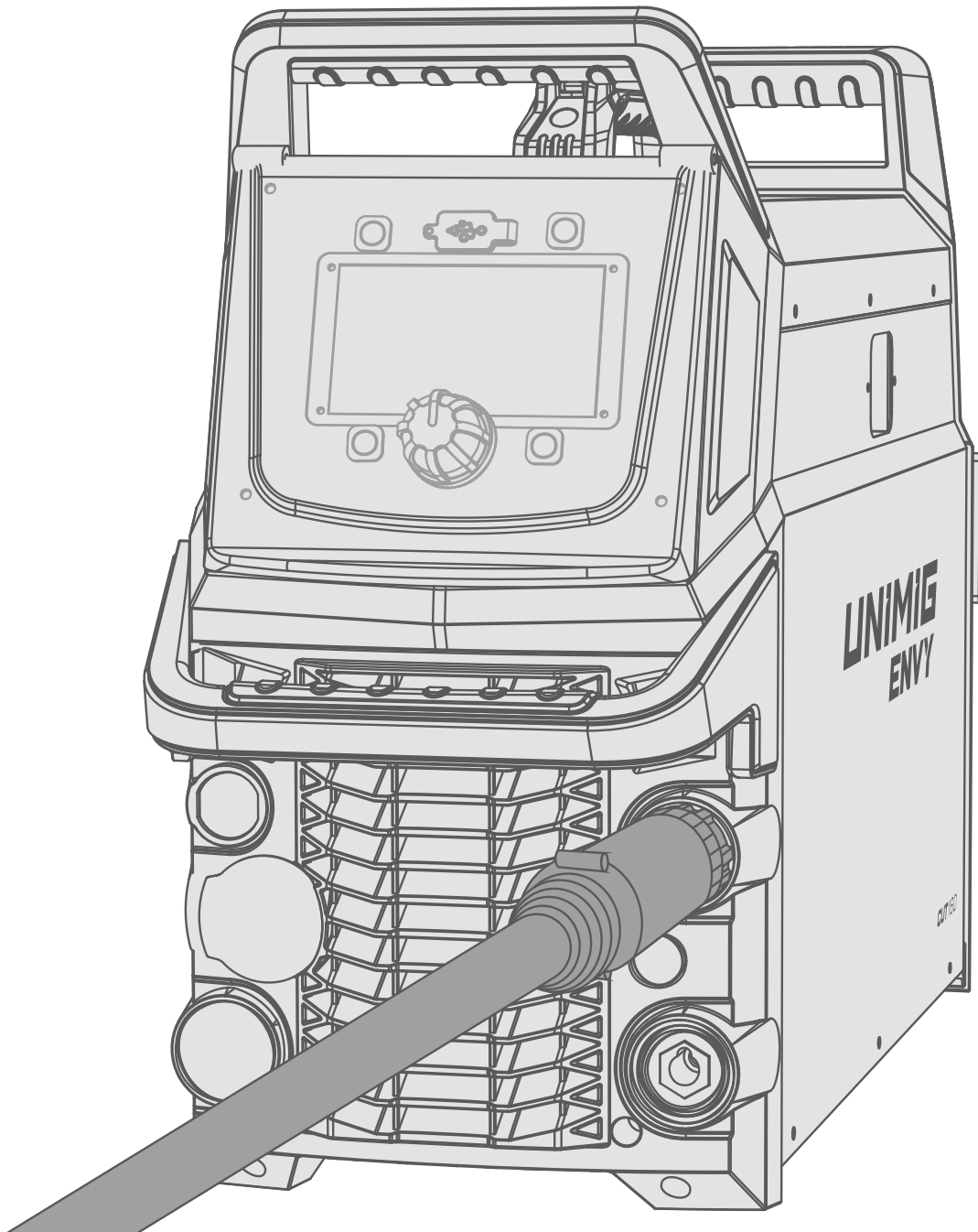

7. Operation

7.1 Preparing for Operation

Before using the equipment, ensure that all the necessary installation actions have been completed according to your equipment setup and instructions.

- i** Always check before use that the torch cable, air hose, earth cable/clamp and power cable are in serviceable condition. Ensure that the connectors are correctly fastened. Loose connectors can impair welding performance and damage connectors.

Connect the plug into the mains socket, then switch the machine ON.

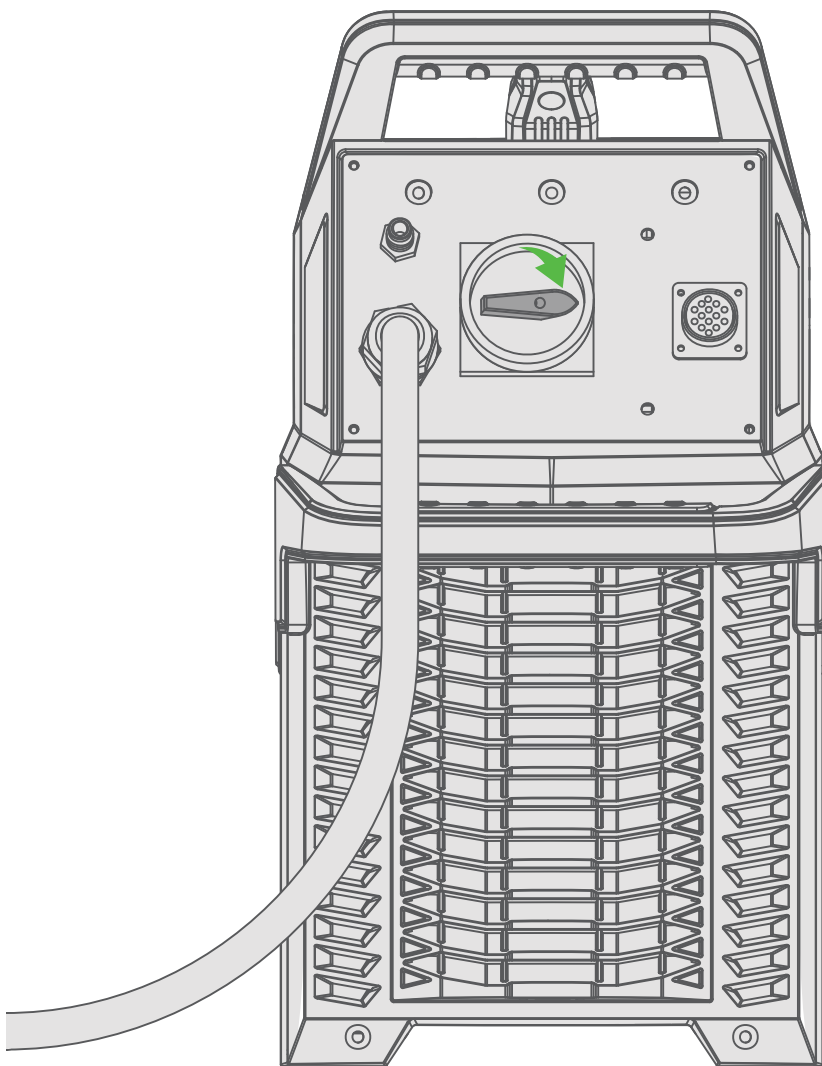

7.2 Control Panel Layout & Operation

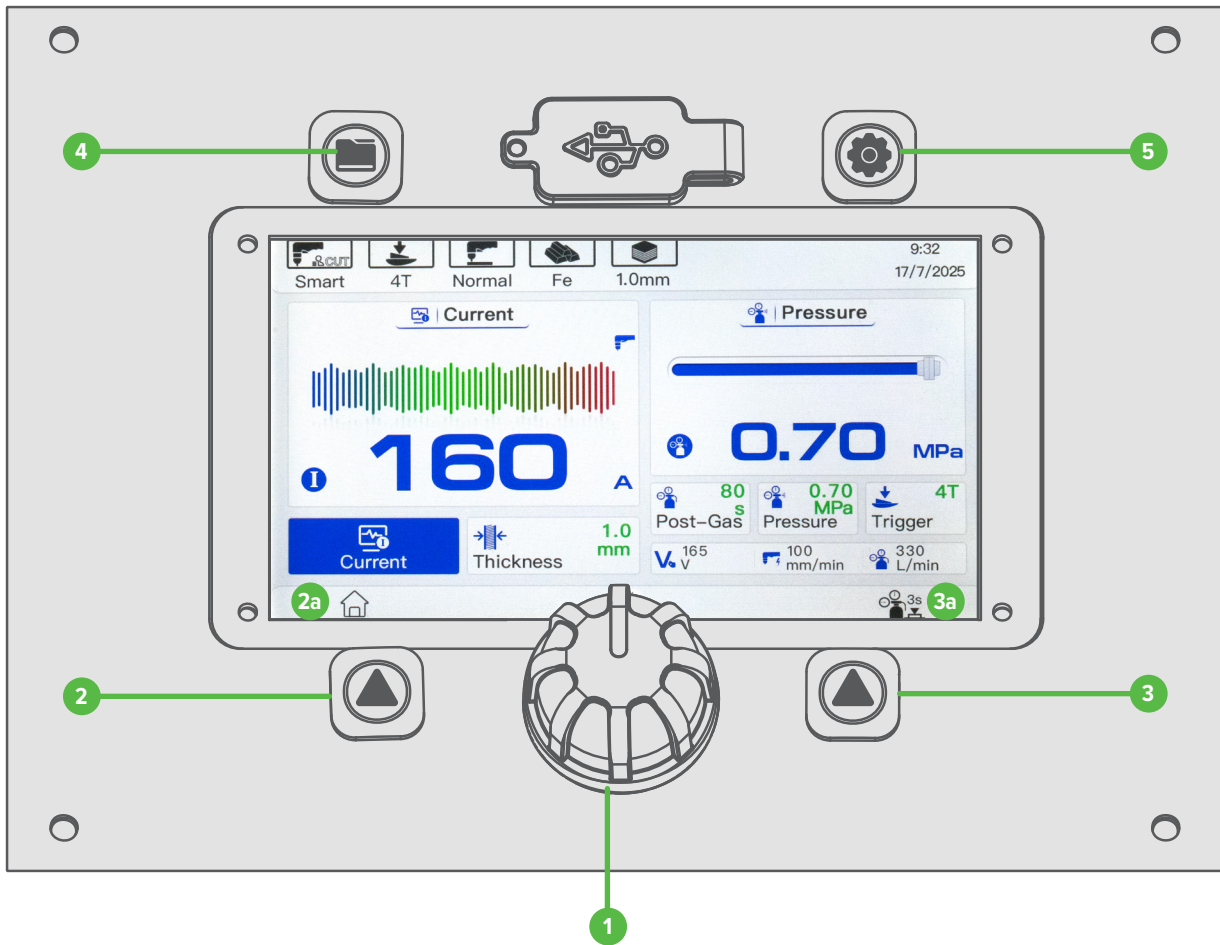

1. Control knob

- a. **Turn** this knob for digital screen navigation and cycling through menu options. If a menu option is active, turning this knob will adjust the item value.
- b. **Press** this knob to confirm actions between the weld screen and weld menu parameters. Pressing this knob also cycles through weld cycle parameters.

2. Left select button

Press the left select button to select the action in **2a**.

3. Right select button

Press the right select button to select the action in **3a**.

4. Job button

Press the Job button to open the Job Menu.

5. Setting button

Press the Settings button to open the Settings Menu.

7.3 Cut Mode

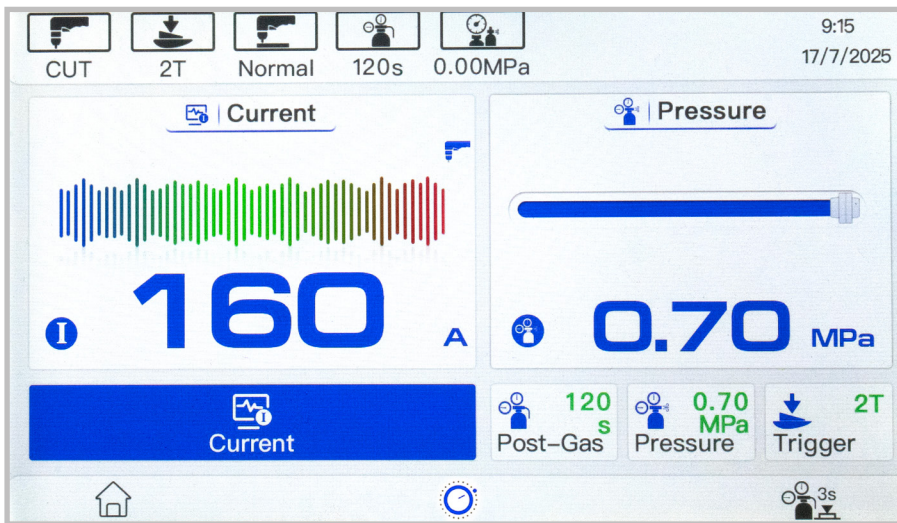

1. From the home screen, **press** the left control knob to select **Cut Mode**.
2. **Turn** the control knob to choose a cut mode and **press** to select it.
3. **Press** the control knob to cycle through Current, Post-Gas, Pressure and Trigger. **Turn** the control knob to adjust the parameter.
4. **Press** and hold the right select button to perform an Air Test.
5. **Press** the left select button to return to the home screen.

7.3.1 Cutting Parameters

Parameter	Value	Description
Current	20A - 120A (ENVY CUT 120) 20A - 160A (ENVY CUT 160)	Sets the maximum current level while plasma cutting.
Post-Gas	5s - 120s	Sets the duration of air released after the plasma arc stops.
Pressure	0.20MPa - 0.70MPa	Sets the air flow pressure while plasma cutting.
Trigger	2T / 4T	Switch between torch trigger modes: Torch Mode 2T Initiates cutting when the torch trigger is pressed and stops when released. Torch Mode 4T Press the torch trigger once to start cutting and release it. Press again to stop the cut. This mode is useful for longer cuts and reducing hand fatigue.

7.4 Smart-Set Cut Mode

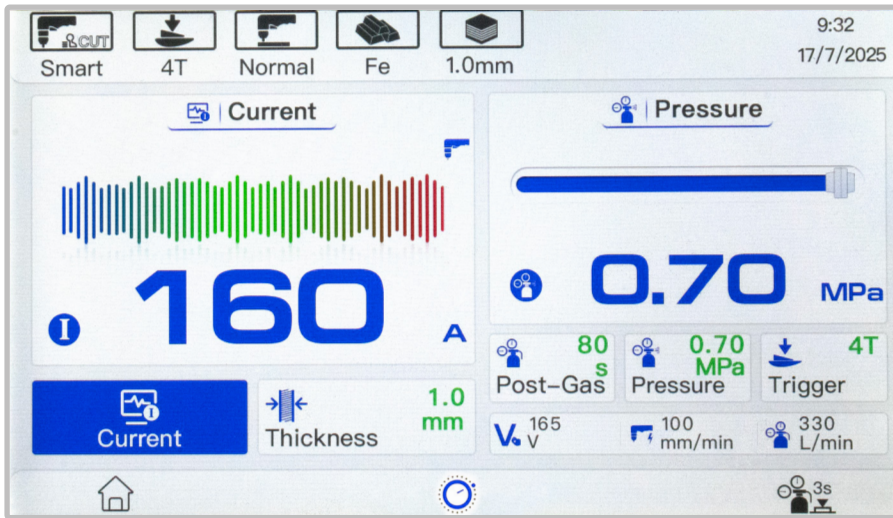

1. From the home screen, **press** the left control knob to select **Smart-Set Cut Mode**.
2. **Turn** the control knob to choose a cut mode and **press** to select it.
3. **Turn** the control knob to choose a material and **press** to select it.
4. **Turn** the control knob to choose a material thickness and **press** to select it.
5. **Press** the control knob to cycle through Current, Post-Gas, Pressure and Trigger. **Turn** the control knob to adjust the parameter.
6. **Press** and hold the right select button to perform an Air Test.
7. **Press** the left select button to return to the home screen.

7.4.1 Cutting Parameters

Parameter	Value	Description
Current	20A - 120A (ENVY CUT 120) 20A - 160A (ENVY CUT 160)	Sets the maximum current level while plasma cutting.
Thickness	1mm - 60mm (ENVY CUT 120) 1mm - 70mm (ENVY CUT 160)	Sets the workpiece thickness.
Post-Gas	5s - 120s	Sets the duration of air released after the plasma arc stops.
Pressure	0.20MPa - 0.70MPa	Sets the air flow pressure while plasma cutting.
Trigger	2T / 4T	Switch between torch trigger modes. Trigger Mode 2T Initiates cutting when the torch trigger is pressed and stops when released. Trigger Mode 4T Press the torch trigger once to start cutting and release it. Press again to stop the cut. This mode is useful for longer cuts and reducing hand fatigue.

i The settings available will depend on the parameters selected.

7.5 Job Menu

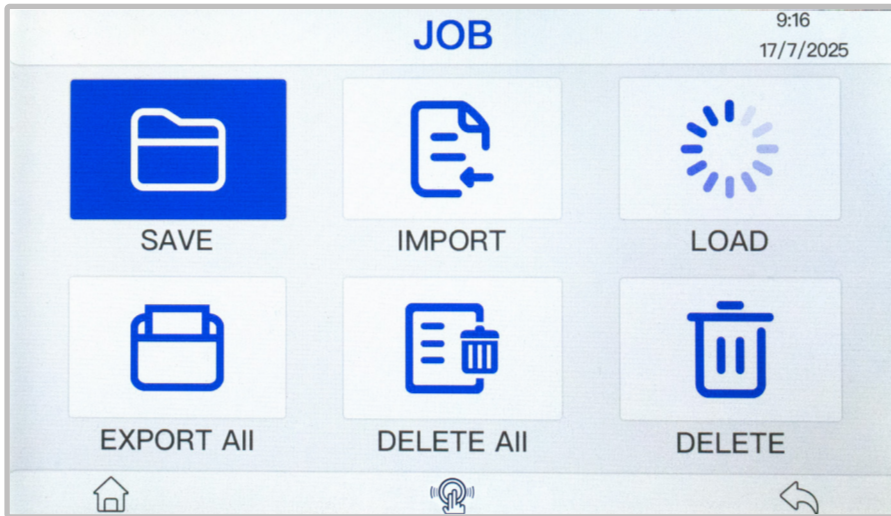

1. **Press** the Job button to open the Job Menu screen.
2. **Turn** the control knob to choose an option. **Press** to select it.

7.5.1 Saving a Job

1. On the weld screen and parameters you want to save, **press** the Job button. **Press** the control knob to select Save.
2. **Press** the control knob to select New Job.
3. Choose a name for the job. **Turn** the control knob to navigate the keyboard and **press** it to select each letter. **Press** Enter to save.

7.5.2 Overwriting a Job

1. In the Save Job screen, **turn** the control knob to hover over and **press** to select the job you want to overwrite.
2. **Turn** the control knob and **press** to select Overwrite to confirm. This will erase the previous job stored under that name.

7.5.3 Importing a Job

Info If you don't have a USB plugged into the machine, you will get a warning message in the top left corner 'No USB storage device detected, please connect the USB storage device and try again'.

1. **Press** the control knob to select Import to bring up the USB files.
2. **Press** and **turn** the control knob to select the job(s) you want to import.

7.5.4 Exporting a Job





Info If you don't have a USB plugged into the machine, you will get a warning message in the top left corner 'No USB storage device detected, please connect the USB storage device and try again'.

1. **Press** the control knob to select Export.
2. A popup 'Export complete' will appear if the export was successful.







7.5.5 Deleting a Job

There are two options to delete a job: Delete All or Delete.

To delete every saved job on the machine:

1.  **Turn** and  **press** the control knob to select Delete All. A confirmation message will appear.
2.  **Turn** and  **press** the control knob to select Delete to confirm.

To delete a single job on the machine:

1.  **Turn** and  **press** the control knob to select Delete.
2. In the Delete Job menu,  **turn** and  **press** the control knob to select the job you want to delete. A confirmation message will appear.
3.  **Turn** and  **press** the control knob to select Delete to confirm.

7.6 Settings Menu

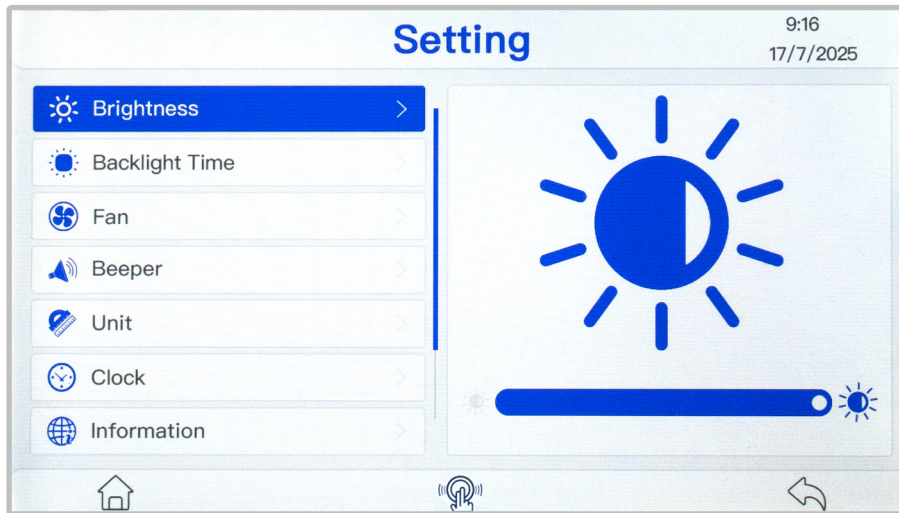

1. **Press** the Settings button to open the Settings Menu screen.
2. **Turn** the control knob and **press** to select the setting.
3. **Turn** and/or **press** the control knob to adjust the selected setting.
4. **Press** the right select button to exit out of the selected setting.

7.6.1 Welding Parameters

Setting	Value	Description
Brightness	1 - 18	Sets the brightness level of the screen.
Backlight Time	15min / 30min / 1h / Never	Sets the amount of time before standby mode activates.
Fan	Normal / Smart	Sets the type of fan operation.
Beeper	1 - 20	Sets the volume level of the beeper during machine operation.
Unit	Metric / Inch	Sets the unit of measurement.
Clock	Year / Month / Day / Hour / Minute	Sets the date and time displayed on the machine.
Information		Machine information, working time and up time.
Factory Reset	No / Yes	Factory reset the machine. Press the right control knob to enter the menu choice beyond the warning.
Program Update	Yes / No	Update the software version of the machine. Press the right control knob to enter the menu choice beyond the warning.

8. Maintenance

How often the machine is used and the working environment it is in should both be considered when planning the frequency of maintenance. In severe conditions, maintenance should occur more frequently.

Proper operation of the machine and regular preventive maintenance will help avoid equipment failure, increase the life-span of the machine and ensure problem-free welding.

⚠ Turn the machine off and unplug it from the mains before beginning any maintenance.

Before each use, check your air hose, earth clamp and cable, and power cable are in good condition. Check that all connections are properly fastened. Any loose connections can inhibit welding performance and cause damage.

- Check that all covers and components are intact.
- Check the consumables are installed properly and not worn.
- Check all electrical cables and connections every 6 months.
- Clean any oxidised connections and tighten them.
- Clean dirt and dust from the outside and inside of the unit with a vacuum cleaner and soft brush.

ⓘ Do not use any pressure-washing devices. Do not use compressed air, the pressure may pack the dirt even more tightly into components.







⚠ Only authorised electricians or service repair agents should carry out repairs and internal servicing.

For repairs, contact UNIMIG at unimig.com.au or contact your local dealer.

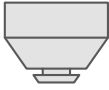
8.1 Maintaining the Consumables

How often you need to change the consumables on your torch will depend on a number of factors:

- The material thickness.
- The average length of the cut.
- The air quality through the plasma cutter. The presence of oil, moisture, or other contaminants will cause more consumable wear.
- Whether the metal is being pierced or the cut starts from the edge.
- A proper torch-to-work distance when gouging or cutting with unshielded consumables.
- A proper piercing height.
- Whether it's cutting in perforated mode or normal mode. Cutting in perforated mode causes more consumable wear.

Part	Check	Recommended Action
 <p>Shield Cap</p>	Check the centre hole is round and that there isn't any built up residue in the gap between the shield cap and the cutting tip.	<p>Replace the shield cap if the centre hole is no longer round.</p> <p>Remove the shield cap and clean any residue.</p>
 <p>Cutting Tip</p>	<p>Check the centre hole is round.</p>  <p>Good Worn</p>	Replace the cutting tip if the centre hole is no longer round.
 <p>Swirl Ring</p>	Check the surface inside the swirl ring for damage or wear, and check the gas holes for any blockages.	Replace the swirl ring if the surface is worn or damaged or if any of the gas holes are blocked.
 <p>Electrode</p>	<p>Check the surface for wear, and that the pit depth on the electrode's tip isn't deeper than 1.6mm.</p>  <p>Max. 1.6mm</p>	Replace the electrode if the surface is worn or the pit depth is greater than 1.6mm.
 <p>Torch O-ring</p>	Check the surface for damage and wear.	Replace the O-ring if it's worn or damaged.

9. Troubleshooting

i The issues and potential reasons outlined are not exhaustive but indicate common scenarios that might arise with regular use of the machine.

9.1 Machine Troubleshooting

Problem	Recommended Actions
The machine does not power up	<ul style="list-style-type: none"> • Check that the power cable is plugged in properly. • Check that the mains switch of the power source is at the ON position. • Check that the mains power distribution is on. • Check the mains fuse and/or the circuit breaker.
The machine stops working	<ul style="list-style-type: none"> • The torch may have overheated. Wait for it to cool down. • Check that none of the cables are loose. • The power source may have overheated. Wait for it to cool down and see that the cooling fans work properly and the air flow is unobstructed.

9.2 Plasma Troubleshooting

Problem	Recommended Actions
The arc doesn't ignite	<ul style="list-style-type: none"> • The air pressure may be incorrect, check and adjust the air pressure to 75psi (0.5MPa/5bar). • Check that the torch consumables are installed properly. • Check that the torch leads are correctly connected to the machine. • Check that the earth clamp is properly connected to a clean, dry area of the workpiece.
The temperature lamp is on, and the arc doesn't ignite	<ul style="list-style-type: none"> • The power source is overheated. Wait for it to cool down and see that the cooling fans work properly and the airflow is unobstructed.
The arc stops while cutting and won't restart	<ul style="list-style-type: none"> • The power source may have overheated. Wait for it to cool down and see that the cooling fans work properly and the airflow is unobstructed. • Check the torch consumables for wear and replace any that are worn.
The arc doesn't transfer to the workpiece	<ul style="list-style-type: none"> • Check that the earth clamp is properly connected to a clean, dry area of the workpiece and replace if damaged. • The pierce height distance may be too large. Move the torch closer to the workpiece and start the arc again.
The arc is hard to start	<ul style="list-style-type: none"> • Check the torch consumables for wear and replace any that are worn.
The arc sputters and hisses	<ul style="list-style-type: none"> • The air pressure may be incorrect, check and adjust the air pressure to 75psi (0.5MPa/5bar). • Check that the torch consumables are installed properly. • Check the air hose line for moisture. Replace or install additional air filtration to the power source (see "6.5 Installing Additional Air Filters" on page 23).
The arc blows out but re-ignites when the torch trigger is pressed again	<ul style="list-style-type: none"> • Check the torch consumables for wear and replace any that are worn. • The air pressure may be incorrect, check and adjust the air pressure to 75psi (0.5MPa/5bar).
Low cutting output	<ul style="list-style-type: none"> • The amperage may be incorrect, adjust the amperage.
No airflow	<ul style="list-style-type: none"> • Check that the air compressor is connected properly and that the air pressure is correct, adjust the air pressure to 75psi (0.5MPa/5bar).

Problem	Recommended Actions
<p>The torch does not cut completely through the workpiece</p>	<ul style="list-style-type: none"> • Check that gouging consumables aren't installed instead of cutting consumables. • The air pressure may be incorrect, check and adjust the air pressure to 75psi (0.5MPa/5bar). • Remove materials like paint, grease, oil, and dirt, including mill scale, from the base metal. • Check the torch consumables for wear and replace any that are worn. • Check that the earth clamp is properly connected to a clean, dry area of the workpiece and replace if damaged. • The amperage may be too low, increase the amperage. • The metal being cut is too thick for the maximum capacity of the machine. • The cut speed may be too fast. Reduce the cut speed.
<p>Dross forms on the bottom of the cut</p>	<ul style="list-style-type: none"> • The air pressure may be incorrect, check and adjust the air pressure to 75psi (0.5MPa/5bar). • Check the torch consumables for wear and replace any that are worn. • The cut speed may be incorrect. Adjust the cut speed. • The amperage may be too low, increase the amperage.
<p>The cut angle is not square</p>	<ul style="list-style-type: none"> • The torch is not square to the workpiece. • The air pressure may be incorrect, check and adjust the air pressure to 75psi (0.5MPa/5bar). • Check the torch consumables for wear and replace any that are worn. • The direction of travel may be incorrect. See "Cut Direction & Angle" on page 45 for the proper technique. • The torch height from the workpiece may be incorrect. • The cut speed may be incorrect. Adjust the cut speed.
<p>The cut is poor quality</p>	<ul style="list-style-type: none"> • The amperage may be too low, increase the amperage. • The cut speed may be incorrect. Adjust the cut speed. • Check the air hose line for moisture. Replace or install additional air filtration to the power source (see "6.5 Installing Additional Air Filters" on page 23). • The metal being cut is too thick for the maximum capacity of the machine. • Check that gouging consumables aren't installed instead of cutting consumables. • Check the torch consumables for wear and replace any that are worn. • The air pressure may be incorrect, check and adjust the air pressure to 75psi (0.5MPa/5bar). • Check the air hose line for moisture. Replace or install additional air filtration to the power source (see "6.5 Installing Additional Air Filters" on page 23). • Check that the machine is in the correct cutting mode (see "7.2 Control Panel Layout & Operation" on page 32).
<p>The consumable life is shorter than expected</p>	<ul style="list-style-type: none"> • The air pressure may be incorrect, check and adjust the air pressure to 75psi (0.5MPa/5bar). • The amperage, travel speed, and other variables may be incorrect for the material being cut. • The pierce height distance may be too large. Move the torch closer to the workpiece. • Check the air hose line for moisture. Replace or install additional air filtration to the power source (see "6.5 Installing Additional Air Filters" on page 23).

9.3 Error Codes

Error Code	Name	Description	Potential Action
E01	Over Temperature!	The plasma cutter is overheating.	Check the fan is operating, wait for the welder to cool down. If the problem persists, contact UNIMIG customer service.
E02	Over Temperature!	The plasma cutter is overheating.	Check the fan is operating, wait for the welder to cool down. If the problem persists, contact UNIMIG customer service.
E10	Phase loss Error	The input power cable is out of phase.	Check the input cable is securely connected, and check the voltage coming from the outlet and try a different outlet. If the problem persists, contact UNIMIG customer service.
E12	Low Air Pressure Error	The input air pressure is too low.	Check the air compressor is securely connected, and check the air pressure is set correctly. If the problem persists, contact UNIMIG customer service.
E13	Low Input Power	The machine isn't getting enough voltage to operate.	Remove extension leads or try a different outlet. If the problem persists, contact UNIMIG customer service.
E14	High Input Power	The machine is receiving too much voltage, which can cause damage to the internal components.	Try a different outlet. If the problem persists, contact UNIMIG customer service.
E30	CUT Torch Disconnected Error	The cutting torch is not connected.	Check the torch is securely connected. If the problem persists, contact UNIMIG customer service.
E34	Bluetooth Module Error	The Bluetooth module failed to start.	Check the Bluetooth module cable is securely connected. If the problem persists, contact UNIMIG customer service.
E41	Communication DATA Error!	There is a problem with the communication data between the display PCB and the control PCB.	If the problem occurs, contact UNIMIG customer service.
E42	Password Error!	Main board password is wrong.	The screen calibration may have failed, try again. If the problem persists, contact UNIMIG customer service.
E46	Communication DATA Error2!	There is a problem with the communication data between the display PCB and the torch check PCB.	If the problem occurs, contact UNIMIG customer service.
E50	Read Flash Error!	Incorrect data has been read from the flash drive/USB, resulting in the loss of key parameters required for normal operation.	If the problem occurs, contact UNIMIG customer service.

 After attempting the possible solutions listed in the chart above please contact UNIMIG Support Services if you are still experiencing issues with your machine.

10. Plasma Cutting Guide

What is Plasma Cutting?

Plasma is a super-heated column of gas. It's formed when compressed air or compressed gases (like nitrogen or argon) make contact with the electrode (which is inside the torch) and ionise to create plasma.

Plasma cutting (plasma arc cutting), therefore, is a melting process that uses plasma and an outside power source to create an electric arc between the electrode and the metal being cut to melt and eject it from the cut.

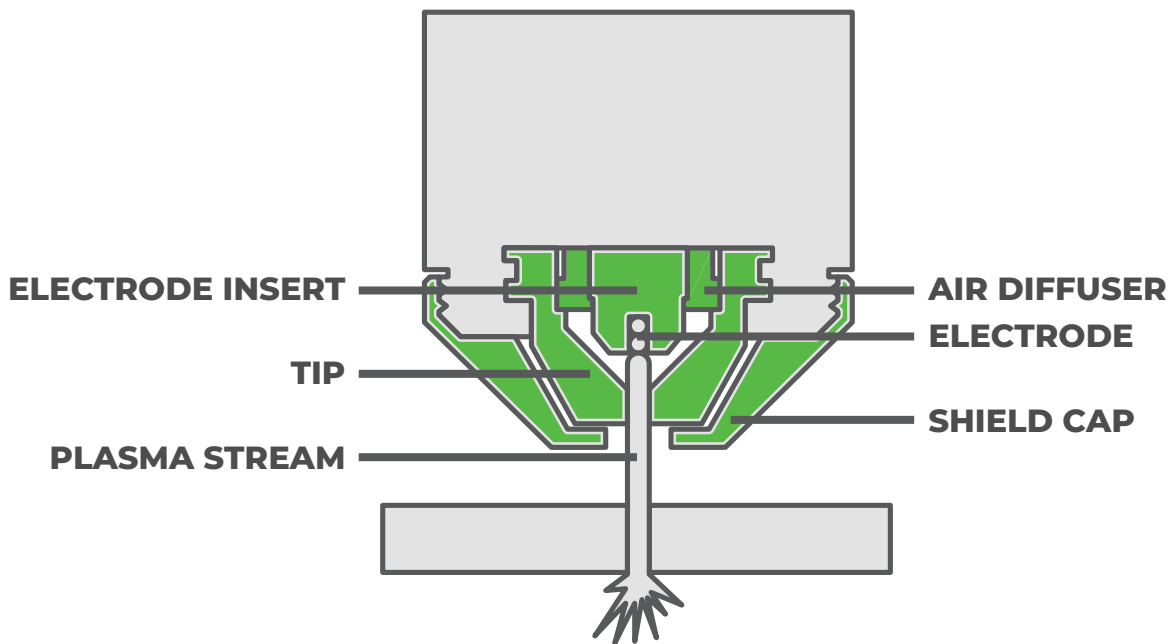

How Plasma Cutting Works

Plasma cutting requires a compressed air supply and a constant voltage, direct current power source to operate. The plasma arc is created by electrically heating compressed air to a very high temperature, which ionises its atoms and makes them conductive.

When air from the plasma torch is forced through the swirl ring, a fixed gap is established between the electrode and the tip. The air becomes ionised by the electrical arc from the electrode, transforming into plasma, which flows from the torch to the workpiece.

As the electricity from the torch travels through the plasma, it generates enough heat to melt the metal. The high-velocity plasma and compressed gas then blow the molten metal away.

What Materials Can Plasma Cut?

Plasma can cut through anything electrically conductive; steel, stainless steel and aluminium are all fair game. In comparison, oxy-cutting will only work on metals that contain iron, as it works through chemical reactions, such as oxidisation instead.

An arc is formed between the tungsten electrode and the workpiece. Tungsten has a melting point of 3,422°C, so it can withstand the heat of a welding arc. That's why it is a 'non-consumable' electrode. It doesn't melt and enter the weld pool. To add metal, an additional filler rod can be fed into the weld puddle by hand to form a proper weld.

TIG welding is the only welding process that requires the use of both hands to create the weld, so it is a completely manual process that has a steeper learning curve than MIG or MMA.

Clean Cut vs Severance Cut

You can get two types of cut with your plasma cutter: a clean cut or a severance.

Clean cut: a smooth, clean cut on the metal.

Severance: a cut all the way through, but it won't be smooth, and it'll need to be cleaned up.

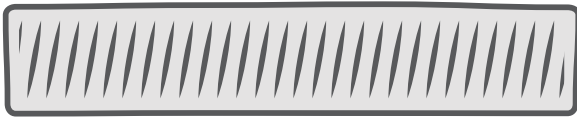

CLEAN CUT

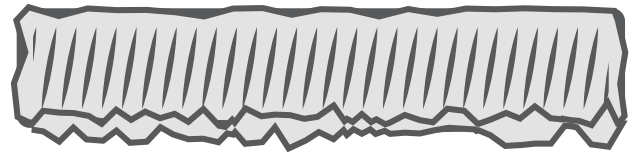

SEVERANCE

Every plasma machine has a maximum clean cut thickness and a maximum severance. These indicate how thick the metal can be to achieve a good-quality cut and how thick the metal can be if all you need is to get through it. The severance thickness will always be more than the clean cut thickness.

The cut thicknesses will vary depending on the type of metal. Aluminium and stainless steel have a higher viscosity (which is a fluid's resistance to flow) than mild steel, so their max cutting thickness is usually less than mild steel's max thickness because of their viscosity.

Plasma Cutting Basics

Amperage

The thicker the material, the more amperage required.

On thick material, set the machine to its maximum output and vary your travel speed. On thinner material, turn down the amperage and change to a lower-amperage tip to maintain a narrow kerf. The kerf is the width of the cut material that is removed during cutting.

Make sure the torch's consumables can handle the amperage it's outputting. If the machine is set to 80A and the consumables can only handle 60A max, you'll burn through them.

Travel Speed

The travel speed will depend on the thickness of the material being cut. When travelling at the correct speed, the sparks should come out the bottom of the plate, lagging behind the torch at a slight angle (roughly 15° - 30° from vertical).

If you're cutting too fast, the sparks will spray at a very steep angle in the opposite direction than you're cutting. Some sparks might even fly out from the top. If they're flying out of the top, it means the plasma arc isn't cutting all the way through, and the sparks are bouncing off the part that is still joined together.

If they come out straight down and get stuck in grooves, you're cutting too slow. Cutting too slowly results in a wider kerf (the material lost due to the cutting process) and dross (excess metal from the cut that hardens on the bottom of the piece and needs to be cleaned off). Cutting too slow also makes the cut much harsher; it won't be as smooth as it could be.

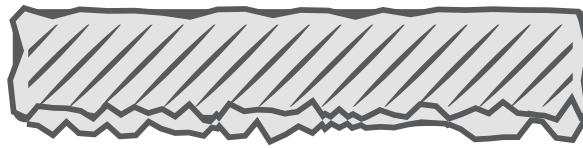

✘ TOO FAST

Tip Size & Condition

The tip orifice focuses the plasma stream to the workpiece, which is why it's essential to use the correct size tip for the amperage being used.

A tip suited for lower amperages has a smaller orifice which maintains a narrow plasma stream for use on thin material. Using a 25A tip at a 60A setting will blow out and distort the tip orifice and require replacement. On the other hand, using an 80A tip on the lower settings will not allow you to focus the plasma stream as well and results in a wide kerf.

The condition of the tip orifice is critical to the quality of the cut result. A worn or damaged tip orifice will produce a distorted plasma stream, resulting in poor cut quality.

Cut Direction & Angle

It is easier to pull (drag) the torch towards you than push it. The plasma stream swirls as it exits the tip, biting one side and finishing off on the other, leaving a bevelled edge and a straight edge.

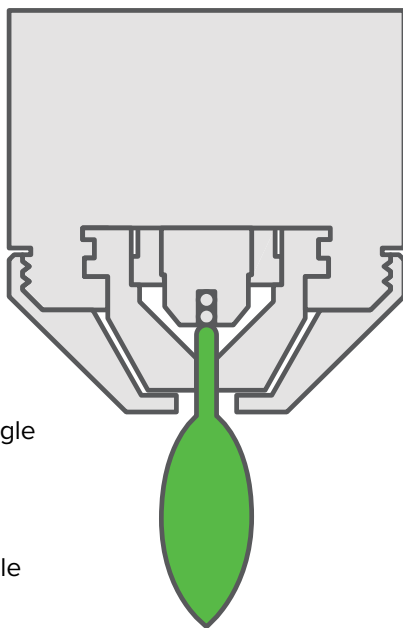

Problem

- Negative cut angle
- Square cut
- Positive cut angle

Cause

- The torch is too low.
- The torch is too high.

Solution

- Raise the torch; or if you are using a torch height control, increase the arc voltage.
- Lower the torch; or if you are using a torch height control, decrease the arc voltage.

- A positive cut angle occurs when more material is removed from the top of the cut than from the bottom.
- A negative cut angle occurs when more material is removed from the bottom of the cut.

The bevel-cut effect is more noticeable on thicker material and needs to be taken into consideration before starting your cut, as you want the straight side of the cut to be on the finished piece you keep.

i The squarest cut angle will be on the right side in relation to the forward motion of the torch. The left side will always have some degree of bevel.

Dross

Some amount of dross is inevitable when plasma cutting, but you can minimise it by adjusting your settings to your specific application.

Excess dross appears on the top edge of both pieces of the plate when the torch height is too low. To reduce this, adjust the torch until the dross is minimised.

Low-Speed Dross

Low-speed dross forms when the cutting speed is too slow. It appears as a heavy, bubbly deposit at the bottom of the cut and can be easily removed. To reduce low-speed dross, increase the cutting speed.

High-Speed Dross

High-speed dross occurs when the cutting speed is too fast. It forms as a thin, linear bead of solid metal attached very close to the cut. This type of dross is more firmly attached to the bottom of the cut and is difficult to remove. To reduce high-speed dross, decrease the cutting speed and reduce the torch height.

Torch Height & Position

The distance and position of the plasma torch cutting tip from the workpiece affect the quality of the cut and the extent of the bevel. The easiest way to reduce the bevel is to cut at the proper speed and height for the material and amperage being cut.

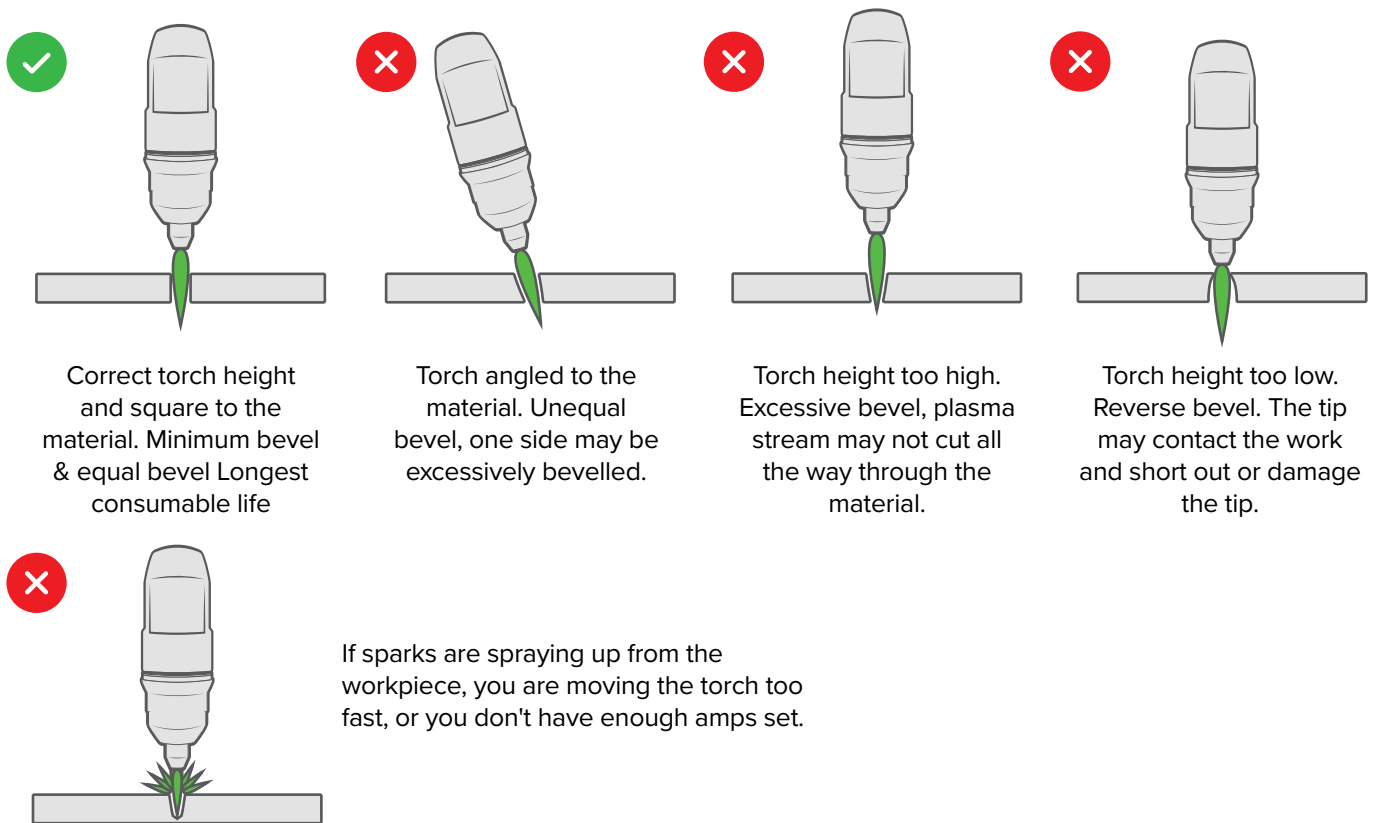

Add a piece of sheet metal to push the torch up against for extra accuracy on your cuts to keep your lines straight. You can also purchase circle cutting kits and cutting buggies for circles and curved lines.

Electrode Condition

A fixed gap is established between the electrode and the inside of the cutting tip. Electrons arc across the gap, ionising and superheating the air to create the plasma stream.

The electrode contains an insert at the end made of a highly conductive material called hafnium. This insert erodes with use and develops a pit at the end of the electrode. When the pit becomes too big, the quality of the cut becomes poor, and the electrode will need to be replaced.

Cutting From the Edge

To get the most out of your consumables, it's recommended to always start your cut from the edge of the workpiece. To do this:

1. Hold the torch tip vertically (90°) to the edge of the workpiece.

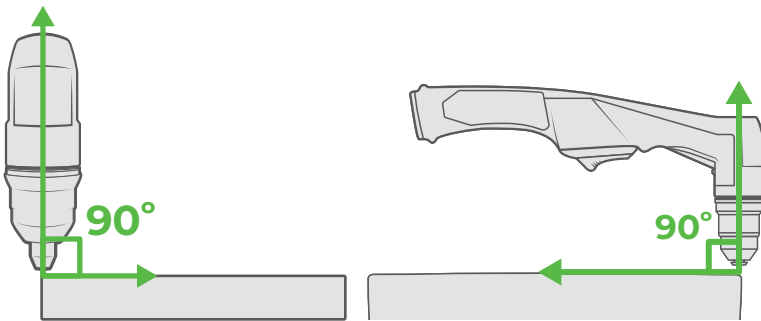

2. Start the arc and pause at the edge until the arc has cut completely through the workpiece.

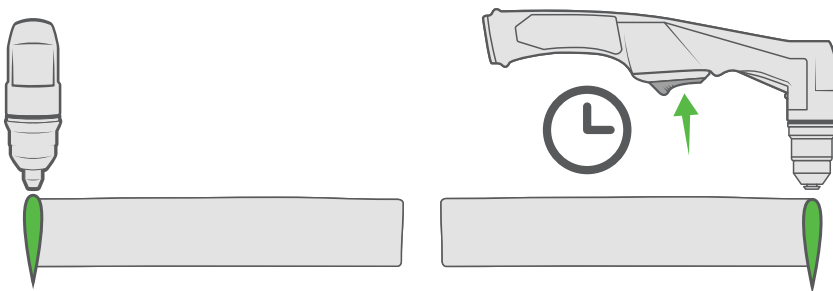

3. Drag the torch lightly across the workpiece and maintain a steady, even pace.

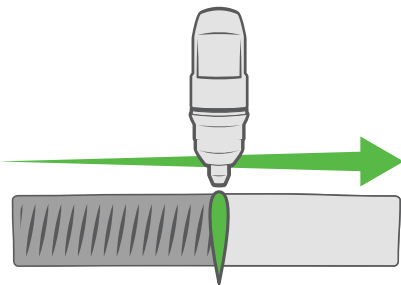

Piercing the Workpiece

It's not always possible to start a cut from the edge of the workpiece, you may need to start in the middle of the plate. To pierce the workpiece:

1. Hold the torch at approximately 30° angle to the workpiece with the torch tip roughly 1.5mm from the workpiece before starting the arc.

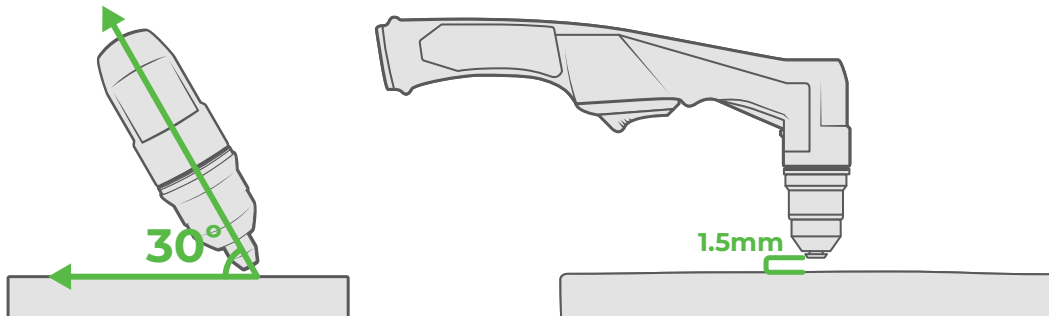

2. Start the cut while still at an angle to the workpiece and then slowly rotate the torch to a vertical (90°) position.

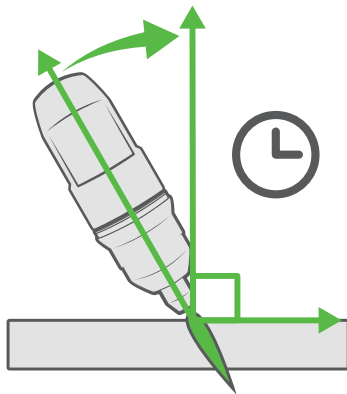

3. Hold the torch in place while continuing to press the trigger. When sparks exit below the workpiece, the arc has pierced the metal.

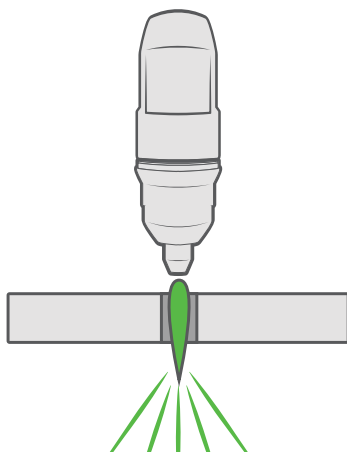

4. Once the metal has been pierced, drag the torch lightly along the workpiece and maintain a steady, even pace.

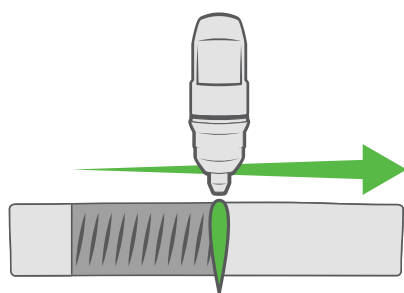

Gouging the Workpiece

Gouging is used when you want to remove metal from a piece without actually cutting through it. To do this:

1. Hold the torch at a 40° angle with the tip about 5mm - 10mm from the workpiece. Press the trigger to start the arc.

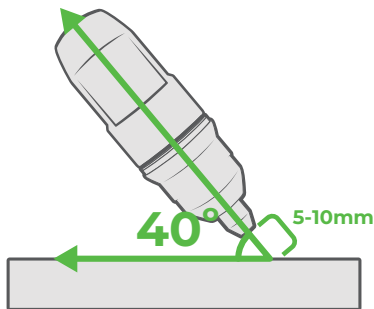

2. Pull the torch back and stretch the arc to roughly 30mm. Push the plasma arc in the direction of the gouge you want to create. Increase the standoff to create a shallower and wider gouge.

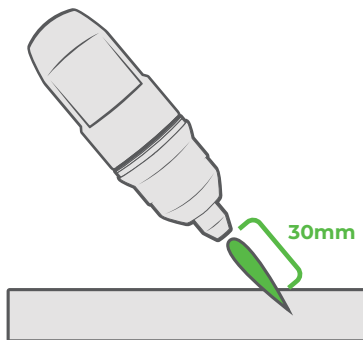

i Changing the torch's angle will change the dimensions of the gouge.

Air Pressure & Volume

The volume capacity of your compressor is important. If you have a small compressor with precisely the same L/min rating as the plasma, then the compressor will run continuously when you are plasma cutting. A compressor with a L/min rating slightly higher than the plasma would be more than adequate.

If you are doing a lot of cutting, cutting thick plate (same air consumption but slower cut speeds, which means a longer cut time), then choose a compressor at 1.5x – 2x the plasma cutter's requirement.

The air pressure regulator, in general, can be found on the back of the machine above the air filter. The regulator will have a hose that runs in on one side and out on the other, with a twistable valve on top. This valve is how you change the machine's air pressure, which you can see on the pressure gauge. A good starting pressure regardless of the machine is 75psi.

The amperage and air pressure work together, so if the amperage is all the way up, you'll want to increase the air pressure as well. You don't want one overpowering the other, as it'll give you a poor-quality cut.

Air Quality & Filtration

Good air quality is essential to the quality of the cut and the torch consumable's life span.

Compressors take in air at atmospheric pressure, increase the pressure, and store it in a tank. The humidity in the air is condensed in the tank, and the airlines produce water, more so in humid environments.

Moisture that forms in the airlines tends to condense into larger drops when the air pressure decreases as it enters the plasma torch. When these droplets enter the high temperatures (as much as 11,000°C) in the torch, they immediately break down into oxygen and hydrogen, which alters the regular chemical content of the air in the torch.

These elements will then dramatically change the plasma arc, which causes the torch consumable parts to wear very quickly, and alters the shape of the tip opening, dramatically affecting the cut quality in terms of edge squareness, dross formation, and edge smoothness.

Minimising moisture in the air supply is absolutely critical to quality plasma cuts and the longevity of consumable parts. Be sure to drain the receiver (tank) on the air compressor at least daily.

Most air plasma systems have an onboard particulate filter and/or a coalescing filter with an auto drain that removes some moisture from the air supply. The onboard air filter is adequate for home workshops and light industrial users.

However, most situations will require additional filtration to prevent moisture from affecting the quality of the plasma cutter. In most cases, it is recommended to install a submicronic particulate filter designed to trap water through absorption.

This style of filter should be installed as close as possible to the plasma cutter's air intake. It has a replaceable filter cartridge that absorbs water and must be changed after it's near saturation.

11. Plasma Cutting Processes & Features Glossary

A

Air Test - Test the air pressure and airflow from the compressor through to the torch.

G

Gouging - Remove material from a workpiece to create grooves, prepare weld joints, or remove welds or defects.

N

Normal Cutting - The plasma arc will cut through solid metal plate and will extinguish when it stops detecting metal.

P

Perforated Cutting - The plasma arc will cut through metal with gaps, like grating or mesh. The arc will remain constant while passing over areas that are not metal.

Post-Gas - The duration of air released after the plasma arc stops.

Pressure - The air flow pressure while plasma cutting.

S

Smart Cut - The Smart-Set Cut mode is a set of synergic programs that guide the user through the selection of required parameters in an easily understandable way for the optimal settings on every job.

T

Torch Mode 2T - Initiates the arc when the torch trigger is pressed and stops when released.

Torch Mode 4T - Press the torch trigger once to start the arc and release it. Press again to stop the arc. This mode is useful for longer cuts and reducing hand fatigue.

12. Plasma Torch & Consumables

12.1 SC160 Plasma Torch

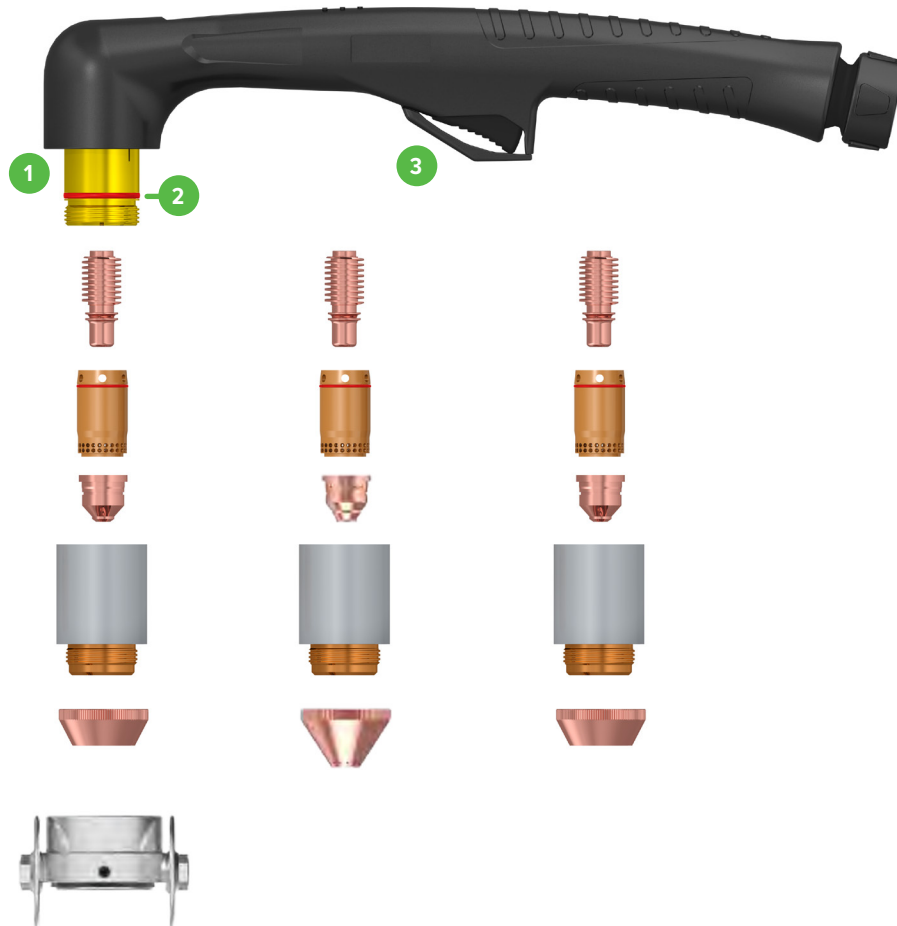

Length	6m
SKU	U43010

1	U11132	PLASMA TORCH HEAD SUIT SC160
2	U11133	O RING SUIT SC160 QTY 1
3	U11134	PLASMA TORCH HANDLE SUIT SC160

COOLING METHOD	Air-Cooled
DUTY CYCLE	80% @ 160A
GAS PRESSURE	5.0-6.0 Bar / 75-90 psi
GAS FLOW	420L/min
STANDARD	EN60974-7

12.2 SC160 Plasma Torch Consumables

12.2.1 Gouging

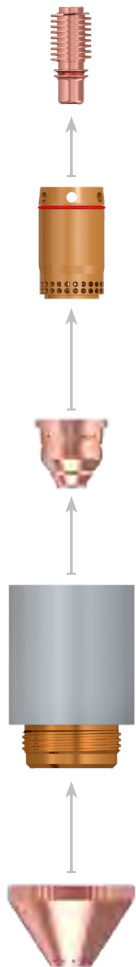

Electrode

U43009P	ELECTRODE SUIT SC160 QTY 5
----------------	----------------------------

Swirl Ring

U43008	SWIRL RING SUIT SC160 QTY 1
---------------	-----------------------------

Gouging Tips

U11215	GOUGING TIPS SUIT SC160 105-125A QTY 5
U11216	GOUGING TIPS SUIT SC160 160A QTY 5

Shield Cap Body

U11139	SHIELD CAP BODY SUIT SC160 45-85A QTY 1
U43006	SHIELD CAP BODY SUIT SC160 105-160A QTY 1

Shield Cap

U11217	SHIELD CAP GOUGING SUIT SC160 QTY 1
---------------	-------------------------------------

12.2.2 Cutting

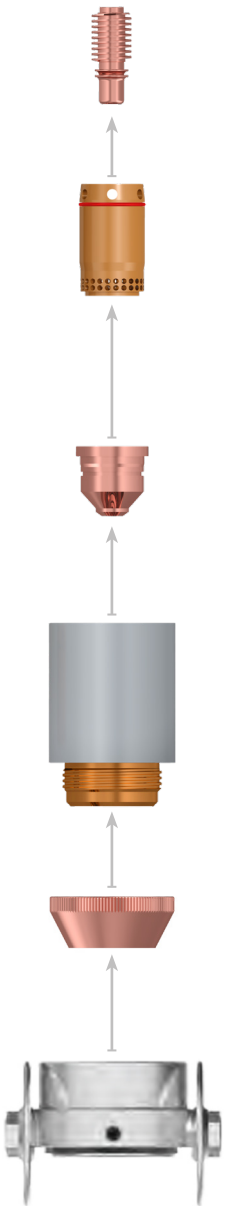

Electrode

U43009P	ELECTRODE SUIT SC160 QTY 5
----------------	----------------------------

Swirl Ring

U11253	SWIRL RING SUIT SC160 30-45A QTY 1
U43008	SWIRL RING SUIT SC160 QTY 1

Cutting Tips

U11140	CUTTING TIPS SUIT SC160 30-45A QTY 5
U11135	CUTTING TIPS SUIT SC160 45A QTY 5
U11136	CUTTING TIPS SUIT SC160 65A QTY 5
U11137	CUTTING TIPS SUIT SC160 85A QTY 5
U11138	CUTTING TIPS SUIT SC160 105-125A QTY 5
U43007P	CUTTING TIPS SUIT SC160 160A QTY 5

Shield Cap Body

U11139	SHIELD CAP BODY SUIT SC160 45-85A QTY 1
U43006	SHIELD CAP BODY SUIT SC160 105-160A QTY 1

Shield Cap

U11141	SHIELD CAP SUIT SC160 30-45A QTY 1
U11248	SHIELD CAP SUIT SC160 45-85A QTY 1
U43005	SHIELD CAP SUIT SC160 105-160A QTY 1

Cutting Guide

U11254	CUTTING GUIDE SUIT SC160 QTY 1
---------------	--------------------------------

13. Recommended Accessories



**SC160 CNC Plasma
Torch**

U43011 (6m)
U43012 (12m)

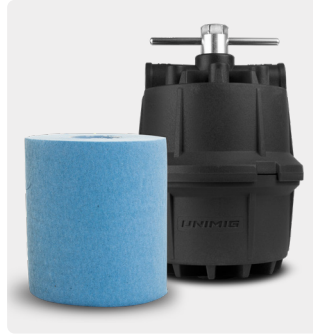

**Plasma Cutter Air
Filter**

U11235

UNIMIG



unimig.com

f @ UNIMIG