

3 YEAR
PRODUCT
WARRANTY



Unimig® RAZOR 200 PULSE

11003K | Operating Manual





CONTENTS

GENERAL INFORMATION

SAFETY.....	4
TECHNICAL DATA.....	8
MACHINE LAYOUT.....	9
WHAT'S IN THE BOX.....	11

DIGITAL SCREEN OPERATION

DIGITAL SCREEN - BASIC OPERATION.....	12
DIGITAL SCREEN - MACHINE SETTINGS MENU.....	13
DIGITAL SCREEN - MIG.....	14
DIGITAL SCREEN - TIG.....	16
DIGITAL SCREEN - STICK.....	18
DIGITAL SCREEN - JOB MEMORY.....	19

MIG SETUP

SETUP FOR MIG (GASLESS).....	20
SETUP FOR MIG (GAS-SHIELDED).....	26
MIG WELDING GUIDE.....	33
MIG DRIVE ROLLERS.....	38
CHANGING THE MIG TORCH LINER.....	39
CHANGING THE MIG TORCH LINER (ALUMINIUM).....	41

STICK SETUP

SETUP FOR MMA (STICK) WELDING.....	45
MMA (STICK) WELDING GUIDE.....	48

TIG SETUP

SETUP FOR TIG.....	50
DC TIG WELDING GUIDE.....	53

SPARES & TROUBLESHOOTING

TORCH BREAKDOWN & SPARES.....	58
MACHINE PARTS BREAKDOWN.....	60
FAQ & TROUBLESHOOTING.....	61

SAFETY

Welding and cutting equipment can be dangerous to both the operator and people in or near the surrounding working area if the equipment is not correctly operated. Equipment must only be used under the strict and comprehensive observance of all relevant safety regulations.

Read and understand this instruction manual carefully before the installation and operation of this equipment.

Machine Operating Safety

- Do not switch the function modes while the machine is operating. Switching of the function modes during welding can damage the machine. Damage caused in this manner will not be covered under warranty.
- Disconnect the electrode-holder cable from the machine before switching on the machine, to avoid arcing should the electrode be in contact with the workpiece.
- Operators should be trained and or qualified.



Electric shock: It can kill. Touching live electrical parts can cause fatal shocks or severe burns. The electrode and work circuit is electrically live whenever the output is on. The input power circuit and internal machine circuits are also live when power is on. In MIG/MAG welding, the wire, drive rollers, wire feed housing, and all metal parts touching the welding wire are electrically live. Incorrectly installed or improperly grounded equipment is dangerous.

- Connect the primary input cable, according to Australian and New Zealand standards and regulations.
- Avoid all contact with live electrical parts of the welding/cutting circuit, electrodes and wires with bare hands.
- The operator must wear dry welding gloves while he/she performs the welding/cutting task.
- The operator should keep the workpiece insulated from himself/herself.
- Keep cords dry, free of oil and grease, and protected from hot metal and sparks.
- Frequently inspect input power cable for wear and tear, replace the cable immediately if damaged, bare wiring is dangerous and can kill.
- Do not use damaged, undersized, or badly joined cables.
- Do not weld in the rain.
- Do not drape cables over your body.
- We recommend (RCD) safety switch is used with this equipment to detect any leakage of current to earth.



Fumes and gases are dangerous. Smoke and gas generated while welding or cutting can be harmful to people's health. Welding produces fumes and gases. Breathing these fumes and gases can be hazardous to your health.

- Do not breathe the smoke and gas generated while welding or cutting, keep your head out of the fumes.
- Keep the working area well ventilated, use fume extraction or ventilation to remove welding/cutting fumes and gases.
- In confined or heavy fume environments always wear an approved air-supplied respirator.
- Welding/cutting fumes and gases can displace air and lower the oxygen level, causing injury or death. Be sure the breathing air is safe.
- Do not weld/cut in locations near degreasing, cleaning, or spraying operations. The heat and rays of the arc can react with vapours to form highly toxic and irritating gases.
- Materials such as galvanised, lead, or cadmium plated steel, containing elements that can give off toxic fumes when welded/cut. Do not weld/cut these materials unless the area is very well ventilated, and or wearing an air-supplied respirator.



Arc rays: harmful to people's eyes and skin. Arc rays from the welding/cutting process produce intense visible and invisible ultraviolet and infrared rays that can burn eyes and skin.

- Always wear a welding helmet with the correct shade of filter lens and suitable protective clothing, including welding gloves while the welding/cutting operation is performed.
- Measures should be taken to protect people in or near the surrounding working area. Use protective screens or barriers to protect others from flash, glare and sparks; warn others not to watch the arc.



Fire hazard. Welding/cutting on closed containers, such as tanks, drums, or pipes, can cause them to explode. Flying sparks from the welding/cutting arc, hot workpiece, and hot equipment can cause fires and burns. Accidental contact of the electrode to metal objects can cause sparks, explosion, overheating, or fire. Check and be sure the area is safe before doing any welding/cutting.

- The welding/cutting sparks & spatter may cause fire, therefore remove any flammable materials well away from the working area. Cover flammable materials and containers with approved covers if unable to be moved from the welding/cutting area.
- Do not weld/cut on closed containers such as tanks, drums, or pipes, unless they are correctly prepared according to the required Safety Standards to ensure that flammable or toxic vapours and substances are totally removed, these can cause an explosion even though the vessel has been "cleaned". Vent hollow castings or containers before heating, cutting or welding. They may explode.
- Do not weld/cut where the atmosphere may contain flammable dust, gas, or liquid vapours (such as petrol)
- Have a fire extinguisher nearby and know how to use it. Be alert that welding/cutting sparks and hot materials from welding/cutting can easily go through small cracks and openings to adjacent areas. Be aware that welding/cutting on a ceiling, floor, bulkhead, or partition can cause a fire on the hidden side.



Gas Cylinders. Shielding gas cylinders contain gas under high pressure. If damaged, a cylinder can explode. Because gas cylinders usually are part of the welding/cutting process, be sure to treat them carefully. CYLINDERS can explode if damaged.

- Protect gas cylinders from excessive heat, mechanical shocks, physical damage, slag, open flames, sparks, and arcs.
- Ensure cylinders are held secure and upright to prevent tipping or falling over.
- Never allow the welding/cutting electrode or earth clamp to touch the gas cylinder, do not drape welding cables over the cylinder.
- Never weld/cut on a pressurised gas cylinder, it will explode and kill you.
- Open the cylinder valve slowly and turn your face away from the cylinder outlet valve and gas regulator.



Gas build-up. The build-up of gas can cause a toxic environment, deplete the oxygen content in the air resulting in death or injury. Many gases use in welding/cutting are invisible and odourless.

- Shut off shielding gas supply when not in use.
- Always ventilate confined spaces or use approved air-supplied respirator.



Electronic magnetic fields. MAGNETIC FIELDS can affect Implanted Medical Devices.

- Wearers of Pacemakers and other Implanted Medical Devices should keep away.
- Implanted Medical Device wearers should consult their doctor and the device manufacturer before going near any electric welding, cutting or heating operation.



Noise can damage hearing. Noise from some processes or equipment can damage hearing.

- Wear approved ear protection if noise level is high.



Hot parts. Items being welded/cut generate and hold high heat and can cause severe burns.

- Do not touch hot parts with bare hands. Allow a cooling period before working on the welding/cutting gun. Use insulated welding gloves and clothing to handle hot parts and prevent burns.

CAUTION

1. Working Environment.

- i. The environment in which this welding/cutting equipment is installed must be free of grinding dust, corrosive chemicals, flammable gas or materials etc., and at no more than a maximum of 80% humidity.
- ii. When using the machine outdoors, protect the machine from direct sunlight, rainwater and snow, etc.; the temperature of the working environment should be maintained within -10°C to +40°C.
- iii. Keep this equipment 30cm distant from the wall.
- iv. Ensure the working environment is well ventilated.

2. Safety Tips.

- i. **Ventilation:** This equipment is small-sized, compact in structure, and of excellent performance in amperage output. The fan is used to dissipate heat generated by this equipment during the welding/cutting operation. Important: Maintain good ventilation of the louvres of this equipment. The minimum distance between this equipment and any other objects in or near the working area should be 30 cm. Good ventilation is of critical importance for the normal performance and service life of this equipment.
- ii. **Thermal Overload Protection:** Should the machine be used to an excessive level, or in a high-temperature environment, poorly ventilated area or if the fan malfunctions the Thermal Overload Switch will be activated, and the machine will cease to operate. Under this circumstance, leave the machine switched on to keep the built-in fan working to bring down the temperature inside the equipment. The machine will be ready for use again when the internal temperature reaches a safe level.
- iii. **Over-Voltage Supply:** Regarding the power supply voltage range of the machine, please refer to the "Main parameter" table. This equipment is of automatic voltage compensation, which enables the maintaining of the voltage range within the given range. In case that the voltage of input power supply amperage exceeds the stipulated value, it is possible to cause damage to the components of this equipment. Please ensure your primary power supply is correct.
- iv. Do not come into contact with the output terminals while the machine is in operation. An electric shock may occur.

MAINTENANCE

Exposure to extremely dusty, damp, or corrosive air is damaging to the welding/cutting machine. To prevent any possible failure or fault of this welding/cutting equipment, clean the dust at regular intervals with clean and dry compressed air of required pressure.

Please note that: lack of maintenance can result in the cancellation of the guarantee; the guarantee of this welding/cutting equipment will be void if the machine has been modified, attempt to take apart the machine or open the factory-made sealing of the machine without the consent of an authorized representative of the manufacturer.

TROUBLESHOOTING

Caution: Only qualified technicians are authorized to undertake the repair of this welding/cutting equipment. For your safety and to avoid Electrical Shock, please observe all safety notes and precautions detailed in this manual.

ATTENTION! - CHECK FOR GAS LEAKAGE

At initial set up and at regular intervals we recommend to check for gas leakage

Recommended procedure is as follows:

1. Connect the regulator and gas hose assembly and tighten all connectors and clamps.
2. Slowly open the cylinder valve.
3. Set the flow rate on the regulator to approximately 8-10 L/min.
4. Close the cylinder valve and pay attention to the needle indicator of the contents pressure gauge on the regulator, if the needle drops away towards zero there is a gas leak. Sometimes a gas leak can be slow and to identify it will require leaving the gas pressure in the regulator and line for an extended time period. In this situation it is recommended to open the cylinder valve, set the flow rate to 8-10 L/min, close the cylinder valve and check after a minimum of 15 minutes.
5. If there is a gas loss then check all connectors and clamps for leakage by brushing or spraying with soapy water, bubbles will appear at the leakage point.
6. Tighten clamps or fittings to eliminate gas leakage.

IMPORTANT! - We strongly recommend that you check for gas leakage prior to operation of your machine. We recommend that you close the cylinder valve when the machine is not in use.

Welding Guns Of Australia PTY LTD, authorised representatives or agents of Welding Guns Of Australia PTY LTD will not be liable or responsible for the loss of any gas.

RAZOR™ 200 PULSE MIG/TIG/STICK Welder

Key Features:

- Single/Double Pulse MIG
- 3-in-1 Multi-process
- 5" Touch Colour LCD
- Synergic Programs
- 4 Geared Wire Drive

3 YEAR
PRODUCT
WARRANTY



TECHNICAL DATA	
SKU	U11003K
PRIMARY INPUT VOLTAGE	240V Single Phase
SUPPLY PLUG	15 AMP
leff (A)	14.9
RATED OUTPUT	40A/16V-200A/24V
PROTECTION CLASS	IP23S
INSULATION CLASS	H
MINIMUM GENERATOR (kVA)	11.0
DINSE CONNECTOR	35/50
STANDARD	AS/NZ60974-1
WELDS	Mild Steel, Stainless Steel, Cast Iron, Silicon Bronze, Aluminium, Copper
WARRANTY (Years)	3

MIG SPECIFICATIONS	
MIG WELDING CURRENT RANGE	40-200A
MIG DUTY CYCLE @ 40°C	15% @ 200A, 60% @ 101A, 100% @ 78A
MIG WIRE SIZE RANGE	0.6-1.2mm
MIG WIRE SPOOL SIZE	1kg / 5kg
MIG WELDING THICKNESS RANGE	1-10mm
DRIVE ROLLER SIZE	30/22

TIG SPECIFICATIONS	
TIG FUNCTION TYPE	High-Frequency
TIG WELDING CURRENT RANGE	5-200A
TIG DUTY CYCLE @ 40°C	20% @ 200A, 60% @ 116A, 100% @ 90A
TIG WELDING THICKNESS RANGE	1-8mm

MMA (STICK) SPECIFICATIONS	
MMA WELDING CURRENT RANGE	20-180A
MMA DUTY CYCLE @ 40°C	15% @ 180A, 60% @ 91A, 100% @ 70A
MMA ELECTRODE RANGE	2.5-4.0mm
MMA WELDING THICKNESS RANGE	2-12mm

SIZE & WEIGHT	
DIMENSIONS (mm)	605x230x400mm
WEIGHT (kg)	17kg

MACHINE FEATURES	
WIRE DRIVE	4 Geared
VRD	Yes
SYNERGIC PROGRAMS	Yes
BURNBACK ADJUSTMENT	Yes
THERMAL OVERLOAD PROTECTION	Yes

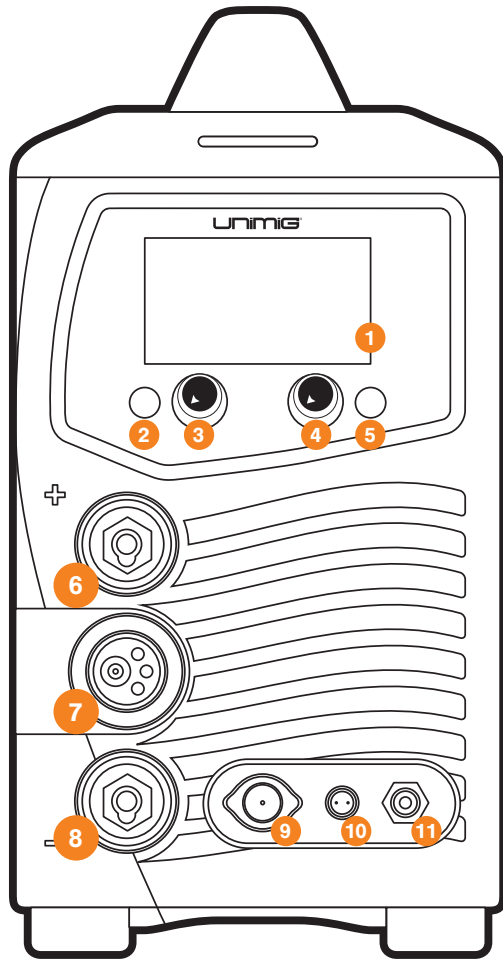

Front Panel Layout

1. Digital Screen
2. "Back" Button
3. Amp / Wire Speed / Scroll Knob
4. Voltage / Arc Length Knob
5. "Menu" Button
6. "+" Output Terminal
7. Euro Connection
8. "-" Output Terminal
9. 12 Pin Socket For Spool Gun
10. 2 Pin Socket For Foot Pedal
11. Gas Outlet

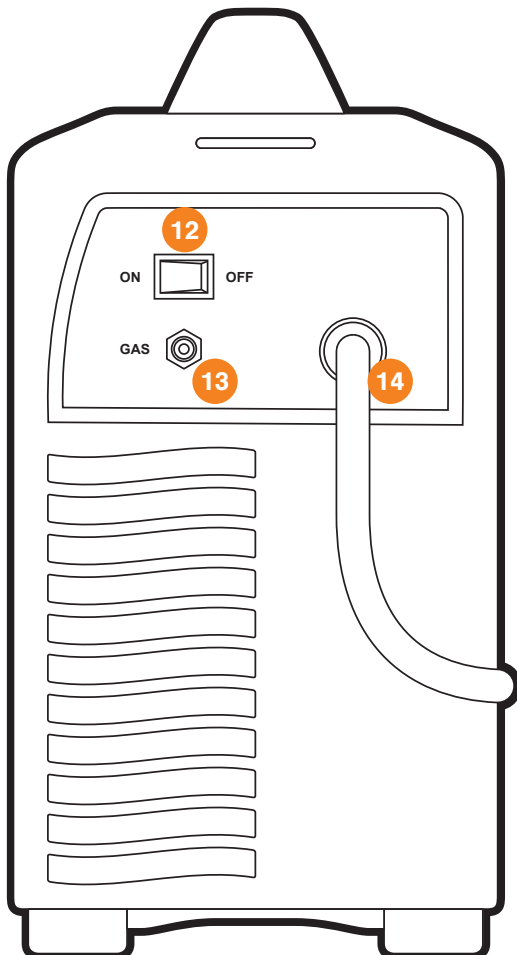

Rear Panel Layout

12. On/Off Switch
13. Gas Inlet
14. Power Cable

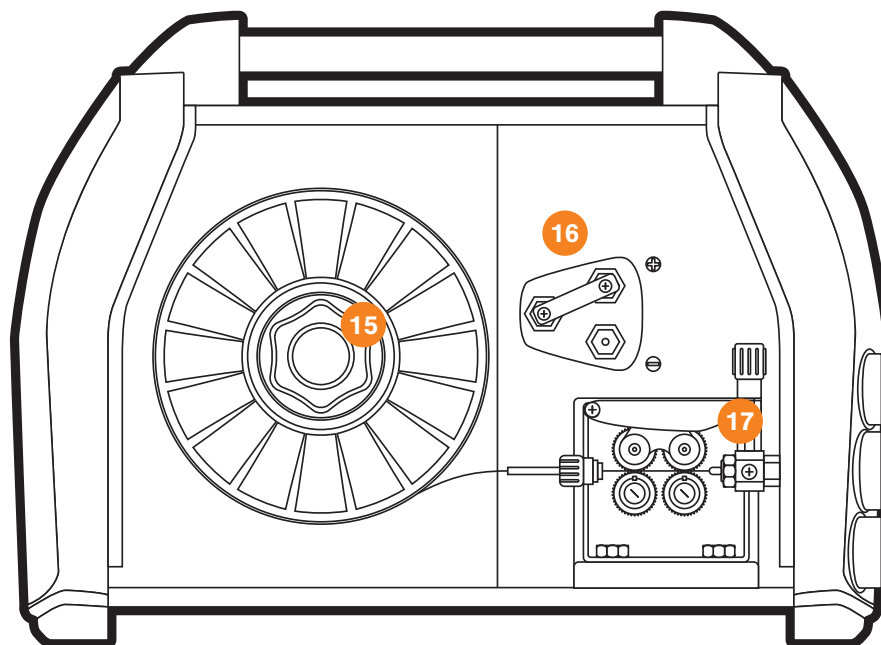

Interior Layout

- 15. Wire Feeding Spool Holder
- 16. Polarity Selector
- 17. 4 Geared Wire Feeder

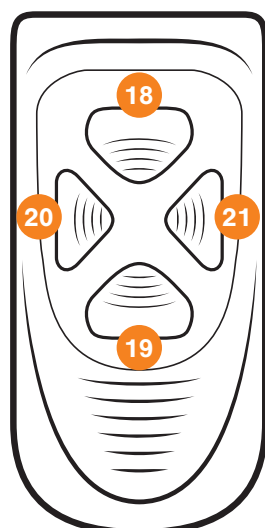

Digital MIG Torch

- 18. Top Button
Synergic: +Increase Current
Manual: +Increase Voltage
- 19. Bottom Button
Synergic: -Decrease Current
Manual: -Decrease Voltage
- 20. Left Button
Synergic: -Decrease Arc Length
Manual: -Decrease Wire Speed
- 21. Right Button
Synergic: +Increase Arc Length
Manual: +Increase Wire Speed

WHAT'S IN THE BOX

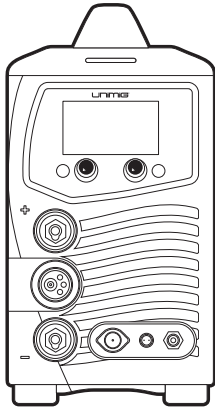

**RAZOR 200 PULSE
MIG/TIG/STICK Welder**



Includes:

- DM26 Consumable Starter Kit

**3m DM26 Digital MIG Torch &
Consumables**

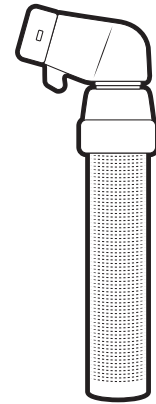

3m Electrode Holder

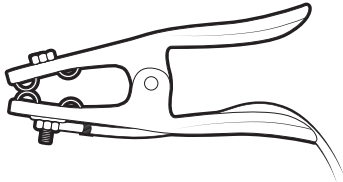

3m 300 AMP Earth Clamp

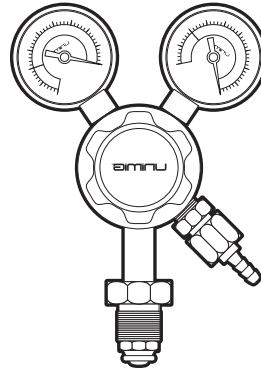

Twin Gauge Argon Regulator

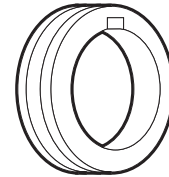

Includes:

- 2 x 0.8-0.9mm "V GROOVE" 30/22
- 2 x 0.8-0.9mm "F GROOVE" 30/22
- 2 x 1.0-1.2mm "U GROOVE" 30/22

Drive Rollers

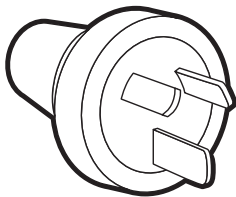

15 AMP Plug (Fitted)



**1.2mm 5356 HYPERMIG
Aluminium Wire 2kg**



Operating Manual

DIGITAL SCREEN - BASIC OPERATION



1. Digital Screen

The digital screen is a **Touch Screen**, you can **Tap** menu items to select and adjust values. You can also **Swipe** on screen to navigate menu items.

2. Back Button

Press the **BACK Button** to return to the previous page. This button can also be pressed to exit a pop up menu.

3. Amp / Wire Speed / Scroll Knob

- i. **Turn** this knob for digital screen navigation and cycling through menu options.
- ii. **Press** this knob in order to confirm actions, between the weld screen and the weld menu parameters.
- iii. In TIG/STICK mode this knob can be used to adjust current.
- iv. In MIG Manual mode this can be used to adjust wire speed.
- v. In MIG Synergic / Pulse mode this can be used to adjust material thickness.

4. Voltage / Arc Length Knob

- i. In TIG mode this knob can be used to adjust weld cycle parameters.
- ii. In MIG Manual mode this knob is used to adjust voltage.
- iii. In MIG Synergic / Pulse mode this can be used to adjust arc length.
- iv. In MMA mode this knob can be used to adjust Arc Force.

5. Menu Button

Press the **MENU Button** to enter the main menu.

DIGITAL SCREEN - MACHINE SETTINGS MENU

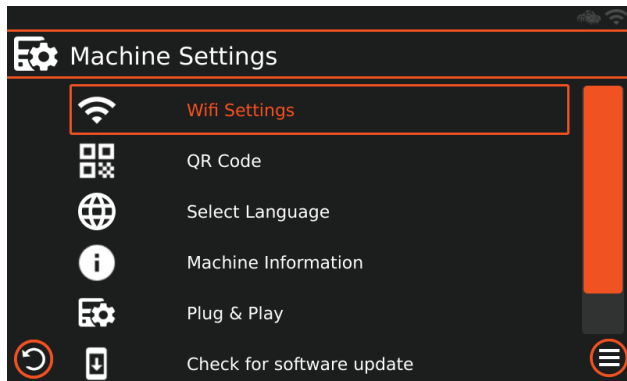

1. **Wifi Settings**
2. **QR Code**
3. **Select Language**
4. **Machine Information**
5. **Plug & Play**
6. **Check for software update**

Press the **≡ MENU** button to enter the main menu. The following options are available in the menu.

1. Wifi Settings

Select or change your current WiFi network. Select your WiFi network and follow the prompts to connect to the network. You will need to enter the WiFi network password. The screen will display a touch screen keyboard which will allow you to input the password.

2. QR Code

The QR Code enables fast identification of your machine.

3. Select Language

Choose desired language from this menu.

4. Machine Information

View your machine identification information, including:

- Serial Number
- Machine Model
- Firmware Version
- HMI Version

5. Plug & Play

Enable/Disable additional torch modules from here.

6. Check for software update

Update the **Firmware** and the **HMI Firmware**.

- Select **Check** to check for the latest updates. You will need to be connected to a WiFi network to receive updates.
- If a new update is available, select **Update** to initiate a firmware update.
- If you are experiencing issues after updating firmware, select **Recovery Firmware** to restore the firmware to an earlier version.

DIGITAL SCREEN - MIG

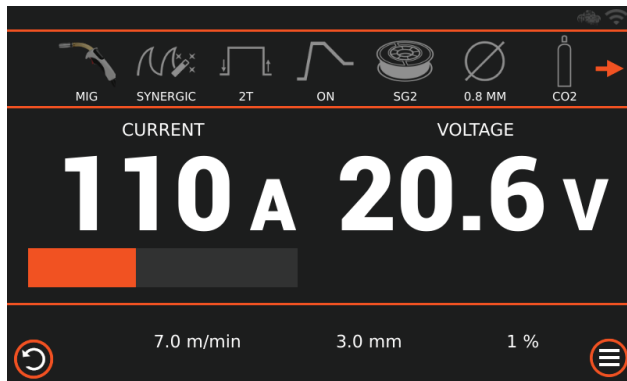

1. **MIG Settings**
2. **Advanced MIG Settings**

1. MIG Settings

MIG Type

Select the desired welding mode.

MIG Type	Description
Manual	Standard MIG controls, set your parameters by adjusting Wire Speed and Voltage.
Synergic	Machine will calculate optimal settings based on your selected Wire / Gas / Material Thickness.
Pulse	Single Pulse MIG alternates between the Peak Current and the Low Current.
Double Pulse	Double Pulse is two pulses that happen simultaneously. The first pulse is your standard pulse with a Peak Current and a Base Current. The second pulse, which doesn't transfer any wire, turns the first pulse on and off.

Torch Mode

Select the desired torch mode.

Torch Mode	Description
2T	2T (two touch) means you will need to hold the trigger down on your MIG torch while you weld.
4T	In 4T (four touch) mode, you will only need to click the trigger to ignite the arc and the torch will continue to weld until you click it again to turn it off.
SPOT	SPOT mode is consecutive and evenly timed arcs that work well if you want perfectly even tacks and small welds.

Wire/Gas (Synergic / Pulse / Double Pulse)

Select the desired wire and gas mixture.

	Wire Diameter					Gas Mixture					
	0.6mm	0.8mm	0.9mm	1.0mm	1.2mm	CO2	80/20%	92/8%	97.5/2.5%	98/2	Ar
SG2 (MILD STEEL)		✓	✓			✓	✓	✓			
CRNI (STAINLESS STEEL)		✓	✓						✓	✓	
ALMG5 (AM5356)				✓	✓						✓
ALS15 (AM4043)					✓						✓
CUS13 (SILICON BRONZE)		✓	✓								✓

2. Advanced MIG Settings

MIG - Manual

Setting	Values	Description
Inductance	±10	Set how fast the current rises to reach the amps that have been selected when welding.
Burnback Adjustment	±10	Set how far the wire will burn back once the torch trigger has been released.
Pregas Timer	0.1 - 3s	Set how long you would like your gas to flow before the arc ignites.
Postgas Timer	0.1 - 3s	Set how long you would like your gas to flow after the arc ends.
GLICK Level	20-90% / Off	The GLICK function allows you to trim output current during 4T MIG operation by tapping the torch's switch when a 4T welding cycle is ongoing. This allows for a more refined control of the heat input for long-range welding, giving you more options in weld bead formation. (4T only)
Spot Timer	0.5 - 25s	Set the length of time to run the SPOT function.

MIG - Synergic

Setting	Values	Description
Hot Start	Off - On	Hot Start provides an initial burst of current, improving the arc ignition and greatly reducing the chance of sticking.
Hot Start Current	20 - 150%	Set the Hot Start Current.
Hot Start Timer	0 - 10s	Set the Hot Start Timer (2T only).
Hot Start Slope	0 - 10s	Set the Hot Start Slope.
Inductance	±10	Set how fast the current rises to reach the amps that have been selected when welding.
Burnback Adjustment	±10	Set how far the wire will burn back once the torch trigger has been released.
Pregas Timer	0.1 - 3s	Set how long you would like your gas to flow before the arc ignites.
Stop Slope	0 - 20s	Set how long it takes for the Peak Current to reach the Stop Current.
Stop Current	20 - 80%	Set the Stop Current to adjust how hot your weld will finish.
Stop Timer	0 - 10s	Set how long the Stop Current lasts.
Postgas Timer	0.1 - 3s	Set how long you would like your gas to flow after the arc ends.

MIG - Pulse

Setting	Values	Description
Start Force	0 - 10	Set the Start Force value.
Hot Start	Off - On	Hot Start provides an initial burst of current, improving the arc ignition and greatly reducing the chance of sticking.
Hot Start Current	20 - 150%	Set the Hot Start Current.
Hot Start Timer	0 - 10s	Set the Hot Start Timer (2T only).
Hot Start Slope	0 - 10s	Set the Hot Start Slope.
Inductance	±10	Set how fast the current rises to reach the amps that have been selected when welding.
Burnback Adjustment	±10	Set how far the wire will burn back once the torch trigger has been released.
Pregas Timer	0.1 - 3s	Set how long you would like your gas to flow before the arc ignites.
Stop Slope	0 - 20s	Set how long it takes for the Peak Current to reach the Stop Current.
Stop Current	20 - 80%	Set the Stop Current to adjust how hot your weld will finish.
Stop Timer	0 - 10s	Set how long the Stop Current lasts.
Postgas Timer	0.1 - 3s	Set how long you would like your gas to flow after the arc ends.

MIG - Double Pulse

Setting	Values	Description
Start Force	0 - 10	Set the Start Force value.
Hot Start	Off - On	Hot Start provides an initial burst of current, improving the arc ignition and greatly reducing the chance of sticking.
Hot Start Current	20 - 150%	Set the Hot Start Current.
Hot Start Timer	0 - 10s	Set the Hot Start Timer (2T only).
Hot Start Slope	0 - 10s	Set the Hot Start Slope.
Inductance	±10	Set how fast the current rises to reach the amps that have been selected when welding.
Burnback Adjustment	±10	Set how far the wire will burn back once the torch trigger has been released.
Pregas Timer	0.1 - 3s	Set how long you would like your gas to flow before the arc ignites.
Double Pulse Frequency	0.5 - 5Hz	Set the frequency of the Double Pulse function.
Double Pulse Mode	Standard - Advanced	Choose between Standard or Advanced settings adjustments for Double Pulse.
Double Pulse Low Current	10 - 90%	Set the Double Pulse Low Current.
Double Pulse Balance	10 - 90%	Set the Double Pulse Low Balance.
Stop Slope	0 - 20s	Set how long it takes for the Peak Current to reach the Stop Current.
Stop Current	20 - 80%	Set the Stop Current to adjust how hot your weld will finish.
Stop Timer	0 - 10s	Set how long the Stop Current lasts.
Postgas Timer	0.1 - 3s	Set how long you would like your gas to flow after the arc ends.

DIGITAL SCREEN - TIG

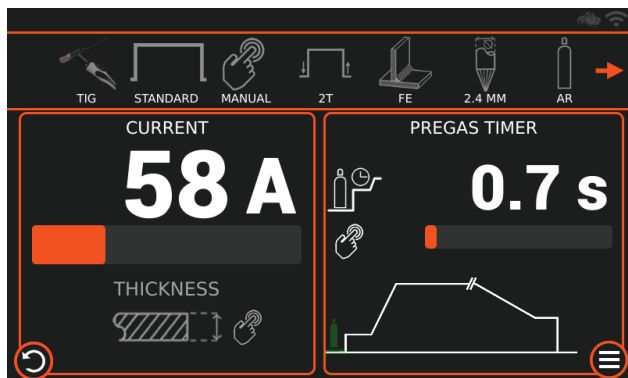

1. TIG Settings
2. Advanced TIG Settings

1. TIG Settings

TIG Type

Select the desired TIG type.

TIG Type	Description
Standard	Standard TIG welding.
Pulse	Pulse TIG alternates between the Peak Current and the Base Current.
Mix	Mix TIG adds a vibration into the weld cycle to aid in welding larger gaps in the workpiece.

Weld Mode

Select the desired mode.

Torch Mode	Description
Manual	Standard TIG controls, set your parameters by adjusting Current and Weld Cycle.
Synergic	Machine will calculate optimal settings based on your selected Wire / Gas / Material Thickness.

Cycle

Select the desired Torch Cycle.

Torch Cycle	Description
2T	2T (two touch) means you will need to hold the button down on your High Frequency torch while you weld.
4T	In 4T (four touch) mode, you will only need to click the button to ignite the arc and the torch will continue to weld until you click it again to turn it off.
SPOT	SPOT mode is consecutive and evenly timed arcs that work well if you want perfectly even tacks and small welds.

Wire/Gas (Synergic)

Select the desired wire and gas mixture.

	Wire Diameter		Gas Mixture
	1.6mm	2.4mm	Ar
FE (MILD STEEL)	✓	✓	✓
CRNI (STAINLESS STEEL)	✓	✓	✓
TITANIUM	✓	✓	✓

2. Advanced TIG Settings

TIG - Manual

Setting	Values	Description
HF Switch	Off - On	Set whether to use High Frequency start. To use button controls on a torch, you'll need HF ON.
Pregas Timer	0.1 - 10s	Set how long you would like your gas to flow before the arc ignites.
Start Current	20 - 150%	Set the starting current when the arc ignites.
Start Timer	0 - 10s	Set how long the Start Current lasts.
Start Slope	0 - 10s	Set how long it takes for the Start Current to reach the Peak Current.
Stop Slope	0 - 20s	Set how long it takes for the Peak Current to reach the Stop Current.
Stop Current	20 - 80%	Set the Stop Current to adjust how hot your weld will finish.
Stop Timer	0 - 10s	Set how long the Stop Current lasts.
GLICK Level	20%-90% - Off	The GLICK function allows you to trim output current during 4T TIG operation by tapping the torch's switch when a 4T welding cycle is ongoing. This allows for a more refined control of the heat input for long-range welding, giving you more options in weld bead formation. (4T only)
Postgas Timer	0.5 - 25s	Set how long you would like your gas to flow after the arc ends.

TIG - Pulse

Setting	Values	Description
Pulse Frequency	0.5 - 1000Hz	Set the number of pulses per second.
Pulse Balance	25 - 75%	Set the percentage of each pulse spent in Peak Current.
Pulse Softness	Off - On	Turn Off/On to adjust the sound of the weld.
Pulse Low Current	20 - 80%	Set the Low Current of the pulse.

TIG - Mix

Setting	Values	Description
Mix Frequency	0.1 - 5Hz	Set the frequency of the Mix cycle. A higher value is recommended for fillet welds, a lower value is recommended for butt welds.
Mix Balance	80 - 95%	Set the percentage of the Mix vibration of the weld cycle.
Mix Softness	Off - On	Turn Off/On to adjust the sound of the weld.

DIGITAL SCREEN - STICK

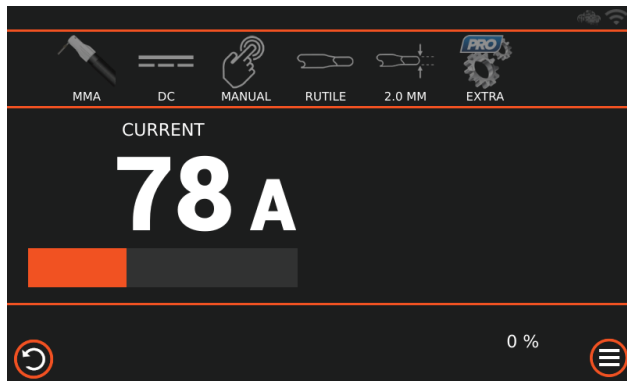

1. **STICK Settings**
2. **Advanced STICK Settings**

1. STICK Settings

Weld Mode

Select the desired mode.

Torch Mode	Description
Manual	Standard MMA controls, set your parameters by adjusting Current and Arc Force.
Synergic	Machine will calculate optimal settings based on your selected Electrode / Material Thickness.

Electrode

Select the desired electrode.

Electrode	Description
RUTILE	These electrodes have a high percentage of titanium oxide (rutile) in their coating. The HYPERARC General Purpose 6013 is a rutile electrode.
SST	Stainless Steel electrodes, match the grade of Stainless Steel to your base material.
BASIC	These electrodes have a high percentage of limestone and fluorspar in their coating. Low Hydrogen electrodes, like the HYPERARC 16TC Low Hydrogen Electrode, are basic electrodes. These are used often in critical welds.
CELLULOSIC	These electrodes have a high percentage cellulose in their coating. They're known for being deeply penetrative (aggressive) electrodes, which is helped by the wood and paper fibres also in the flux. Some examples include the 6010 & 6011 electrodes.

Electrode Diameter

Select the desired electrode size.

- 2.0mm
- 2.5mm
- 3.2mm
- 4.0mm

Arc Force

🔄 Turn the **Voltage / Arc Length Knob** to adjust the Arc Force (0-100%).

2. Advanced STICK Settings

Setting	Values	Description
Power Limit Off/On	Off/On	Set Power Limit Off or On.
Power Limit	0 - 100%	Set Power Limit value.
Anti-sticking	Off/On	Set Anti-sticking Off or On.

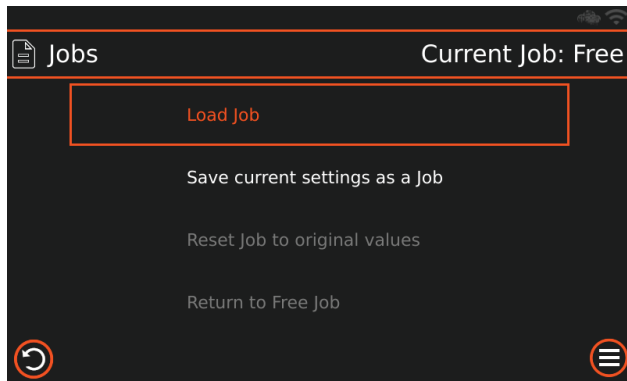

- 1. Load job**
- 2. Save Current Settings as a Job**
- 3. Reset Job to original values**
- 4. Return to Free Job**

Up to 100 saved jobs can be stored with the RAZOR 200 PULSE's Job feature. The Jobs menu can be accessed from the top settings menu in MIG and TIG modes.

1. Load Job

Select **Load Job** to open up the list of saved jobs. These jobs can be filtered by material, wire diameter, gas type or your inputted description. Simply select and confirm the desired job to load the settings.

2. Save Current Settings as a Job

Select **Save Current Settings as a Job** to save your current settings. Enter the job number from an available slot, then add an optional description for the job.

You can also overwrite an existing job by selecting the **Save Current Settings as a Job** option while a current job has been loaded and settings have been altered. Select the **Overwrite Current Job** option to confirm.

3. Reset Job to original values

If you have changed settings of a job and wish to reset the settings back to the original saved values, simply select the **Reset Job to original values** option.

4. Return to Free Job

If you wish to exit the saved jobs and return to free settings, simply hit the **Return to Free Job** option. You will get the choice to carry over your saved settings into Free Job mode, or set the machine settings back to default.

SETUP FOR MIG (GASLESS)

1 Connect the polarity connector to the **negative (-)** connection, unscrew the bolt and move the connector, then screw and tighten in place.

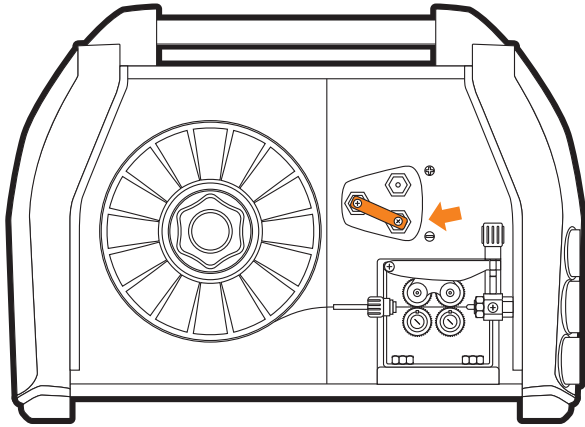

2 Connect the earth clamp to the **positive (+)** dinse connection, twist to lock in place.

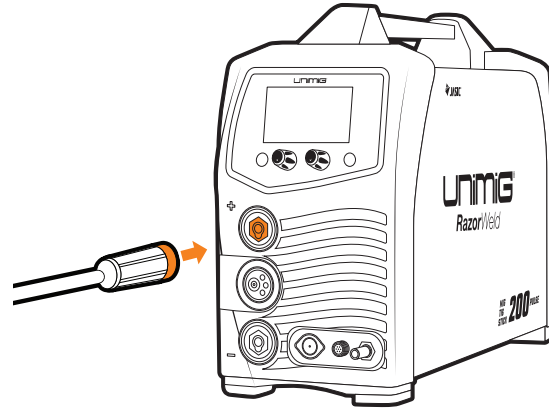

3 Connect the MIG torch to the Euro connection and twist end to secure in place.

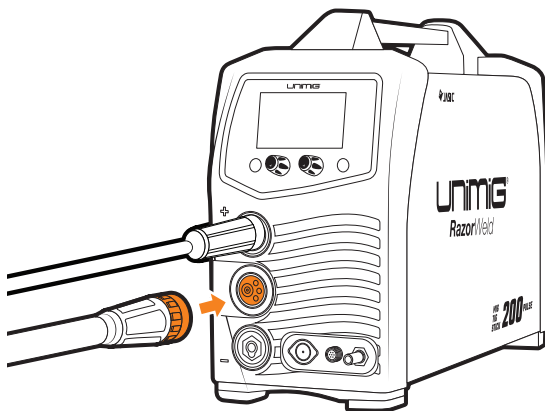

4 Connect the plug into a 15 AMP socket, then switch the machine ON.

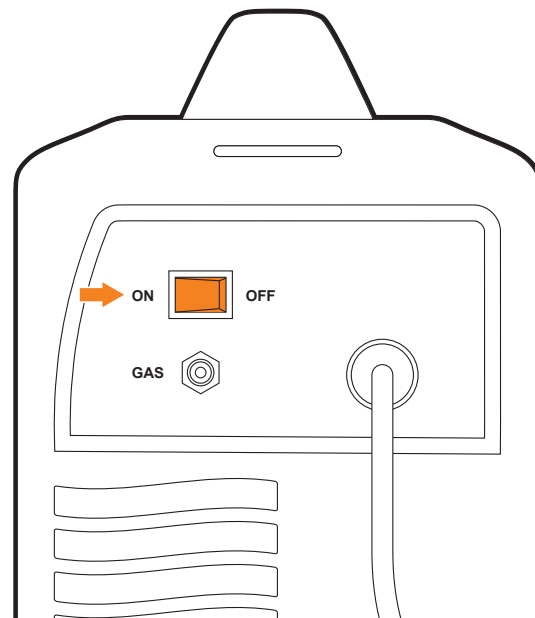

SETUP FOR MIG (GASLESS)

5 Pull down the roller tension knob to release the wire drive.

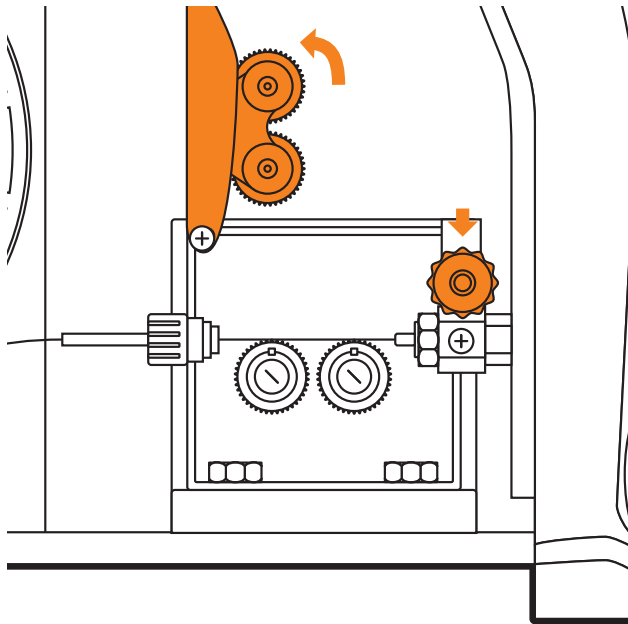

6 Unscrew both roller caps.

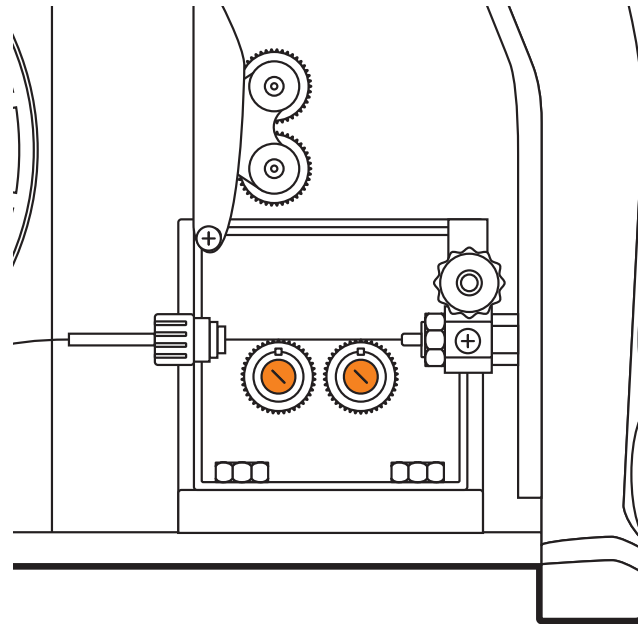

7 Ensure you have Knurled (F Groove) drive rollers installed. If not, fit correct rollers and replace the roller covers.

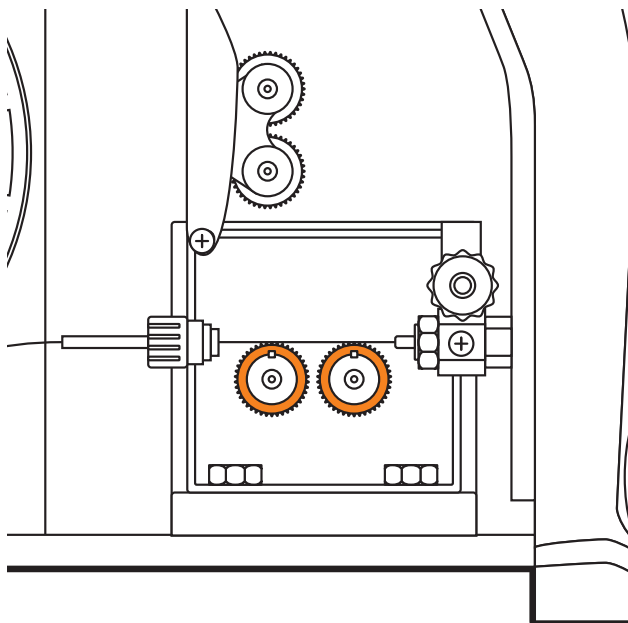

8 Unscrew spool retaining nut.

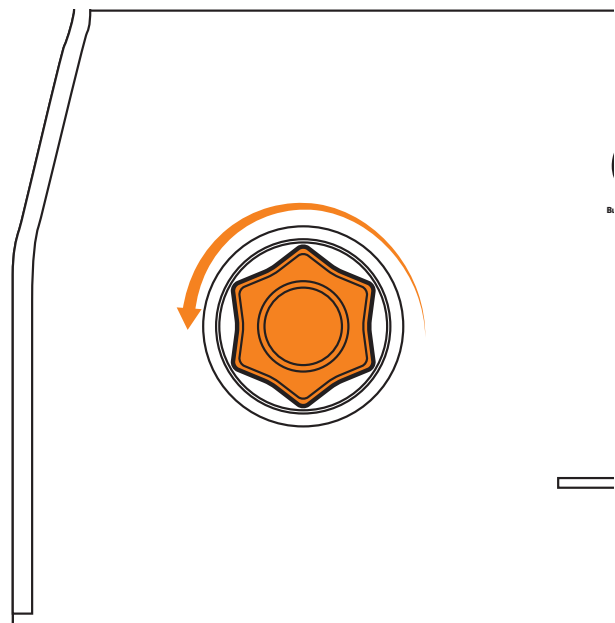

SETUP FOR MIG (GASLESS)

9 Place 5kg wire spool onto the spool holder. For 1kg spool, see step 19.

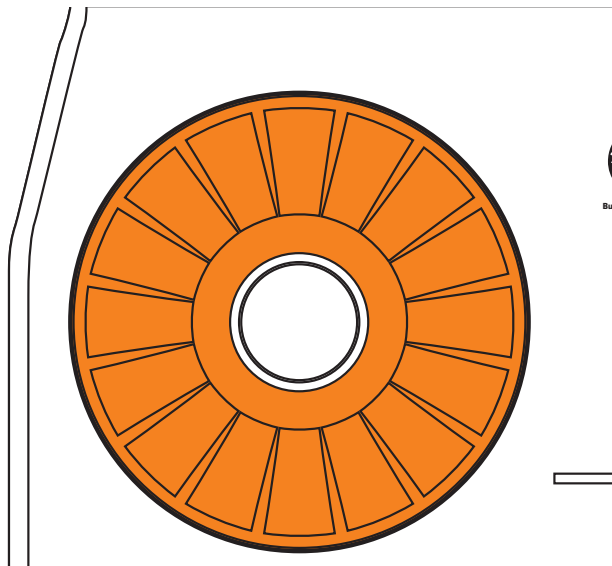

10 Tighten spool retaining nut.

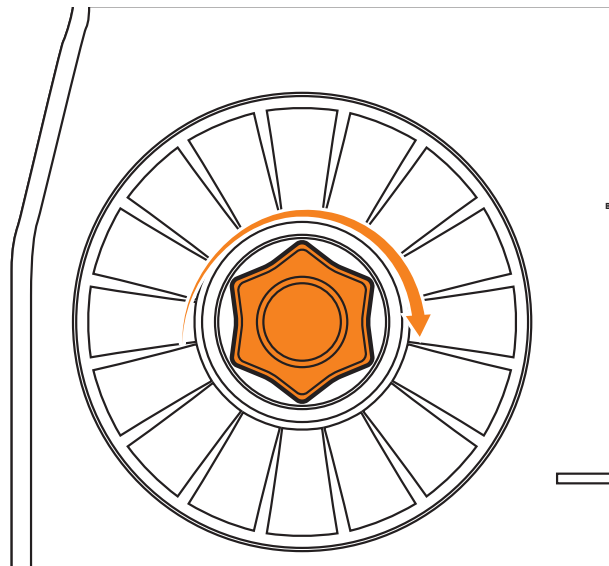

11 Feed wire through the inlet guide tube through to the outlet guide tube. Ensure that the wire passes through the roller.

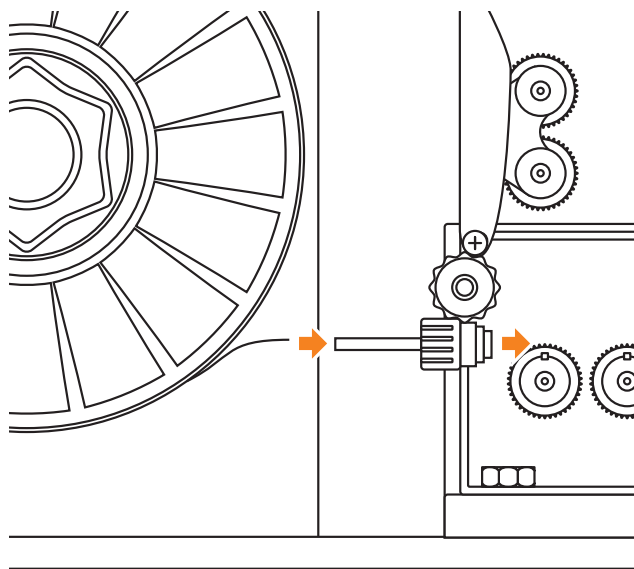

12 Lift roller tension knob to lock wire in place. Twist to tighten.

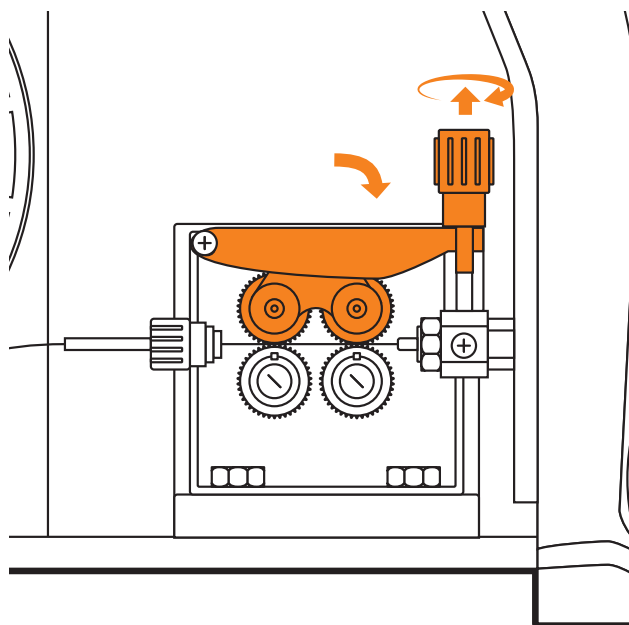

SETUP FOR MIG (GASLESS)

- 13** Remove front end consumables from the MIG torch.

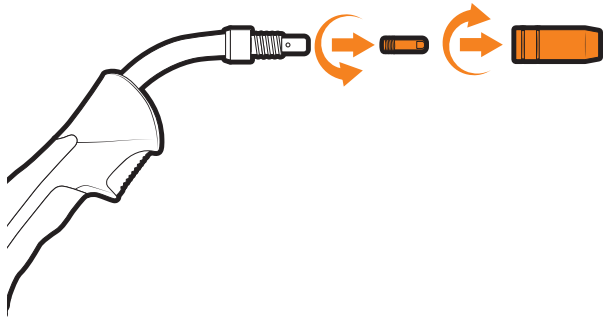

- 14** Hold the torch trigger for 5s until the "INCH WIRE" message appears on the digital screen. Release the torch trigger then hold trigger again immediately to feed wire through to the torch. If the wire slips or stops you will need to adjust the roller tension knob.

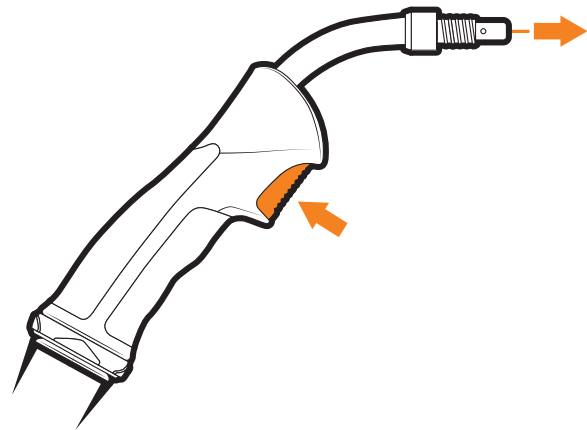

- 15** Replace front end consumables on the MIG torch.

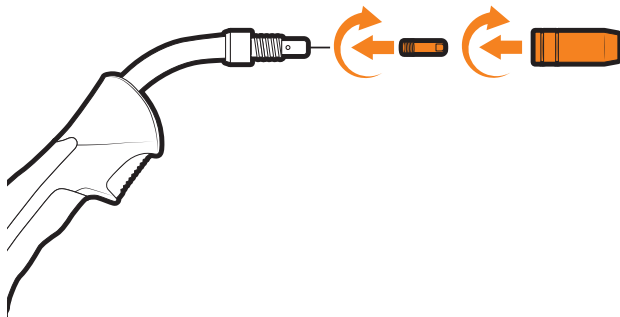

- 16** Connect earth clamp to your workpiece.

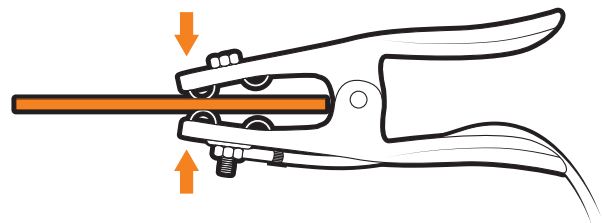

SETUP FOR MIG (GASLESS)

17 Set weld parameters on the digital screen. See "Digital Screen - MIG" on page 14.

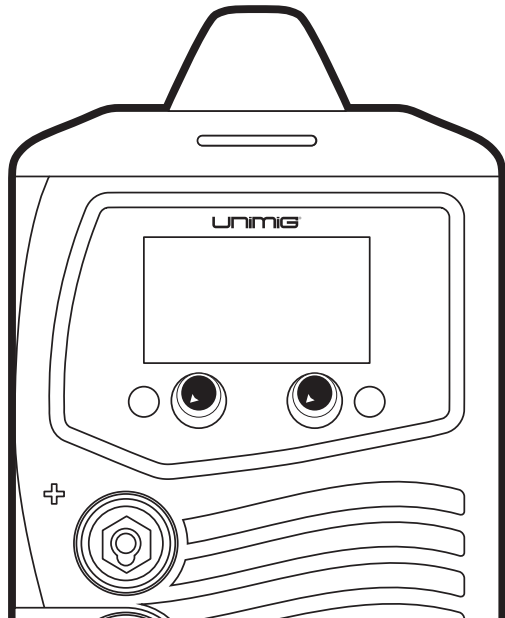

18 Line up the torch with your workpiece, then simply pull the trigger to initiate the weld. For gasless MIG, the drag method is recommended for optimum weld quality. Release trigger to end the weld.

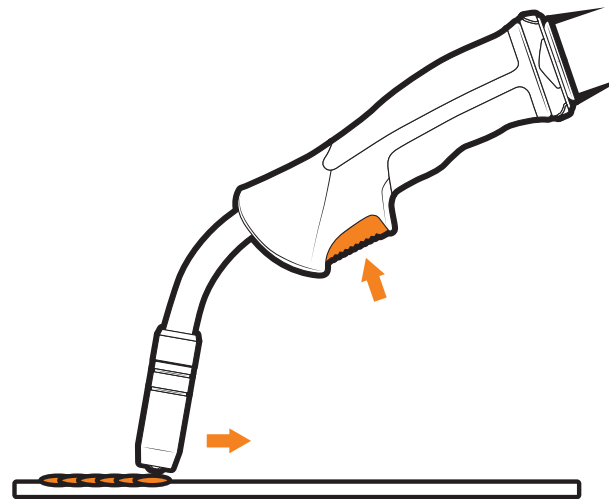

19 **For 1kg spool:** After removing spool holder nut, unscrew the 1kg spool bolt located inside the spool holder housing.

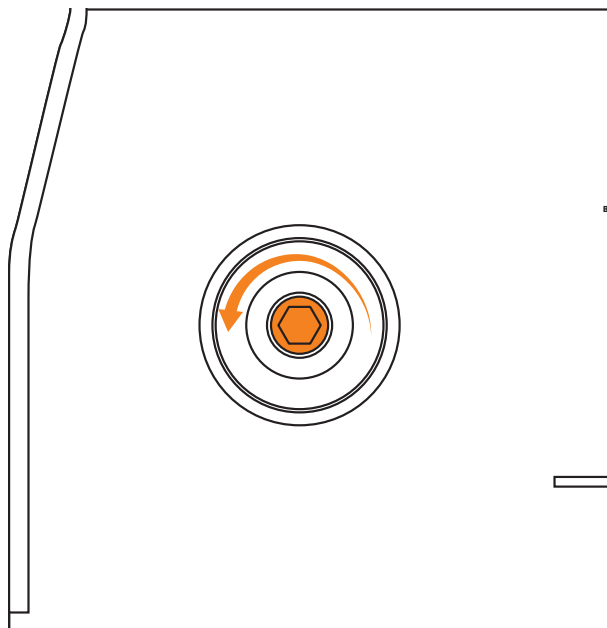

20 **For 1kg spool:** Remove spool holder housing and spring. Place 1kg spool housing inside the square hole where the spool housing is removed from. The 1kg housing is found on the inside of the main spool holder housing.

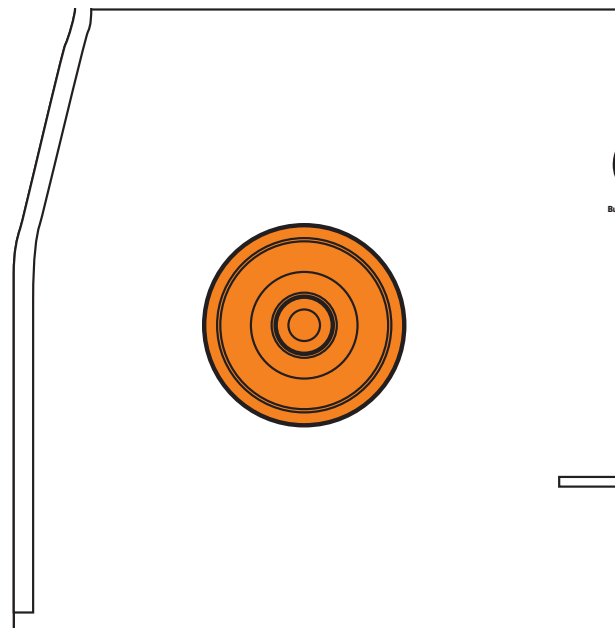

SETUP FOR MIG (GASLESS)

- 21** **For 1kg spool:** Place 1kg spool over 1kg spool housing, then tighten and secure with 1kg spool bolt and nut.

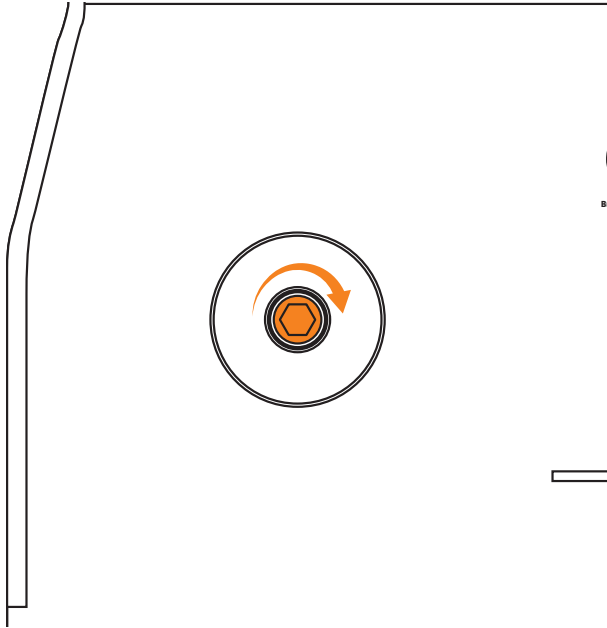

SETUP FOR MIG (GAS-SHIELDED)

1 Connect the polarity connector to the **positive (+)** connection, unscrew the bolt and move the connector then screw and tighten in place.

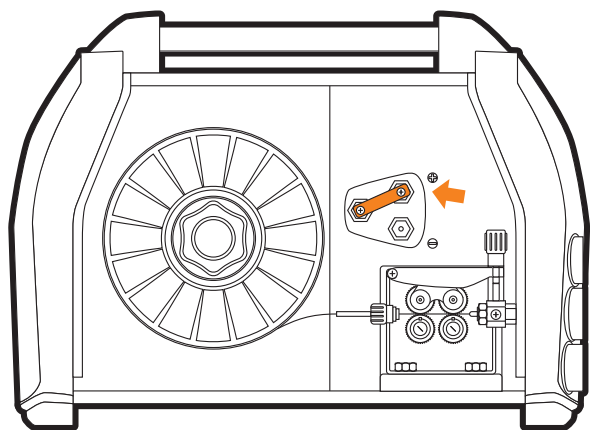

2 Connect the earth clamp to the **negative (-)** dinse connection, twist to lock in place.

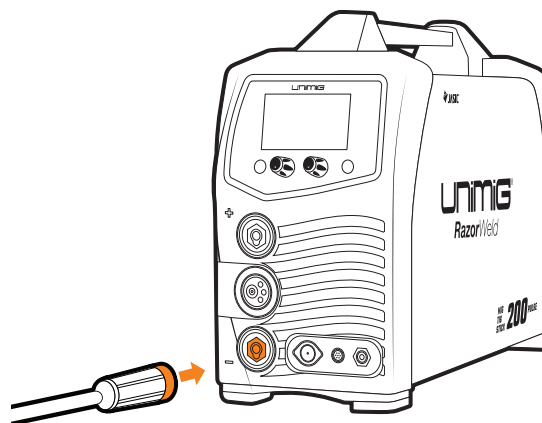

3 Connect the MIG torch to the Euro connection and twist end to secure in place.

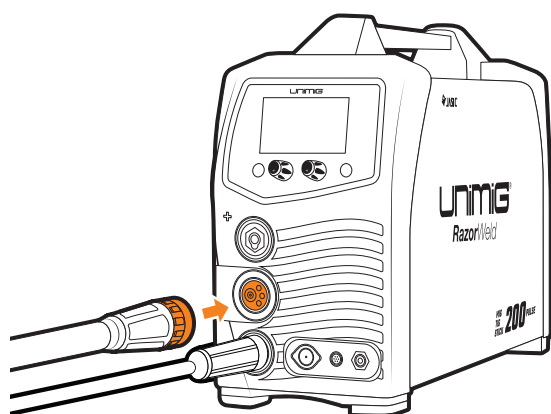

4 Connect the plug into a 15 AMP socket, then switch the machine ON.

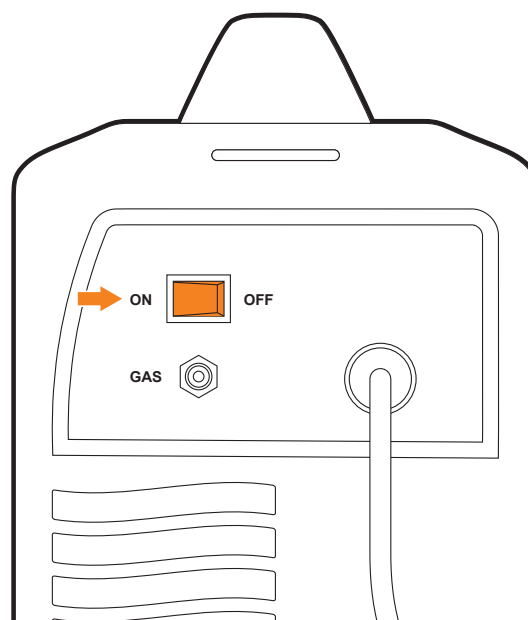

SETUP FOR MIG (GAS-SHIELDED)

- 5** Pull down the roller tension knob to release the wire drive.

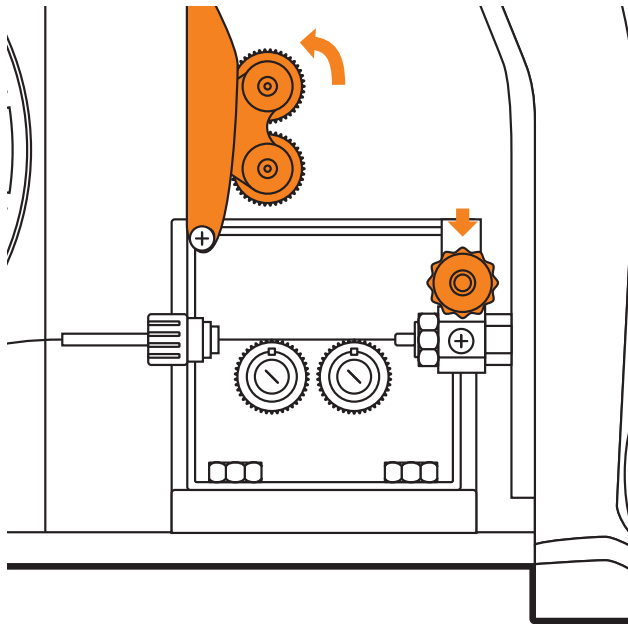

- 6** Unscrew both roller caps.

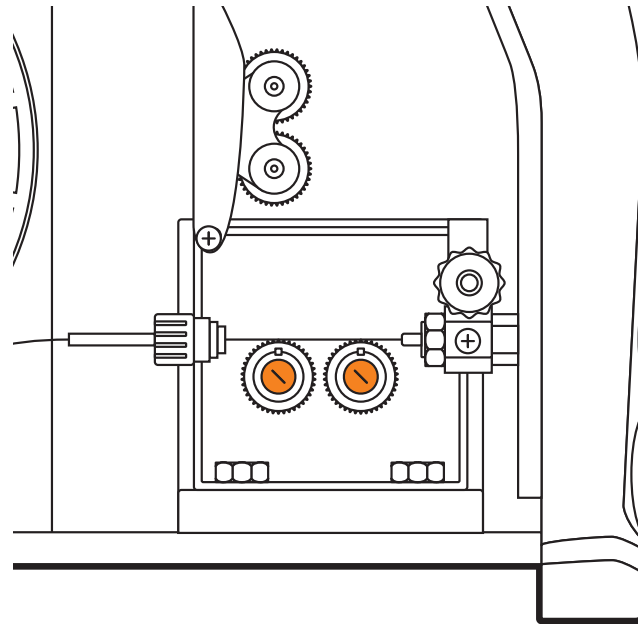

- 7** Ensure you have V Groove drive rollers installed. If not, fit correct rollers and replace the roller covers.

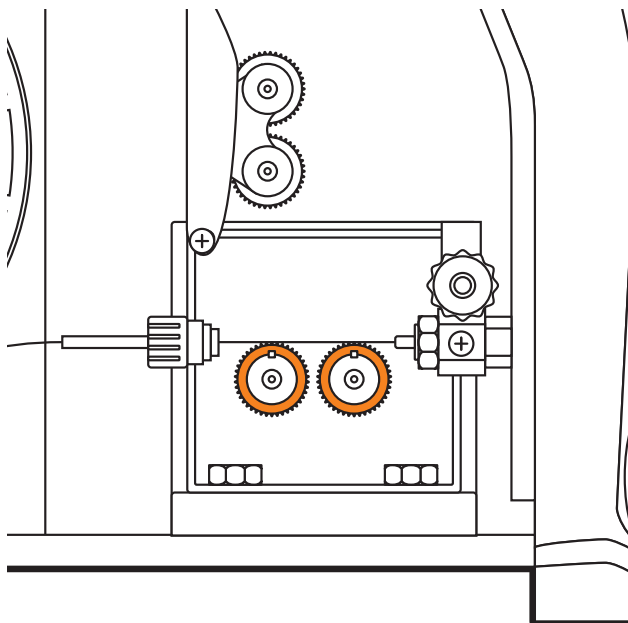

- 8** Unscrew the roller cap.

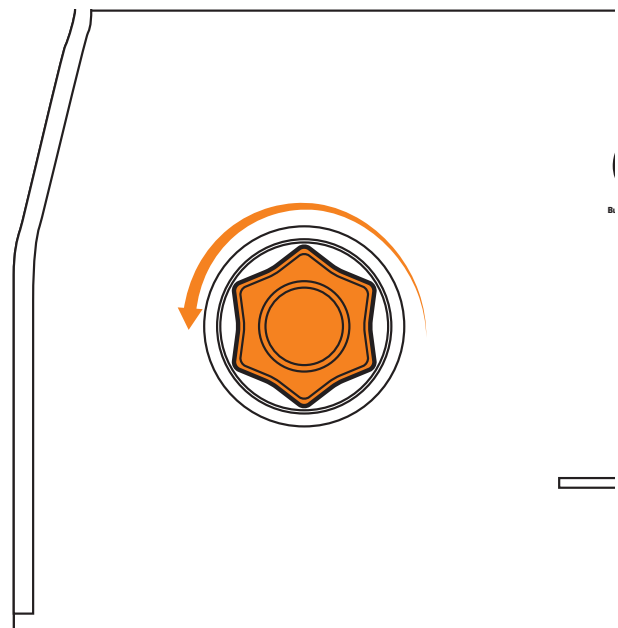

SETUP FOR MIG (GAS-SHIELDED)

9 Place 5kg wire spool onto the spool holder. For 1kg spool, see step 24.

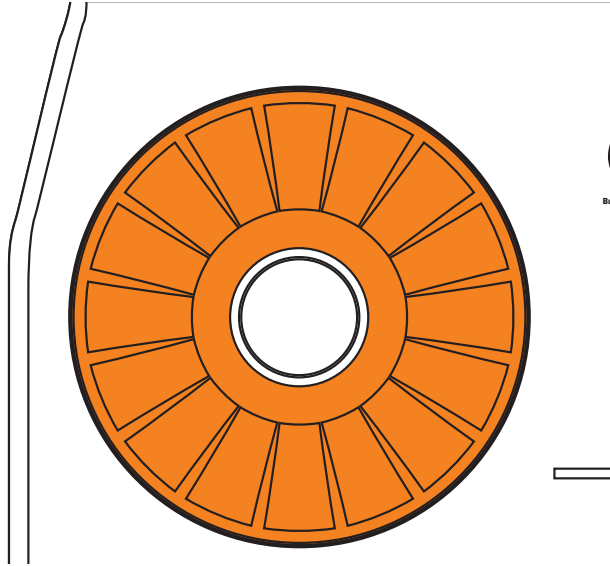

10 Tighten spool retaining nut.

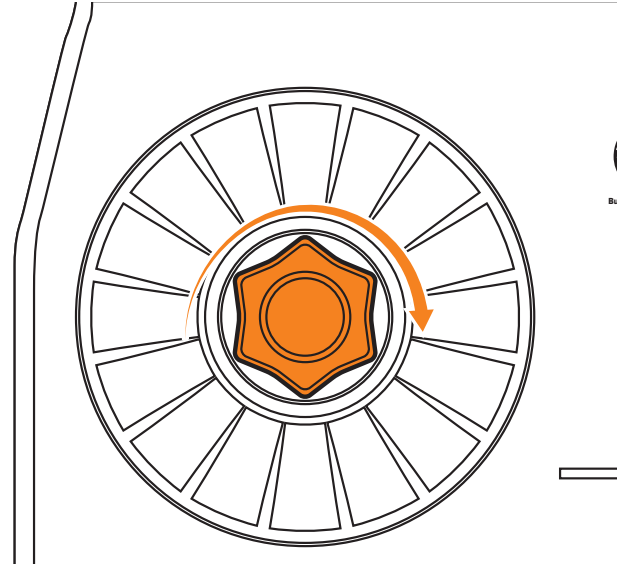

11 Feed wire through the inlet guide tube through to the outlet guide tube. Ensure that the wire passes through the roller.

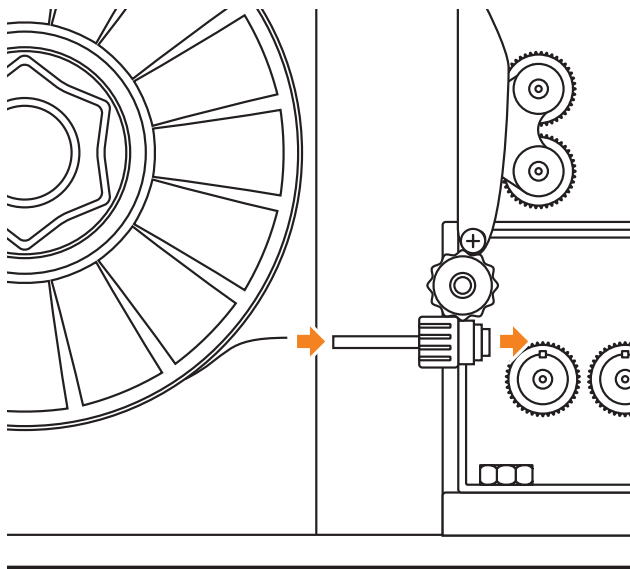

12 Lift roller tension knob to lock wire in place. Twist to tighten.

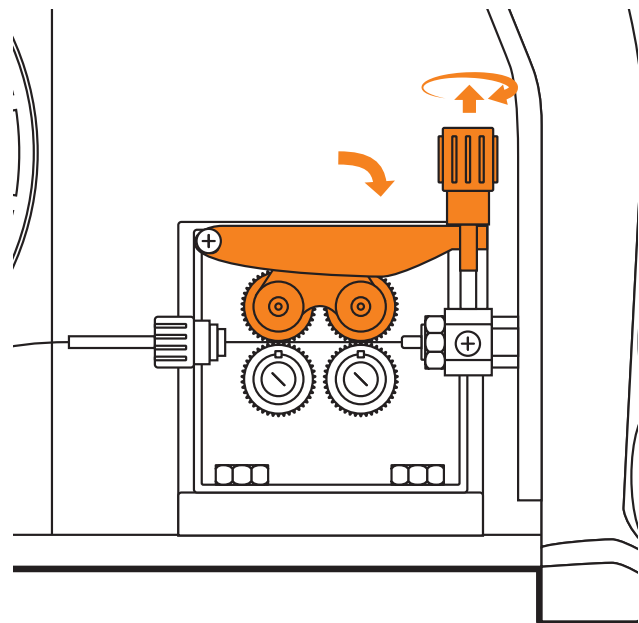

SETUP FOR MIG (GAS-SHIELDED)

- 13** Remove front end consumables from the MIG torch.

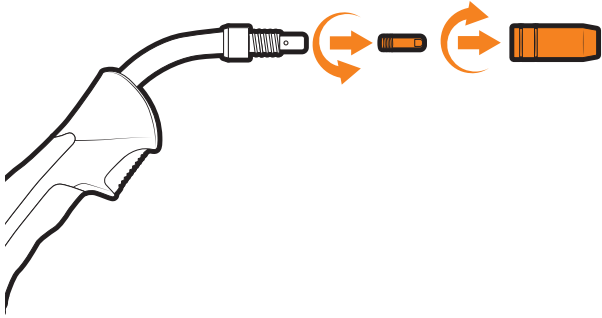

- 14** Hold the torch trigger for 5s until the "INCH WIRE" message appears on the digital screen. Release the torch trigger then hold trigger again immediately to feed wire through to the torch. If the wire slips or stops you will need to adjust the roller tension knob.

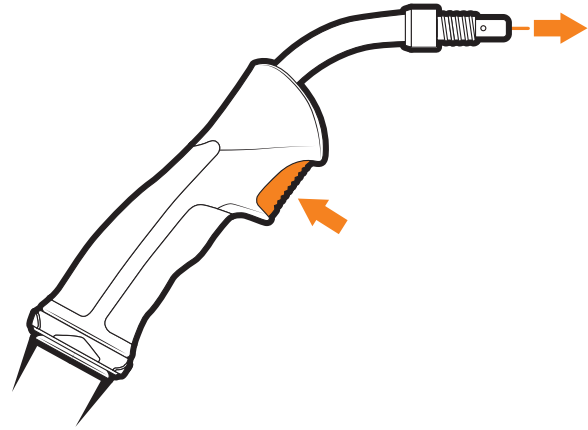

- 15** Replace front end consumables on the MIG torch.

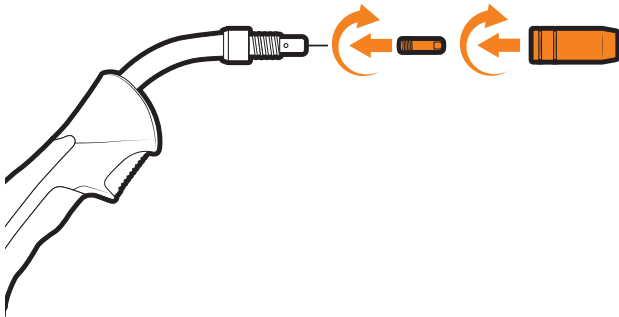

- 16** Place twin gauge argon regulator into your gas outlet.

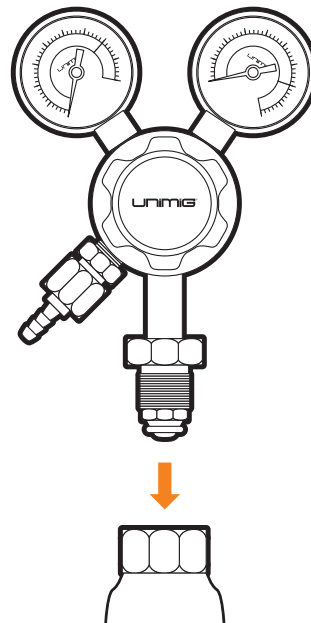

SETUP FOR MIG (GAS-SHIELDED)

17 Tighten securely with wrench.

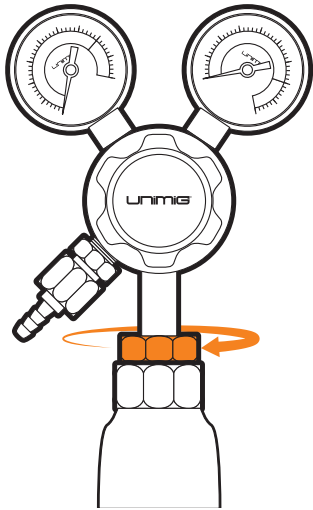

18 Connect gas hose to the regulator outlet, and crimp in place.

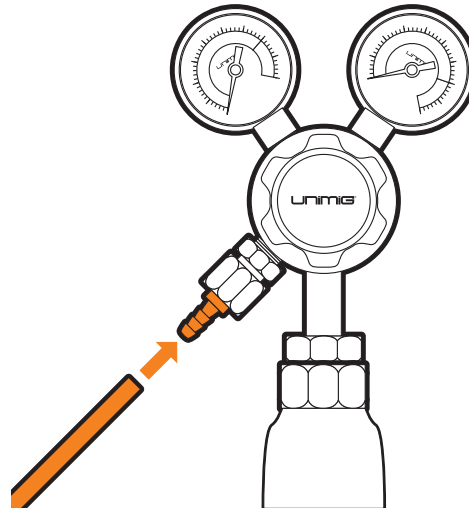

19 Adjust gas flow to 8-12L/min.

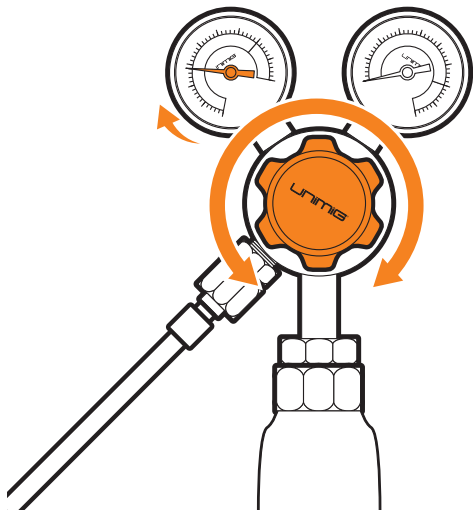

20 Connect gas hose to the gas inlet on the rear of the machine.

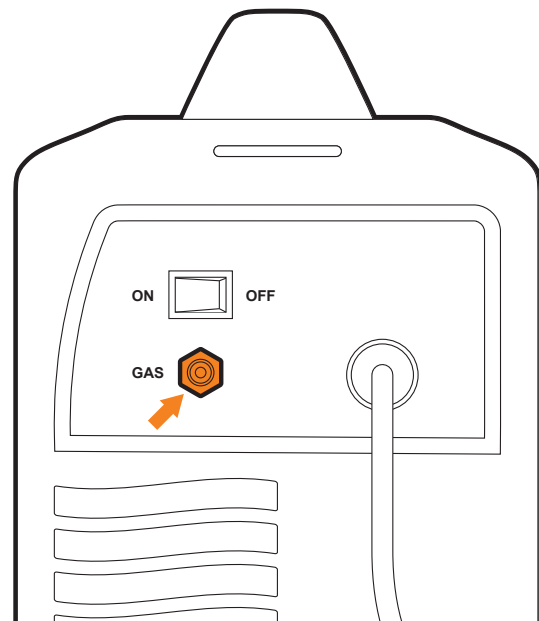

SETUP FOR MIG (GAS-SHIELDED)

21 Connect earth clamp to your workpiece.

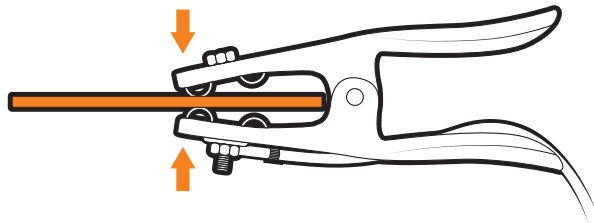

22 Set weld parameters on the digital screen. See "Digital Screen - MIG" on page 14.

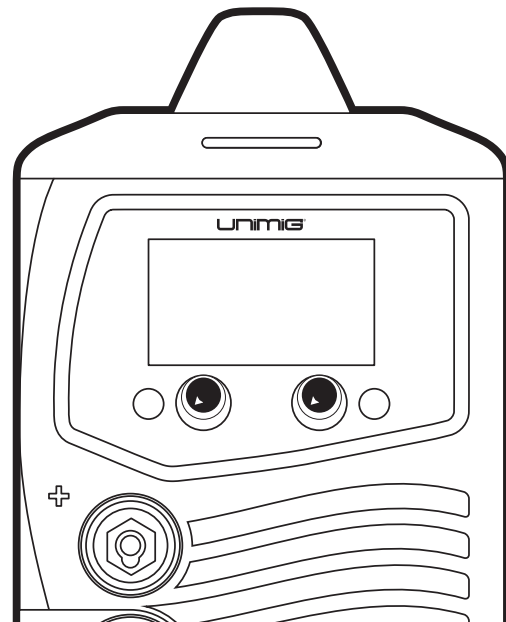

23 Line up the torch with your workpiece, then simply pull the trigger to initiate the weld. For gas-shielded MIG, the push method is recommended for optimum weld quality. Release trigger to end the weld.

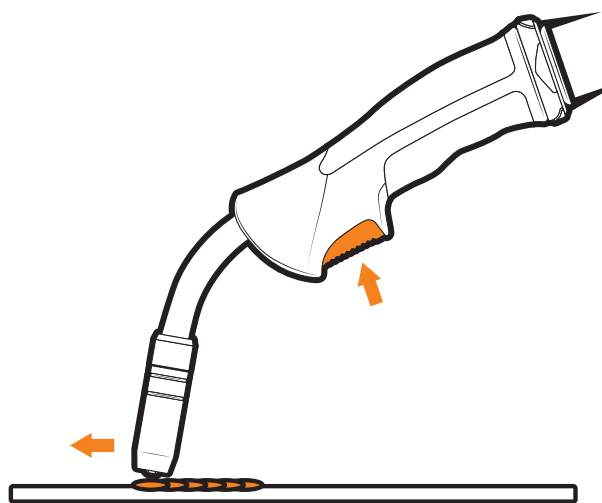

24 **For 1kg spool:** After removing spool holder nut, unscrew the 1kg spool bolt located inside the spool holder housing.

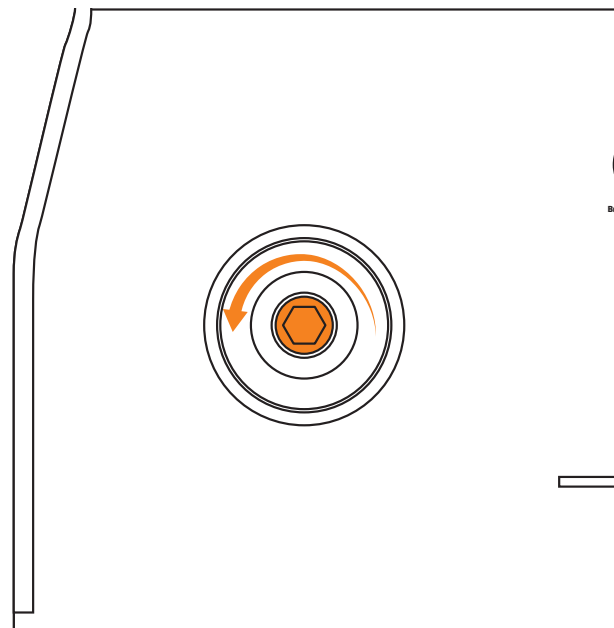

SETUP FOR MIG (GAS-SHIELDED)

25 For 1kg spool: Remove spool holder housing and spring. Place 1kg spool housing inside the square hole where the spool housing is removed from. The 1kg housing is found on the inside of the main spool holder housing.

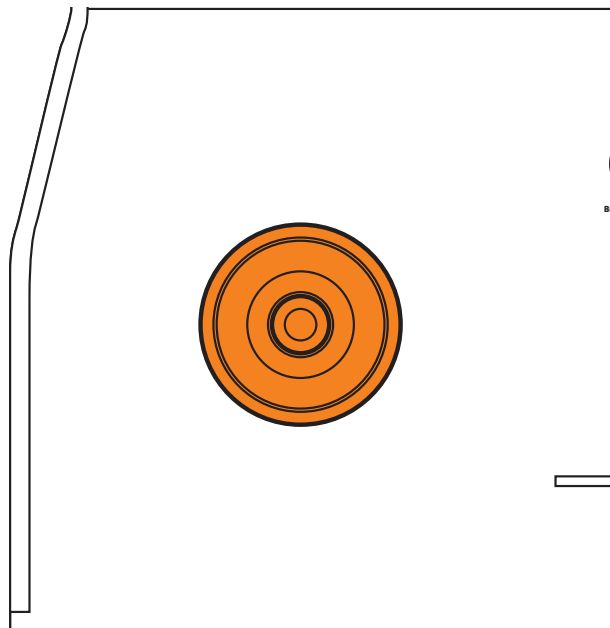

26 For 1kg spool: Place 1kg spool over 1kg spool housing, then tighten and secure with 1kg spool bolt and nut.

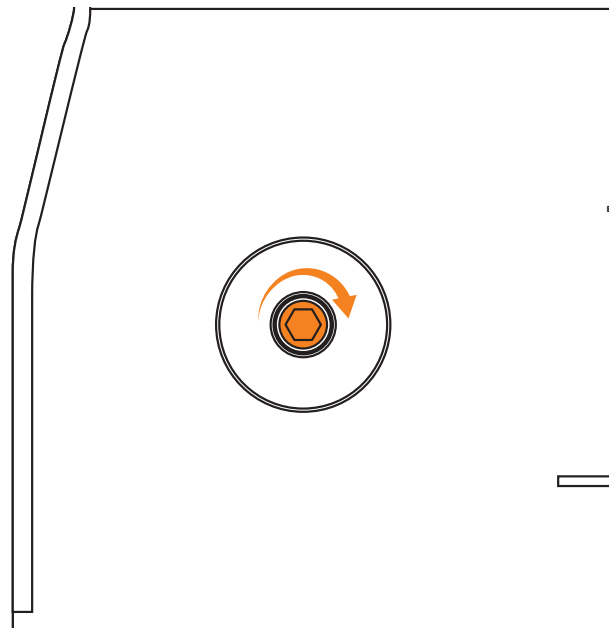

MIG (Metal Inert Gas) Welding

MIG (Metal Inert Gas) welding, also known as GMAW (Gas Metal Arc Welding) or MAG (Metal Active Gas Welding), is a semi-automatic arc welding process in which a consumable wire electrode and a shielding gas are fed through a welding gun. A constant voltage, direct current power source is most commonly used with MIG welding.

There are four primary methods of metal transfer in MIG welding. Short circuit (also known as dip transfer), globular transfer, spray transfer and pulse spray, each of which has distinct properties and corresponding advantages and limitations. To perform MIG welding, the necessary equipment is a welding gun, a wire feed unit, a welding power supply, an electrode wire, and a shielding gas supply.

Short Circuit Transfer

Short circuit transfer is the most commonly used method whereby the wire electrode is fed continuously down the welding torch through to and exiting the contact tip. The wire touches the workpiece and causes a short circuit the wire heats up and begins to form a molten bead, the bead separates from the end of the wire and forms a droplet that is transferred into the weld pool. This process is repeated about 100 times per second, making the arc appear constant to the human eye.

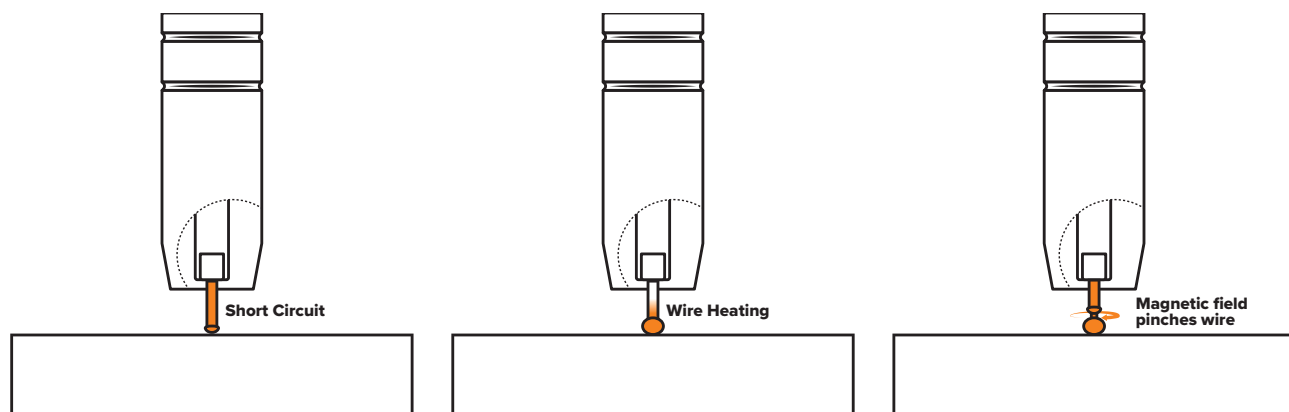

The wire approaches the workpiece and touches the work, creating a short circuit between the wire and the base metal, because there is no space between the wire and the base metal there is no arc and current flows through the wire.

The wire cannot support all the current flow, resistance builds up and the wire becomes hot and weak and begins to melt.

The current flow creates a magnetic field that begins to pinch the melting wire forming it into droplet.

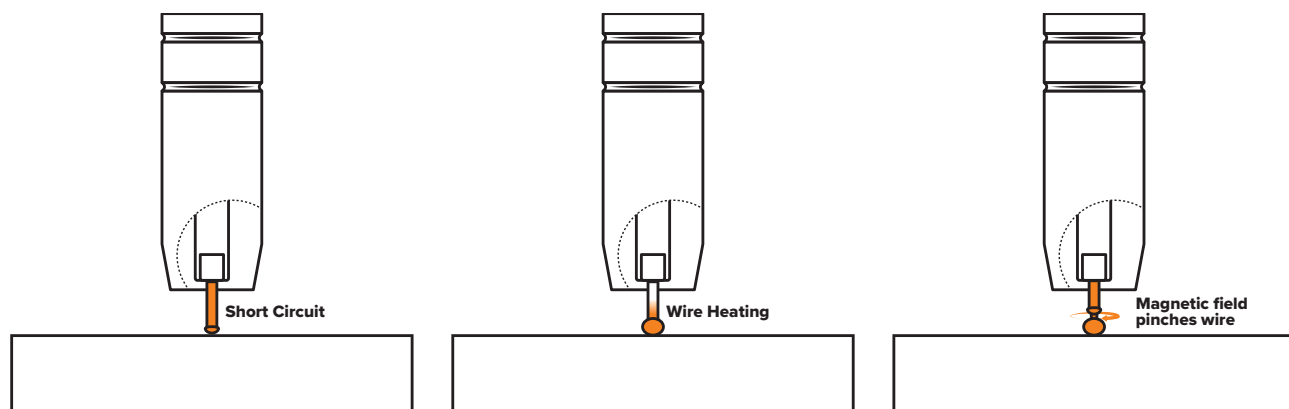

The pinch causes the forming droplet to separate and fall towards the forming weld pool.

An arc is created at the separation of the droplet and the heat and force of the arc flattens out the droplet into the weld pool. The heat of the arc melts the end of the wire slightly as it feeds towards the base metal.

The wire feed speed overcomes the heat of the arc and the wire again approaches the work to short circuit and repeat the cycle.

MIG WELDING GUIDE

Basic MIG Welding

Good weld quality and weld profile depend on gun angle, the direction of travel, electrode extension (stick out), travel speed, the thickness of base metal, wire feed speed (amperage) and arc voltage. To follow are some basic guides to assist with your setup.

Gun Position - Travel Direction & Work Angle

Gun position or technique usually refers to how the wire is directed at the base metal, the angle and travel direction chosen. Travel speed and work angle will determine the characteristic of the weld bead profile and degree of weld penetration.

Push Technique

The wire is located at the leading edge of the weld pool and pushed towards the un-melted work surface. This technique offers a better view of the weld joint and direction of the wire into the weld joint. Push technique directs the heat away from the weld puddle, allowing faster travel speeds providing a flatter weld profile with light penetration - useful for welding thin materials. The welds are wider and flatter, allowing for minimal clean up / grinding time.

Perpendicular Technique

The wire is fed directly into the weld. This technique is used primarily for automated situations or when conditions make it necessary. The weld profile is generally higher, and deeper penetration is achieved.

Pull/Drag Technique

The gun and wire are dragged away from the weld bead. The arc and heat are concentrated on the weld pool. The base metal receives more heat, deeper melting, more penetration and the weld profile is higher with more buildup.

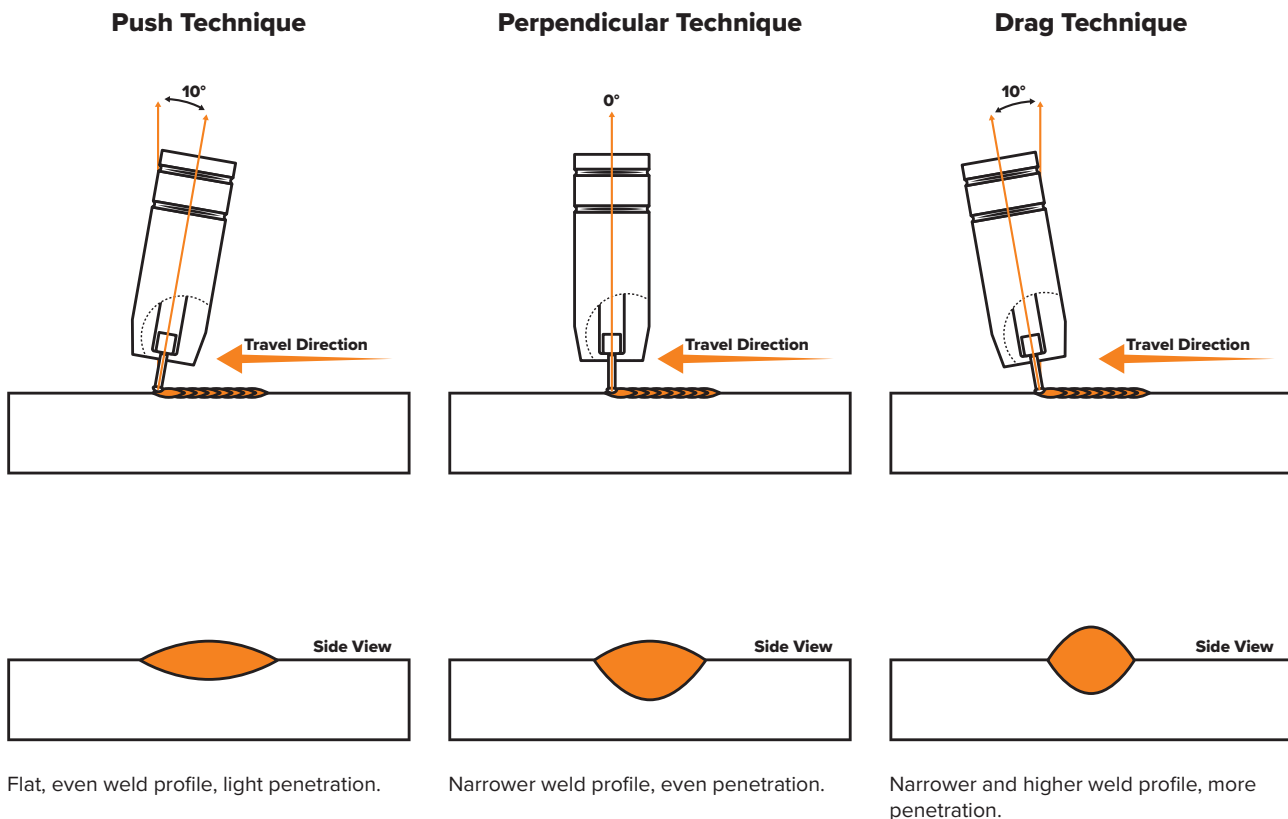

Travel Angle

The travel angle is the right to left, relative to the direction of welding. A travel angle of 5°- 15° is ideal and produces the right level of control over the weld pool. A travel angle higher than 20° will give an unstable arc condition with poor weld metal transfer, less penetration, high levels of spatter, weak gas shielding and a poor quality finished weld.

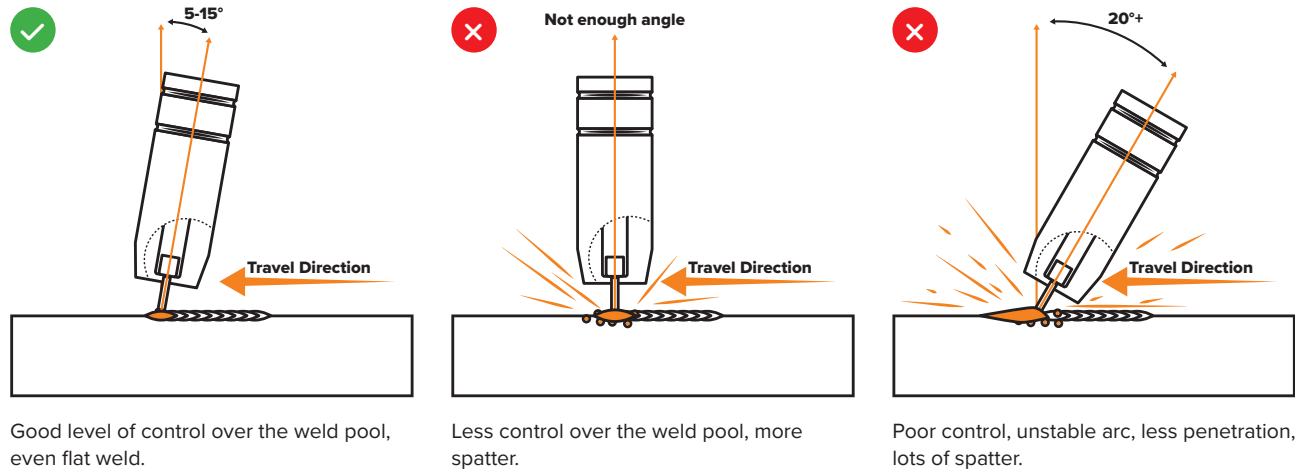

Work Angle

The work angle is the up and down angle of the gun relative to the workpiece.

The correct work angle provides good bead shape, prevents undercut, uneven penetration, weak gas shielding and a poor quality finished weld.

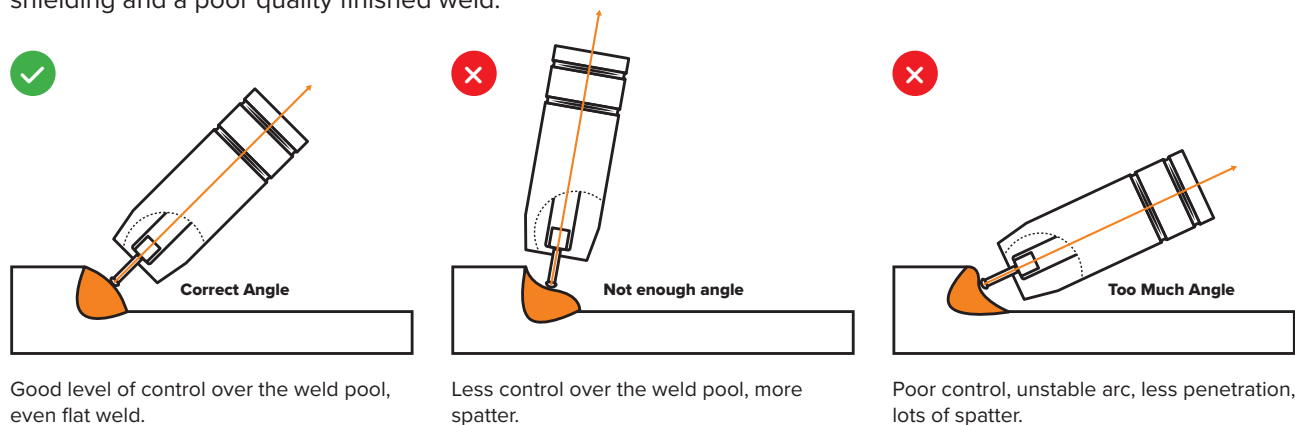

Stick Out

Stick out is the length of the unmelted wire protruding from the end of the contact tip.

A constant, even stick out of 5-10mm will produce a stable arc and an even current flow providing good penetration and even fusion. Too short a stick out will cause an unstable weld pool, produce spatter and overheat the contact tip. Too long stick out will cause an unstable arc, lack of penetration, lack of fusion, and increase spatter.

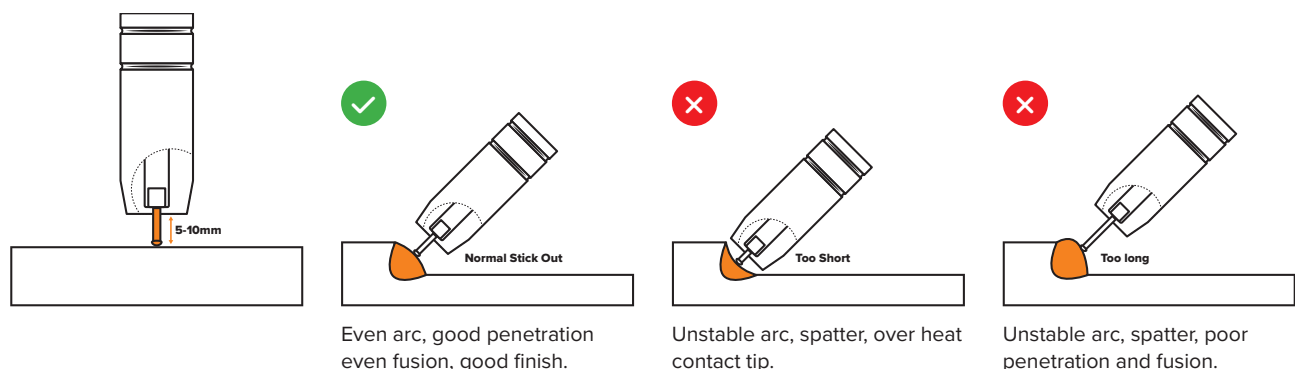

Travel Speed

Travel speed is the rate that the gun is moved along the weld joint and is usually measured in mm per minute. Travel speeds can vary depending on conditions and the welder's skill and is limited to the welder's ability to control the weld pool. The push technique allows faster travel speeds than the drag technique.

The gas flow must also correspond with the travel speed, increasing with faster travel speed and decreasing at a slower speed. Travel speed needs to match the amperage and will decrease as the material thickness and amperage increase.

Travel Speed Too Fast

Too fast a travel speed produces too little heat per mm of travel resulting in less penetration and reduced weld fusion. The weld bead solidifies very quickly, trapping gases inside the weld metal and causing porosity. Undercutting of the base metal can also occur, and an unfilled groove in the base metal is created when the travel speed is too fast to allow molten metal to flow into the weld crater created by the arc heat.

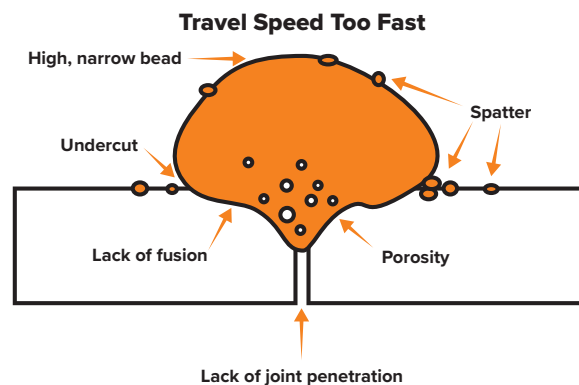

Travel Speed Too Slow

Too slow a travel speed produces a large weld with a lack of penetration and fusion. The energy from the arc dwells on top of the weld pool rather than penetrating the base metal. This produces a wider weld bead with more deposited weld metal per mm than is required, resulting in a weld deposit of poor quality.

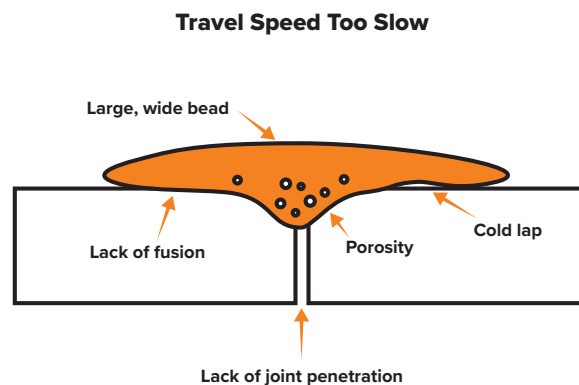

Correct Travel Speed

The correct travel speed keeps the arc at the leading edge of the weld pool, allowing the base metal to melt sufficiently to create good penetration, fusion and wetting out of the weld pool producing a weld deposit of good quality.

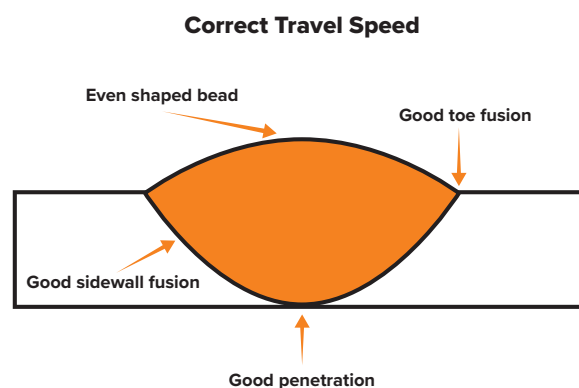

Wire Types and Sizes

Use the correct wire type for the base metal being welded. Use stainless steel wire for stainless steel, aluminium wires for aluminium and steel wires for steel.

Using poor quality milled wire can result in poor performance and appearance. To ensure optimal performance when welding, use standards approved wire such as UNIMIG HYPERMIG wire.

Use a smaller diameter wire for thin base metals. For thicker materials use a larger wire diameter and larger machine. Check the recommended welding capability of your machine.

As a guide, refer to the "Welding Wire Thickness Chart" below.

Material Type	Wire Type	Wire Size	Drive Roller	Polarity	Shielding Gas	Gas Flow Rate	Material Thickness	1mm	2mm	3mm	4mm	6mm	8mm	10mm
								Voltage (V)	Wire Speed (m/min)	Voltage (V)	Wire Speed (m/min)	Voltage (V)	Wire Speed (m/min)	Voltage (V)
Steel	ER70S-6	0.8mm	V Groove	DCEP+	ArCO ₂	8-12L/min	Voltage (V)	17.5	19.7	24.5	25.5	26.5	28.5	
							Wire Speed (m/min)	8.5	10	14.5	15.5	16.5	18	
	ER70S-6	0.9mm	V Groove	DCEP+	ArCO ₂	8-12L/min	Voltage (V)		21	25	26	26.7	29	31
							Wire Speed (m/min)		12.4	15	16	16.4	16.9	17.6
	E71T-11	0.8mm	F Groove (Knurled)	DCEN-			Voltage (V)	13.2	14.2	15.5	17.3	19.3	21.4	
							Wire Speed (m/min)	1.8	2	3.4	4.8	6.6	8.3	
	E71T-11	0.9mm	F Groove (Knurled)	DCEN-			Voltage (V)		15	15.3	17.6	18	22	26
							Wire Speed (m/min)		2.5	3.5	4.9	5.8	9	11.5
Stainless Steel	316LSi	0.8mm	V Groove	DCEP+	ArCO ₂	8-12L/min	Voltage (V)	17.5	19.7	24.5	25.5	26.5	28.5	
							Wire Speed (m/min)	8.5	10	14.5	15.5	16.5	18	
	316LSi	0.9mm	V Groove	DCEP+	ArCO ₂	8-12L/min	Voltage (V)		21	25	26	26.7	29	31
							Wire Speed (m/min)		12.4	15	16	16.4	16.9	17.6
Aluminium	5356	1.0mm	U Groove	DCEP+	Ar	8-12L/min	Voltage (V)		11	12	13	17	18	
							Wire Speed (m/min)		9	10	11	14	16	

Gas Selection

The purpose of the gas in the MIG process is to shield the wire, the arc and the molten weld metal from the atmosphere. Most metals when heated to a molten state will react with the air in the atmosphere, without the protection of the shielding gas the weld produced would contain defects like porosity, lack of fusion and slag inclusions. Additionally, some of the gas becomes ionised (electrically charged) and helps the current flow smoothly.

- The correct gas flow is critical in protecting the welding zone from the atmosphere.
- Too low a flow will give inadequate coverage and result in weld defects and unstable arc conditions.
- Too high a flow can cause air to be drawn into the gas column and contaminate the weld zone.

Use the correct shielding gas. CO₂ is suitable for steel and offers good penetration characteristics; the weld profile is narrower and slightly more raised than the weld profile obtained from Argon CO₂ mixed gas. Argon CO₂ mix gas offers better weldability for thin metals and has a wider range of setting tolerance on the machine. Argon 80% / CO₂ 20% is a good all-round mix suitable for most applications.

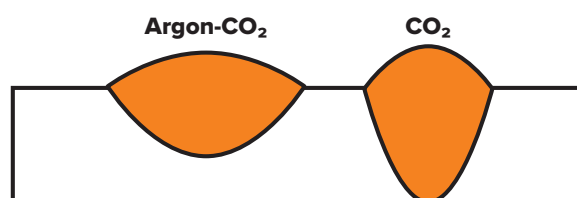

MIG DRIVE ROLLERS

Drive Roller Selection

The importance of smooth, consistent wire feeding during MIG welding cannot be emphasised enough. The smoother the wire feed, the better the welding will be. Feed rollers or drive rollers are used to feed the wire mechanically along the length of the welding gun.

Feed rollers are designed to be used for certain types of welding wire, and they have different types of grooves machined in them to accommodate the different types of wire. The wire is held in the groove by the top roller of the wire drive unit and is referred to as the pressure roller. Pressure is applied by a tension arm that can be adjusted to increase or decrease the pressure as required. The type of wire will determine how much pressure can be applied and what type of drive roller is best suited to obtain optimum wire feed.

Solid Hard Wire (V Groove)

Steel or stainless steel require a drive roller with a **V** shape groove for optimum grip and drive capability. Solid wires can have more tension applied to the wire from the top pressure roller that holds the wire in the groove, and the V shape groove is more suited for this. Solid wires are more forgiving to feed due to their higher cross-sectional column strength. They are stiffer and don't bend so easily.

Aluminium (U Groove)

Aluminium requires a **U** shape groove. Aluminium wire has a lot less column strength, can bend easily and is, therefore, more difficult to feed. Soft wires can easily buckle at the wire feeder where the wire is fed into inlet guide tube of the torch. The U-shaped roller offers more surface area grip and traction to help feed the softer wire. Softer wires also require less tension from the top pressure roller to avoid deforming the shape of the wire, too much tension will push the wire out of shape and cause it to catch in the contact tip.

Flux Cored / Gasless Wire (Knurled/F Groove)

These wires are made up of a thin metal sheath that has fluxing, and metal compounds layered onto it and then rolled into a cylinder to form the finished wire. The wire cannot take too much pressure from the top roller as it can be crushed and deformed if too much pressure is applied. A **Knurled/F** groove drive roller has been developed, and it has small serrations in the groove. The serrations grip the wire and assist in driving it without too much pressure from the top roller. The downside to the knurled wire feed roller on flux-cored wire is it will slowly over time bit by bit eat away at the surface of the welding wire, and these small pieces will eventually go down into the liner. This will cause clogging in the liner and added friction that will lead to welding wire feed problems. A U groove wire can also be used for flux core wire without the wire particles coming off the wire surface. However, it is considered that the knurled roller will give a more positive feed of flux core wire without any deformation of the wire shape.

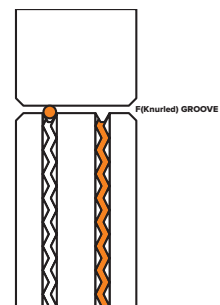
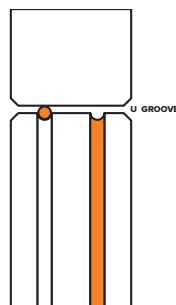
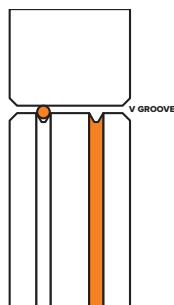

Roller Diameter: 30/22

V Groove Roller (Steel Wire)

SKU	Description
0.6-0.8V30/22	Drive Roll V Groove 0.6-0.8mm
0.8-1.0V30/22	Drive Roll V Groove 0.8-1.0mm
0.9-1.2V30/22	Drive Roll V Groove 0.9-1.2mm
1.0-1.2V30/22	Drive Roll V Groove 1.0-1.2mm

U Groove Roller (Aluminium Wire)

SKU	Description
0.8-1.0U30/22	Drive Roll U Groove 0.8-1.0mm
0.9-1.0U30/22	Drive Roll U Groove 0.9-1.0mm
0.9-1.2U30/22	Drive Roll U Groove 0.9-1.2mm
1.0-1.2U30/22	Drive Roll U Groove 1.0-1.2mm

Knurled/F Groove (Flux-Cored Wire)

SKU	Description
0.8-0.9F30/22	Drive Roll Knurled 0.8-0.9mm
0.9-1.2F30/22	Drive Roll Knurled 0.9-1.2mm

CHANGING THE MIG TORCH LINER

1 Remove MIG torch front end parts.

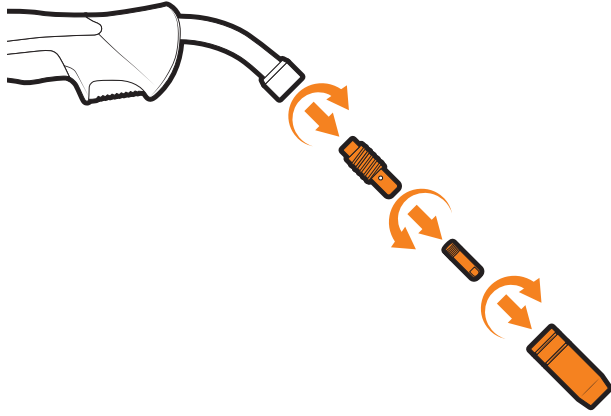

2 Remove the liner retaining nut.

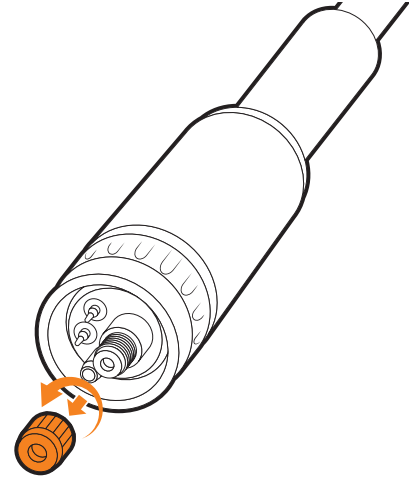

3 Carefully pull out and completely remove the existing liner. Ensure MIG torch is completely unravelled until setup is complete.

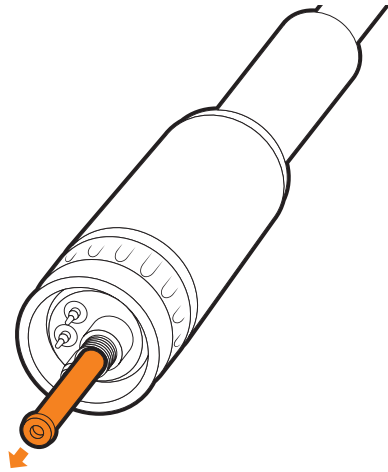

4 Carefully feed in the new liner down the torch lead all the way to exit the torch neck.

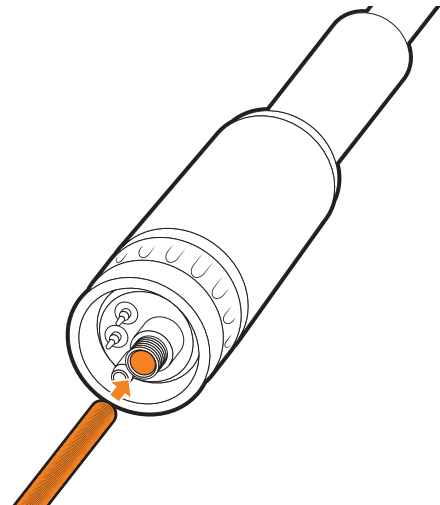

CHANGING THE MIG TORCH LINER

- 5 Fit the liner retaining nut and screw only 1/2 way down.



- 6 Snip the excess liner off, about the length of the where tip holder sits past the end of the torch neck.

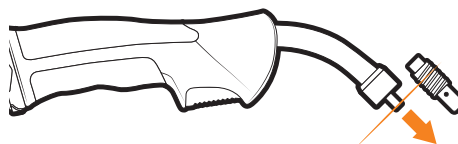

- 7 Replace the front end parts

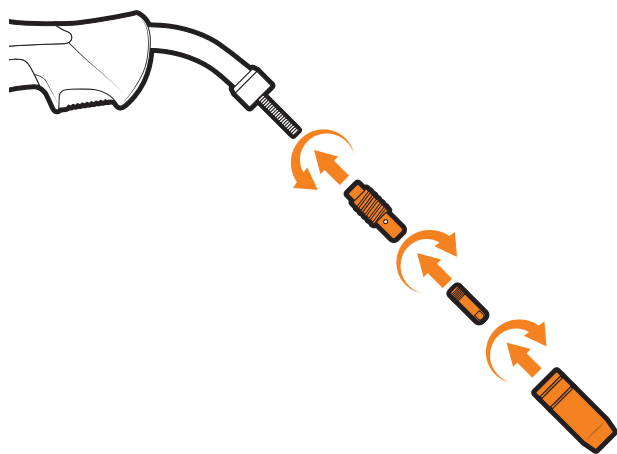

- 8 Fully screw down the liner retaining nut and nip it up tight. This compresses the liner inside the torch cable assembly preventing it moving during use and ensures good wire feed.



CHANGING THE MIG TORCH LINER (ALUMINIUM)

1 Remove MIG torch front end parts.

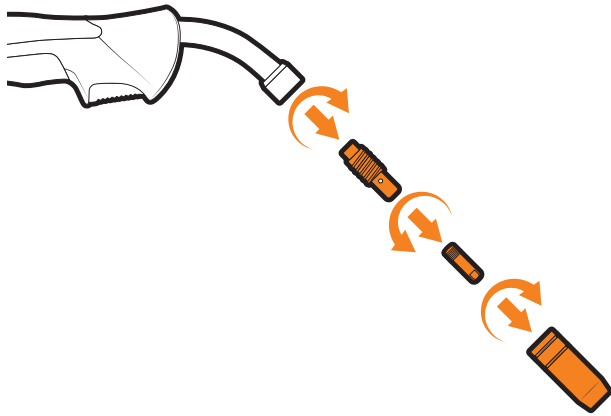

2 Remove the liner retaining nut.

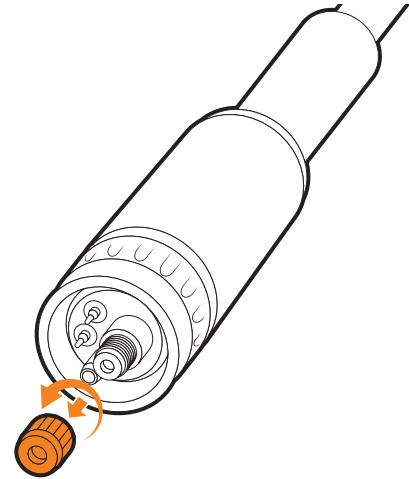

3 Carefully pull out and completely remove the existing liner. Ensure MIG torch is completely unravelled until setup is complete.

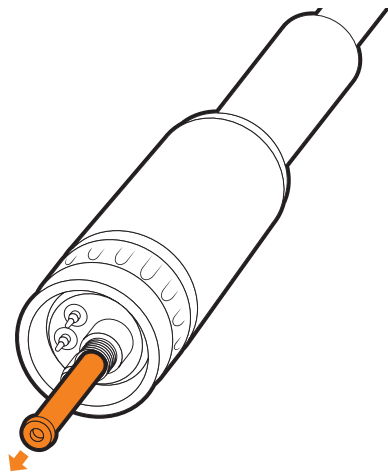

4 Fit the neck spring to the front end of the aluminium liner.

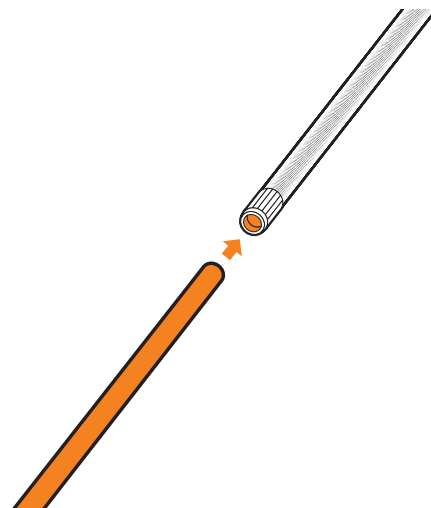

CHANGING THE MIG TORCH LINER (ALUMINIUM)

5 Feed liner and neck spring through the torch, then fit liner collet, liner O-ring and liner retaining nut.

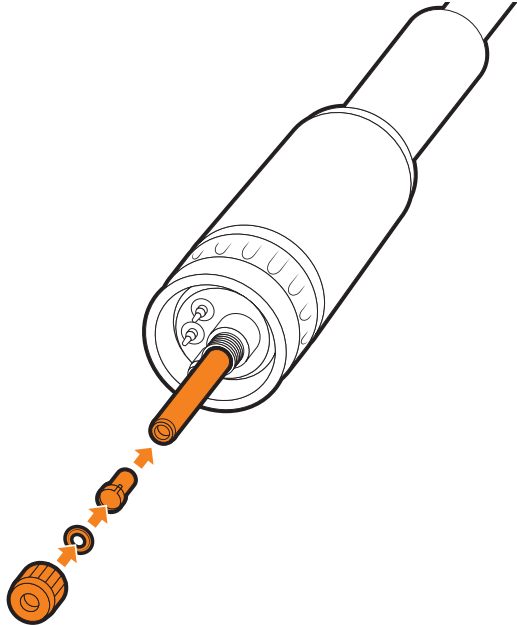

6 Push the liner firmly into the torch lead and tighten the liner retaining nut.



7 Loosen the inlet guide tube retaining screw.

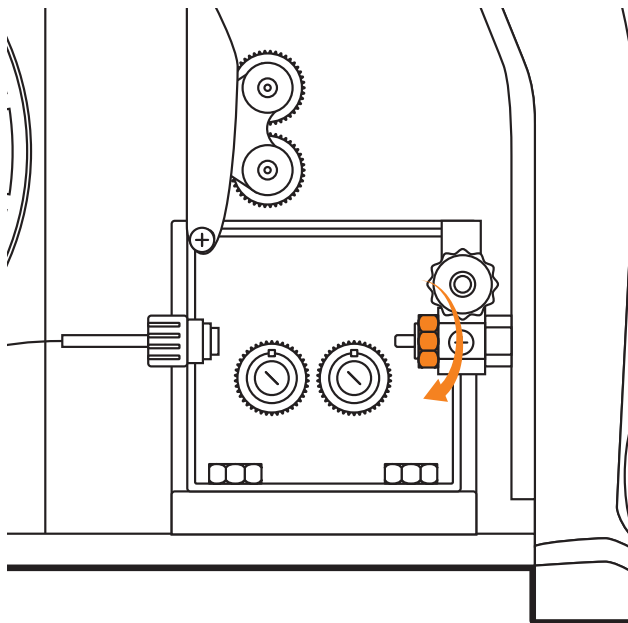

8 Remove the inlet guide tube using long nose pliers.

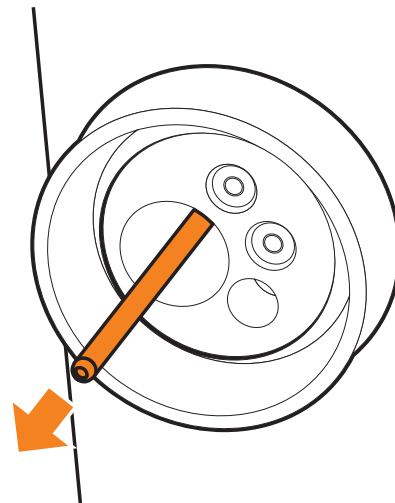

CHANGING THE MIG TORCH LINER (ALUMINIUM)

- 9 Install a U groove drive roller of the correct size for the diameter wire being used.

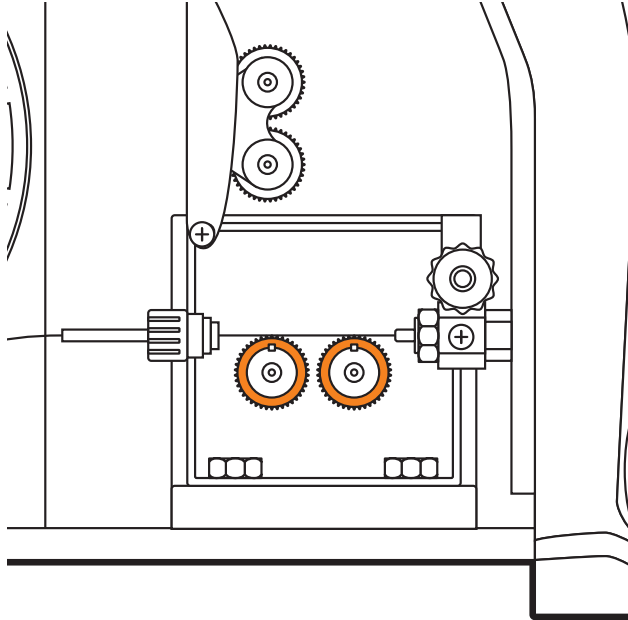

- 10 Feed liner through Euro connection, and connect and tighten the torch.

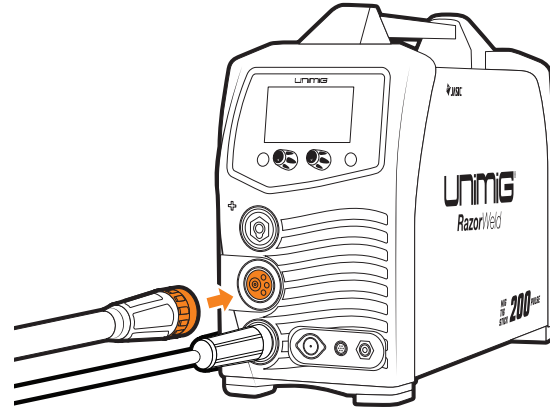

- 11 Take the extended aluminium liner all the way up and over the drive roller.

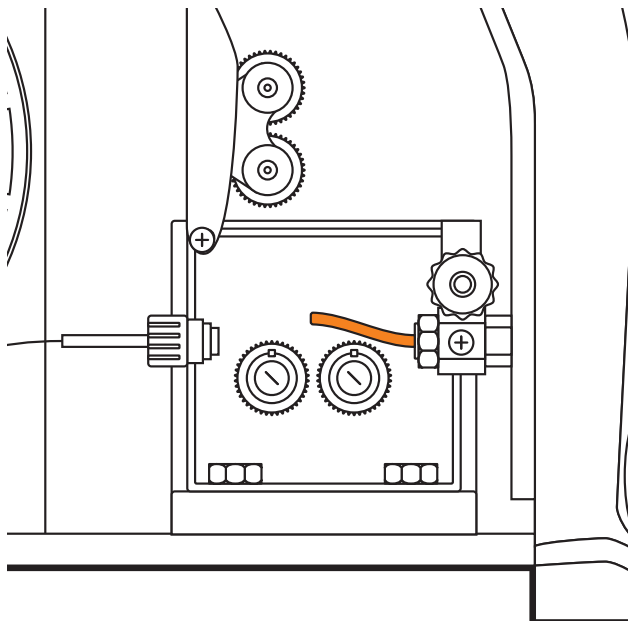

- 12 Cut the extended aluminium liner with a sharp knife just in front of the drive roller.

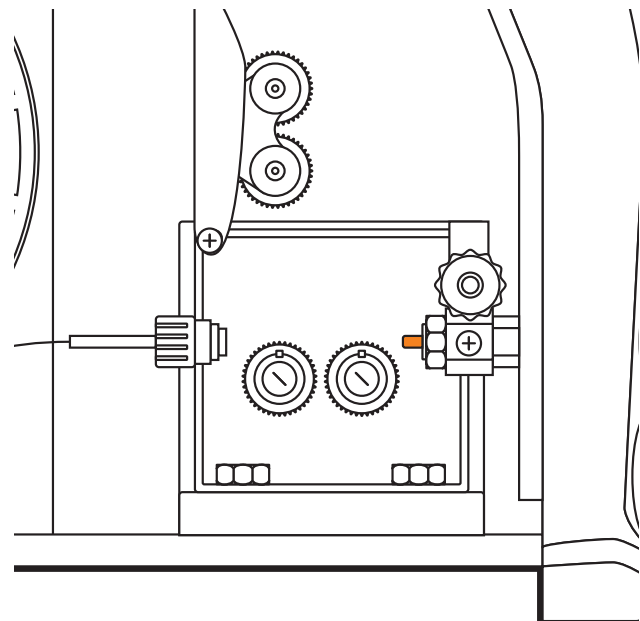

CHANGING THE MIG TORCH LINER (ALUMINIUM)

- 13 Replace the front end parts.

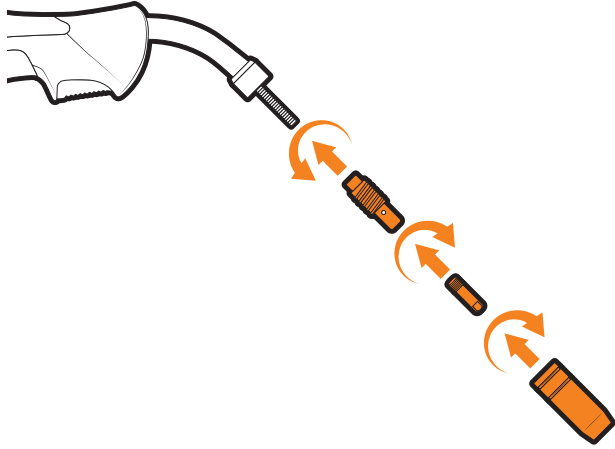

SETUP FOR MMA (STICK) WELDING

- 1 For DC+ electrodes, connect earth clamp to the **negative (-)** dinse connection, and electrode holder to the **positive (+)** dinse connection.

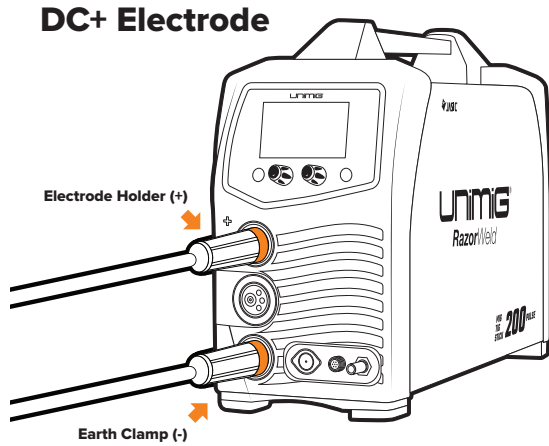

- 2 For DC- electrodes, connect earth clamp to the **positive (+)** dinse connection, and electrode holder to the **negative (-)** dinse connection.

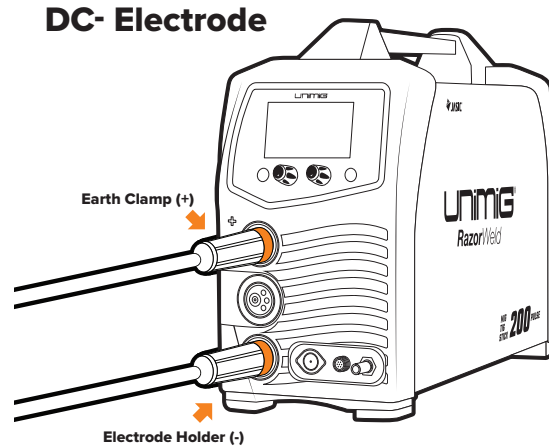

- 3 Connect the plug into a 15 AMP socket, then switch the machine ON.

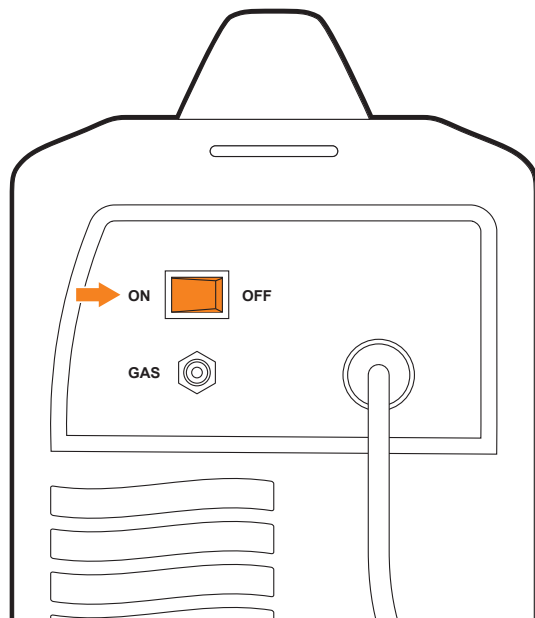

- 4 Set weld parameters on the digital screen. See "Digital Screen - STICK" on page 18.

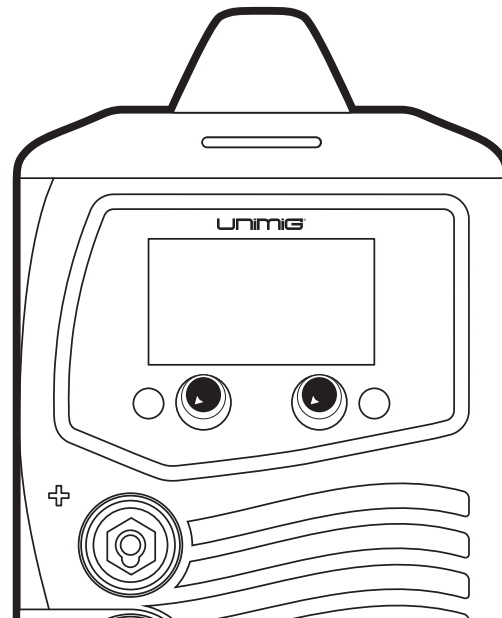

SETUP FOR MMA (STICK) WELDING

5 Twist electrode holder to loosen grip.

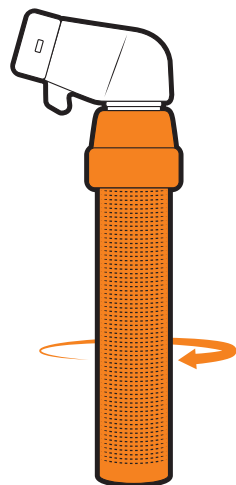

6 Place electrode into electrode holder.

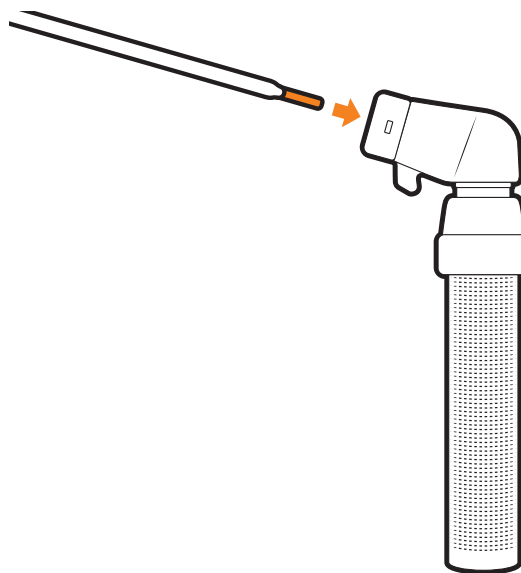

7 Twist electrode holder to tighten and securely grip electrode.

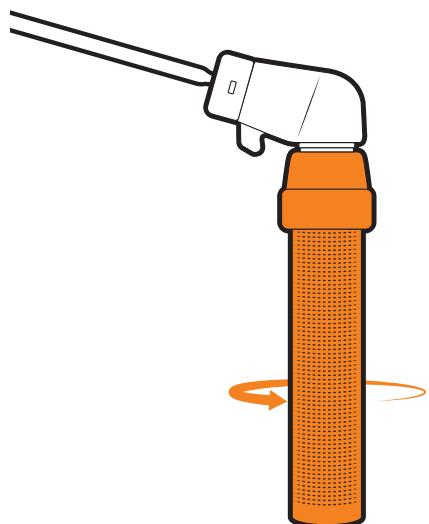

8 Connect earth clamp to your workpiece.

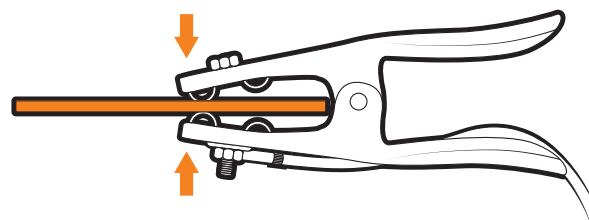

SETUP FOR MMA (STICK) WELDING

- 9 Strike electrode against workpiece to initiate arc.

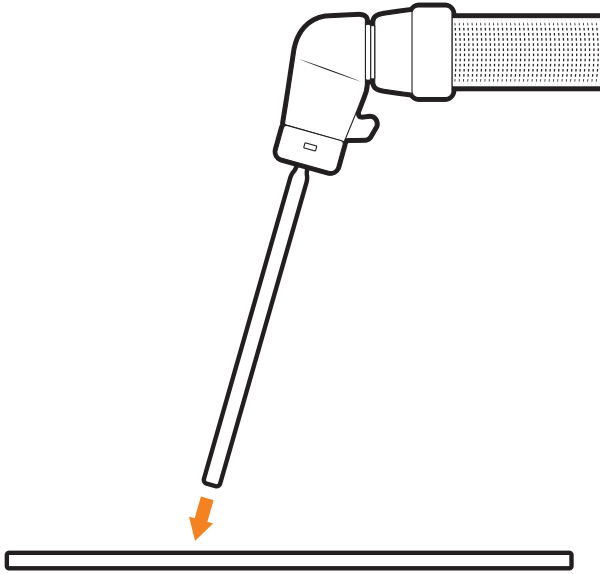

- 10 Drag along workpiece to weld. Pull the electrode away from the workpiece to finish weld.

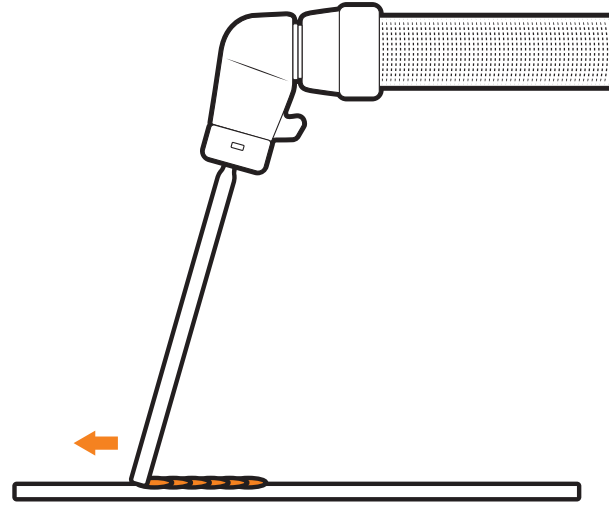

MMA (STICK) WELDING GUIDE

Manual Metal Arc (STICK) Welding

One of the most common types of arc welding is Manual Metal Arc welding, also known as MMA welding. An electric current is used to strike an arc between the base material and a consumable electrode rod or 'stick'. The electrode rod is made of a material that is compatible with the base material being welded. They are covered with a flux that gives off gaseous vapours that serve as a shielding gas and provide a layer of slag, both of which protect the weld area from atmospheric contamination. The electrode core itself acts as filler material. The residue from the flux that forms a slag covering over the weld metal must be chipped away after welding.

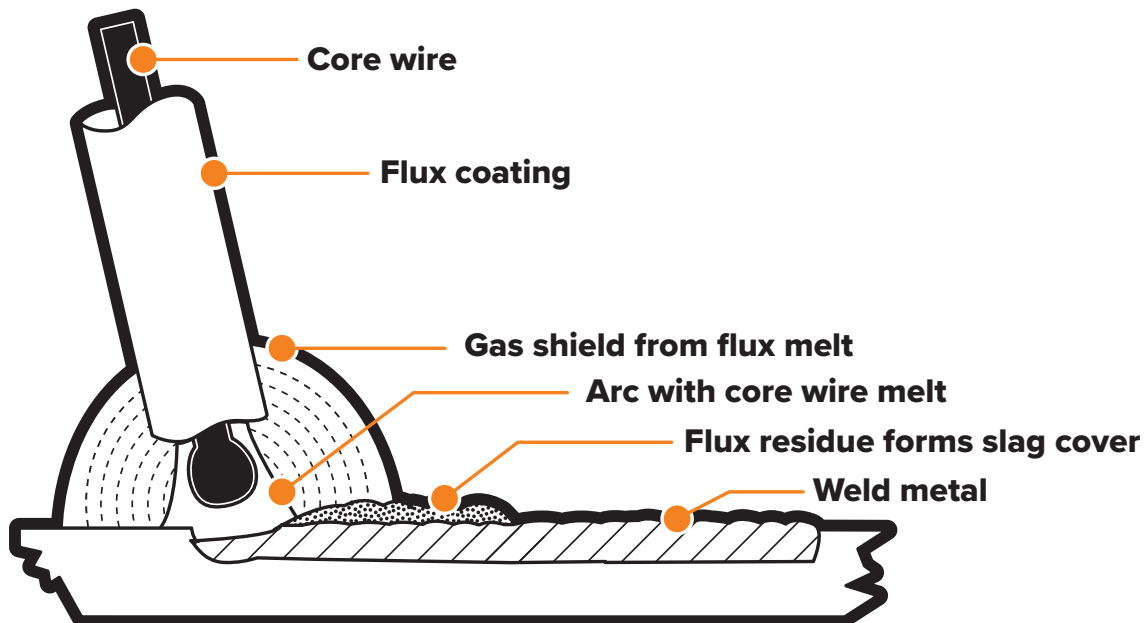

- The arc is initiated by momentarily touching the electrode to the base metal.
- The heat of the arc melts the surface of the base metal to form a molten pool at the end of the electrode.
- The melted electrode metal is transferred across the arc into the molten pool and becomes the deposited weld metal.
- The deposit is covered and protected by a slag which comes from the electrode coating.
- The arc and the immediate area are enveloped by an atmosphere of protective gas.

Manual Metal Arc (stick) electrodes have a solid metal wire core and a flux coating. These electrodes are identified by the wire diameter and by a series of letters and numbers. The letters and numbers identify the metal alloy and the intended use of the electrode.

The metal wire core works as a conductor of the current that maintains the arc. The core wire melts and is deposited into the welding pool.

The covering on a shielded metal arc welding electrode is called flux. The flux on the electrode performs many different functions.

These include:

- Producing a protective gas around the weld area
- Providing fluxing elements and de-oxidisers
- Creating a protective slag coating over the weld as it cools
- Establishing arc characteristics
- Adding alloying elements.

Covered electrodes serve many purposes in addition to adding filler metal to the molten pool. These additional functions are provided mainly by the covering on the electrode.

Electrode Selection

As a general rule, the selection of an electrode is straight forward, in that it is only a matter of selecting an electrode of similar composition to the parent metal. However, for some metals, there is a choice of several electrodes, each of which has particular properties to suit specific classes of work.

The size of the electrode generally depends on the thickness of the section being welded, and the thicker the section, the larger the electrode required. The table gives the maximum size of electrodes that may be used for various thicknesses of section based on using a general-purpose type 6013 electrode.

Average Thickness of Material	Maximum Recommended Electrode Diameter
3-6mm	2.6mm
6-12mm	3.2mm
12-20mm	4.0mm
20mm+	5.0mm

Correct current selection for a particular job is an important factor in arc welding. With the current set too low, it is difficult to strike and maintain a stable arc. The penetration is reduced and beads with a distinct rounded profile will be deposited. Too high a current is accompanied by overheating of the electrode, resulting in undercut, burning through of the base metal and producing excessive spatter. Normal current for a particular job may be considered as the maximum, which can be used without burning through the work, over-heating the electrode or producing a rough spattered surface. The table shows current ranges generally recommended for a general-purpose type 6013 electrode.

Electrode Size (ø mm)	Current Range (Amps)
2.6mm	60 - 100
3.2mm	100 - 130
4.0mm	130 - 165
5.0mm	165 - 260

Arc Length

To strike the arc, the electrode should be gently scraped on the work until the arc is established. An arc too long reduces penetration, produces spatter and gives a rough surface finish to the weld. An excessively short arc will cause sticking of the electrode and result in poor quality welds. The general rule of thumb for down hand welding is to have an arc length no greater than the diameter of the core wire.

Electrode Angle

The angle that the electrode makes with the work is important to ensure a smooth, even transfer of metal. When welding in down hand, fillet, horizontal or overhead, the angle of the electrode is generally between 5 and 15 degrees towards the direction of travel. When vertical up welding, the angle of the electrode should be between 80 and 90 degrees to the workpiece.

Travel Speed

The electrode should be moved along in the direction of the joint being welded at a speed that will give the size of run required. At the same time, the electrode is fed downwards to keep the correct arc length at all times. Excessive travel speeds lead to poor fusion, lack of penetration, etc., while too slow a rate of travel will frequently lead to arc instability, slag inclusions and poor mechanical properties.

Material and Joint Preparation

The material to be welded should be clean and free of any moisture, paint, oil, grease, mill scale, rust or any other material that will hinder the arc and contaminate the weld material. Joint preparation will depend on the method used include sawing, punching, shearing, machining, flame cutting and others. In all cases, edges should be clean and free of any contaminates. The chosen application will determine the type of joint.

SETUP FOR TIG

- 1 Connect the TIG torch to the **negative (-)** dinse connection, twist to lock in place. Plug 2-pin torch connector in the 2-pin outlet. Connect the gas connector to the gas outlet.

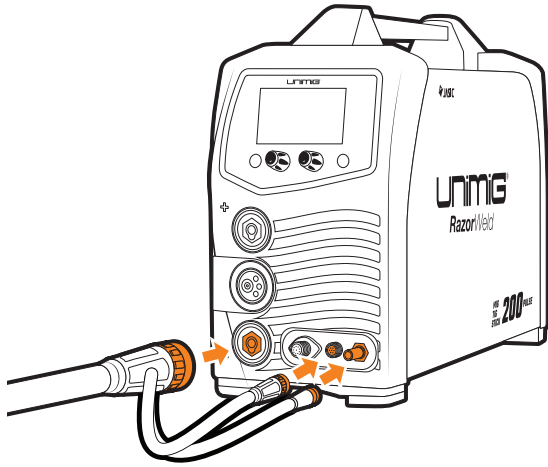

- 2 Connect the earth clamp to the **positive (+)** dinse connection, twist to lock in place.

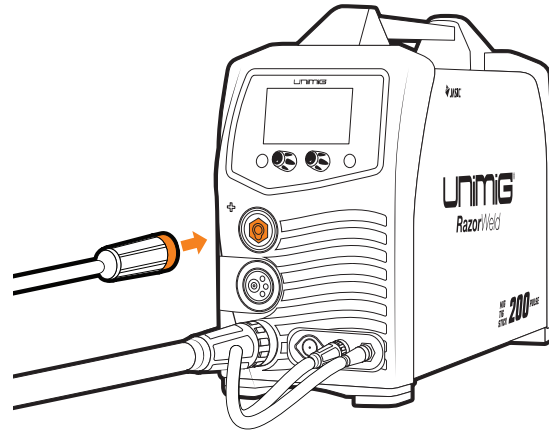

- 3 Connect the plug into a 15 AMP socket, then switch the machine ON.

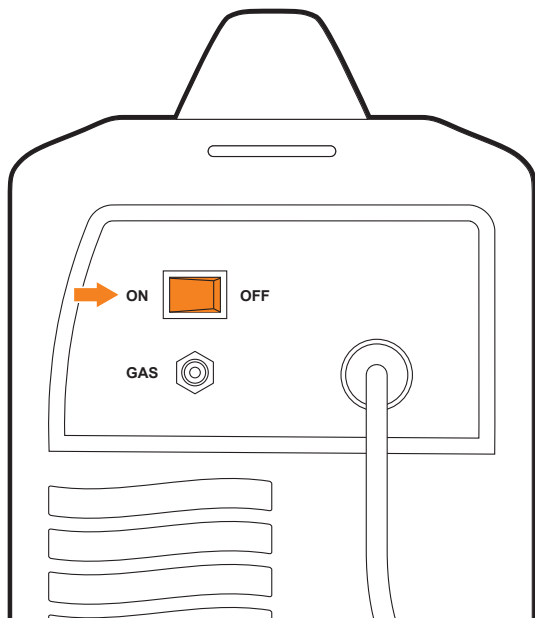

- 4 Connect gas hose to the gas inlet on the rear of the machine.

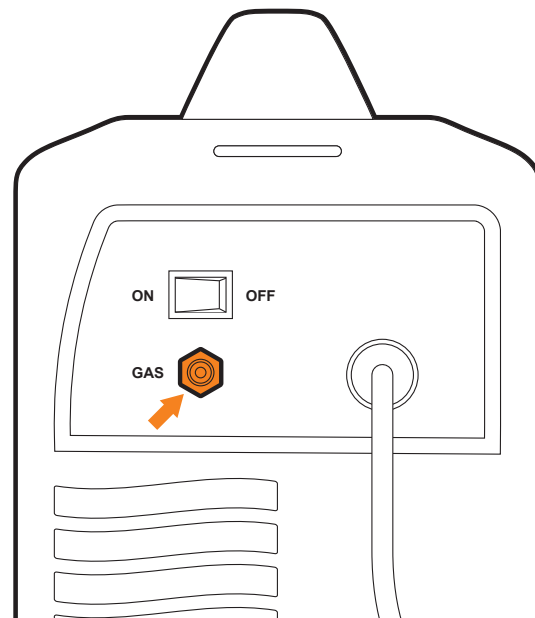

SETUP FOR TIG

5 Place argon flowmeter regulator into your gas outlet.

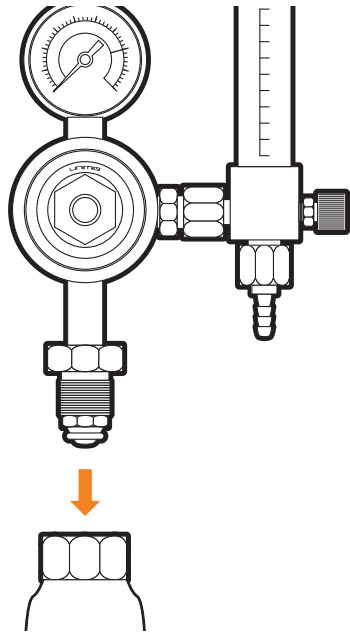

6 Tighten securely with wrench.

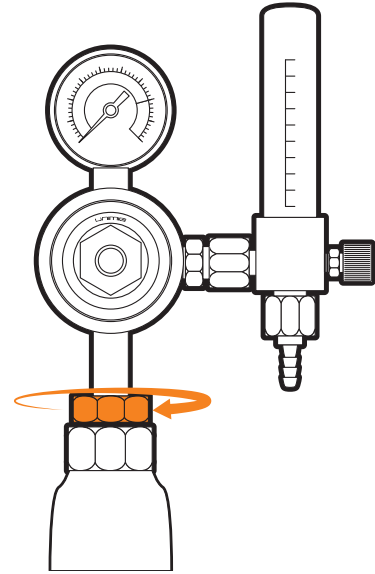

7 Connect gas hose to the flowmeter outlet, and crimp in place.

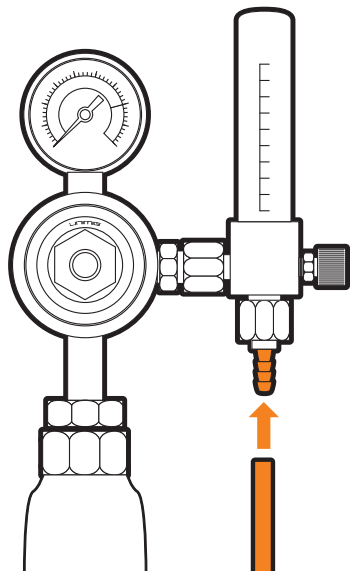

8 Adjust gas flow to 6-10L/min.

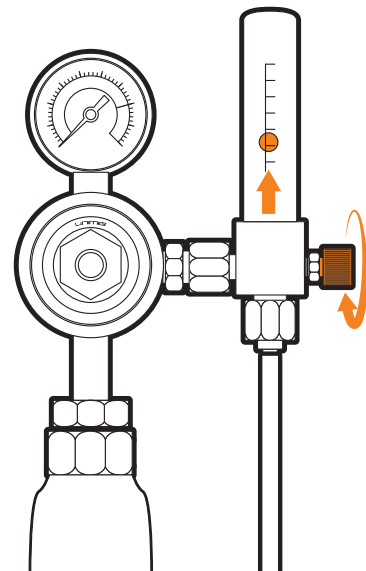

SETUP FOR TIG

9 Set weld parameters on the digital screen. See "Digital Screen - TIG" on page 16.

10 Connect earth clamp to your workpiece.

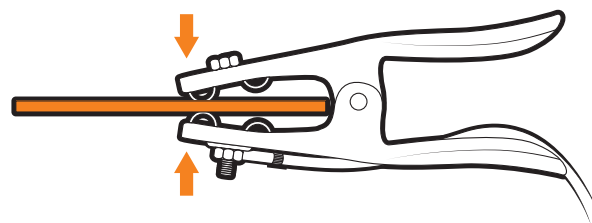
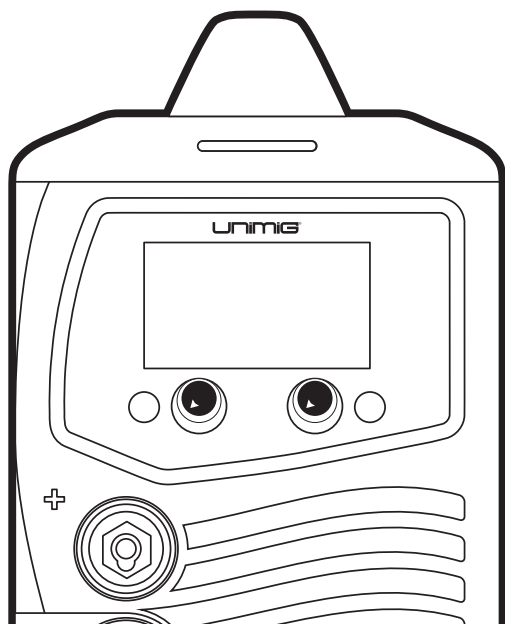

11 Initiate arc by pressing the button on the TIG Torch.

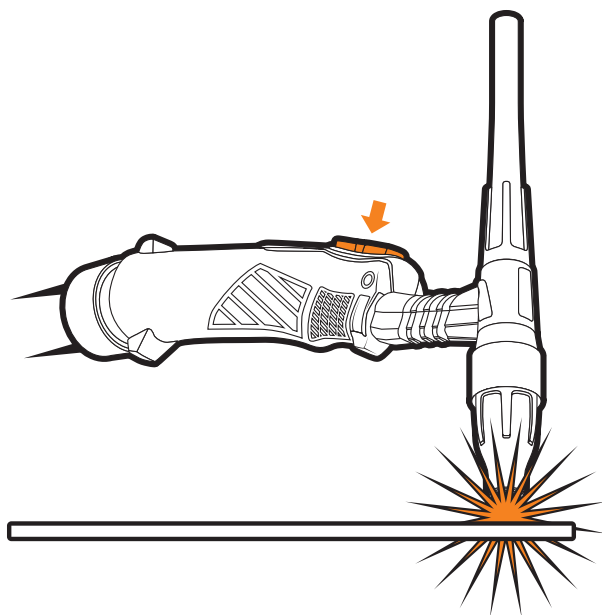

IMPORTANT! - We strongly recommend that you check for gas leakage prior to operation of your machine. We recommend that you close the cylinder valve when the machine is not in use.

Welding Guns Of Australia PTY LTD, authorised representatives or agents of Welding Guns Of Australia PTY LTD will not be liable or responsible for the loss of any gas.

DC TIG Welding

The DC power source uses what is known as DC (direct current) in which the main electrical component known as electrons flow in only one direction from the negative pole (terminal) to the positive pole (terminal). In the DC electrical circuit, there is an electrical principle at work which should always be taken into account when using any DC circuit. With a DC circuit, 70% of the energy (heat) is always on the positive side. This needs to be understood because it determines what terminal the TIG torch will be connected to (this rule applies to all the other forms of DC welding as well).

DC TIG welding is a process in which an arc is struck between a tungsten electrode and the metal workpiece. The weld area is shielded by an inert gas flow to prevent contamination of the tungsten, molten pool and weld area. When the TIG arc is struck, the inert gas is ionised and superheated, changing its molecular structure, which converts it into a plasma stream. This plasma stream flowing between the tungsten and the workpiece is the TIG arc and can be as hot as 19,000°C. It is a very pure and concentrated arc which provides the controlled melting of most metals into a weld pool. TIG welding offers the user the highest amount of flexibility to weld the widest range of material thickness and types. DC TIG welding is also the cleanest weld with no sparks or spatter.

The intensity of the arc is proportional to the current that flows from the tungsten. The welder regulates the welding current to adjust the power of the arc. Typically thin material requires a less powerful arc with less heat to melt the material, so less current (amps) is required. Thicker material requires a more powerful arc with more heat, so more current (amps) are necessary to melt the material.

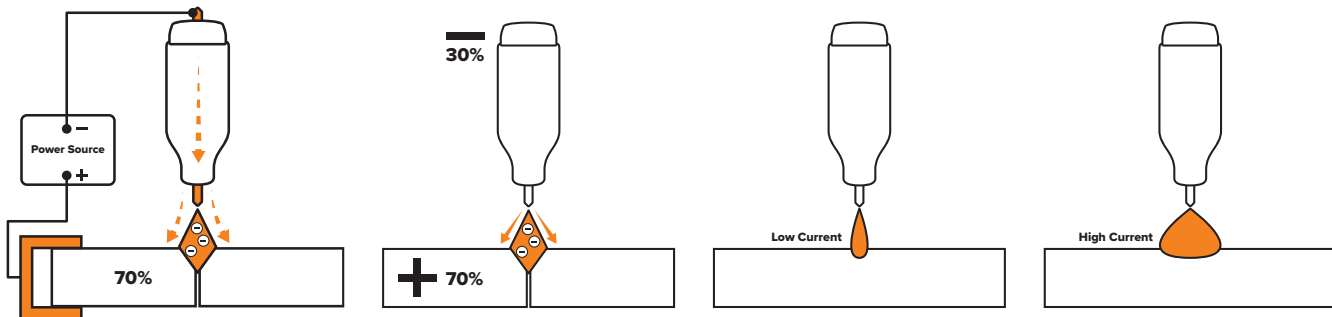

High Frequency Arc Ignition for TIG (Tungsten Inert Gas) Welding

HF (High Frequency) ignition allows the arc to be started in TIG welding without touching the tungsten to the work piece. By pressing the torch switch the machine will activate the gas flow and introduce the HF spark, this "ionises" the air gap making it conductive, allowing an arc to be created without touching the tungsten to the work piece. The gas molecules are superheated by the arc creating a stream of super heated gas that changes the molecular structure into producing a plasma stream. This plasma stream provides heat and energy that allows us to melt and fuse metals in an inert gas shielded environment know as TIG (Tungsten Inert Gas) welding.

DC TIG WELDING GUIDE

Pulse DC TIG Welding

Pulse TIG welding is when the current output (amperage) changes between high and low current. Electronics within the welding machine create the pulse cycle. The high amperage is referred to as peak current, and the low amperage is referred to as base current. During pulse welding the weld pool cools during the low amperage period. This allows a lower overall heat input into the base metal. It allows for controlled heating and cooling periods during welding, providing better control of heat input, weld penetration, operator control and weld appearance.

There are 4 variables within the pulse cycle:

Peak Current - Base Current - Pulse Frequency - Pulse Width

Setting and manipulation of these variables will determine the nature of the weld current output and is at the discretion of the operator.

Peak Current is the main welding current (amps) set to melt the material being welded and works much the same as setting maximum amperage values for regular DC TIG: as a general guide use 30-40 amps for every 1mm of material thickness.

Base Current is the set level of background current (amps) which cools the weld puddle and effects overall heat input. As a rule, use enough background current to reduce the weld pool to about half its normal size while still keeping the weld pool fluid. As a guide start by setting the background amperage at 20 to 30 percent of peak amperage.

Pulse Frequency controls the amount of times per second (Hz) that the welding current switches from Peak Current to Base Current. DC Pulse TIG frequency generally ranges from 20 to 300 HZ depending on the job application. Control of the pulse frequency also determines the appearance of the weld.

Pulse Width is the control of the on time of the peak amp. It is the percentage of time the peak amp is on during one pulsing cycle. Example: with the pulse width set at 80%, the machine will spend 80% of the pulse at peak amperage and 20% at the base amperage. Increasing the pulse width percentage adds more heat to the job, while decreasing pulse width percentage reduces heat.

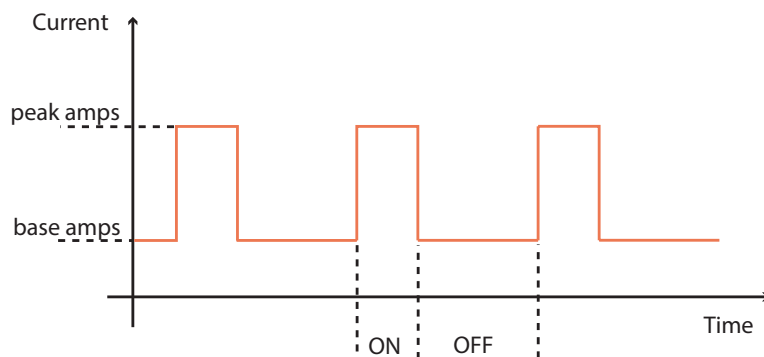

DC Pulse TIG welding allows faster welding speeds with better control of the heat input to the job, reducing the heat input minimising distortion and warping of the work and is of particular advantage in the welding of thin stainless steel and carbon steel applications. The high pulse frequency capability of the advanced inverter agitates the weld puddle and allows you to move quickly without transferring too much heat to the surrounding metal. Pulsing also constricts and focuses the arc, increasing arc stability, penetration and travel speeds.

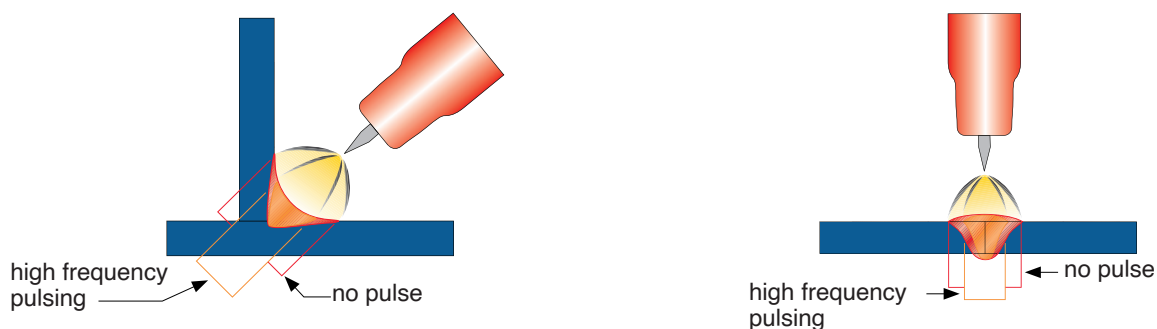

TIG Welding Fusion Technique

Manual TIG welding is often considered the most difficult of all the welding processes. Because the welder must maintain a short arc length, great care and skill are required to prevent contact between the electrode and the workpiece. Similar to Oxygen Acetylene torch welding, TIG welding typically requires two hands and in most instances requires the welder to manually feed a filler wire into the weld pool with one hand while manipulating the welding torch in the other. However, some welds combining thin materials can be accomplished without filler metal, such as edge, corner, and butt joints. This is known as Fusion welding where the edges of the metal pieces are melted together using only the heat and arc force generated by the TIG arc. Once the arc is started, the torch tungsten is held in place until a weld pool is created, a circular movement of the tungsten will assist in creating a weld pool of the desired size. Once the weld pool is established, tilt the torch at about a 75° angle and move smoothly and evenly along the joint while fusing the materials together.

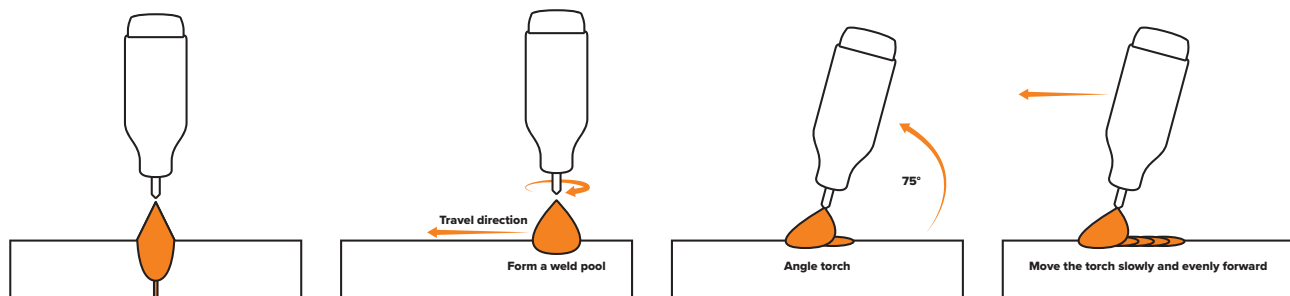

TIG Welding with Filler Wire Technique

It is necessary for many situations with TIG welding to add a filler wire into the weld pool to build up weld reinforcement and create a strong weld. Once the arc is started, the torch tungsten is held in place until a weld pool is created, a circular movement of the tungsten will assist in creating a weld pool of the desired size. Once the weld pool is established, tilt the torch at about a 75° angle and move smoothly and evenly along the joint. The filler metal is introduced to the leading edge of the weld pool. The filler wire is usually held at about a 15° angle and fed into the leading edge of the molten pool. The arc will melt the filler wire into the weld pool as the torch is moved forward. Also, a dabbing technique can be used to control the amount of filler wire added. The wire is fed into the molten pool and retracted in a repeating sequence as the torch is moved slowly and evenly forward. It is essential during the welding to keep the molten end of the filler wire inside the gas shield as this protects the end of the wire from being oxidised and contaminating the weld pool.

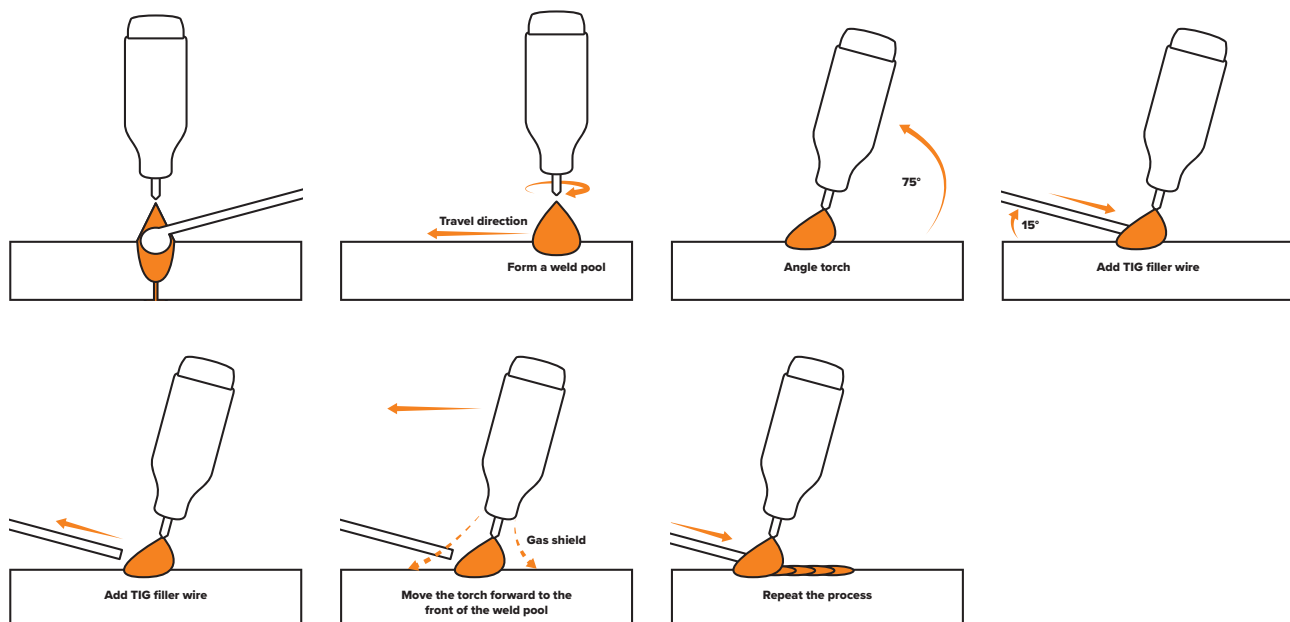

DC TIG WELDING GUIDE

Tungsten Electrodes

- Tungsten is a rare metallic element used for manufacturing TIG welding electrodes. The TIG process relies on tungsten's hardness and high-temperature resistance to carry the welding current to the arc. Tungsten has the highest melting point of any metal, 3,410 degrees Celsius.
- Tungsten electrodes are non-consumable and come in a variety of sizes. They are made from pure tungsten or an alloy of tungsten and other rare earth elements. Choosing the correct tungsten depends on the material being welded, the number of amps required and whether you are using AC or DC welding current.
- Tungsten electrodes are colour-coded at the end for easy identification.
- Below are the most commonly used tungsten electrodes found in the New Zealand and Australian market.

Thoriated (Colour Code: Red)

Thoriated tungsten electrodes (AWS classification EWT_h-2) contain a minimum of 97.30 % tungsten and 1.70 to 2.20 % thorium and are called 2 % thoriated. They are the most commonly used electrodes today and are preferred for their longevity and ease of use. Thorium, however, is a low-level radioactive hazard and many users have switched to other alternatives. Regarding the radioactivity, thorium is an alpha emitter, but when it is enclosed in a tungsten matrix, the risks are negligible. Thoriated tungsten should not get in contact with open cuts or wounds. The more significant danger to welders can occur when thorium oxide gets into the lungs. This can happen from the exposure to vapours during welding or ingestion of material/dust in the grinding of the tungsten. Follow the manufacturer's warnings, instructions, and the Material Safety Data Sheet (MSDS) for its use.

Rare Earth (Colour Code: Purple)

Rare Earth tungsten electrodes (AWS classification EWG) contain a minimum of 98% % tungsten and up to 1.5 % Lanthanum and small percentages of zirconium and yttrium they are called Rare Earth tungsten. Rare Earth tungsten electrodes provide conductivity similar to that of thoriated electrodes. Typically, this means that Rare Earth tungsten electrodes are exchangeable with thoriated electrodes without requiring significant welding process changes. Rare Earth delivers superior arc starting, electrode lifetime, and overall cost-effectiveness. When Rare Earth tungsten electrodes are compared with 2% thoriated tungsten, Rare Earth requires fewer re-grinds and provides a longer overall lifetime. Tests have shown that ignition delay with Rare Earth tungsten electrodes improve over time, while 2% thoriated tungsten starts to deteriorate after only 25 starts. At equivalent energy output, Rare Earth tungsten electrodes run cooler than 2% thoriated tungsten, thereby extending overall tip lifetime. Rare Earth tungsten electrodes work well on AC or DC. They can be used DC electrode positive or negative with a pointed end, or balled for use with AC power sources.

Ceriated (Colour Code: Orange)

Ceriated tungsten electrodes (AWS classification EWC_e-2) contain a minimum of 97.30% tungsten and 1.80 to 2.20% cerium and are referred to as 2% ceriated. Ceriated tungstens perform best in DC welding at low current settings. They have excellent arc starts at low amperages and become popular in such applications as orbital tube welding and thin sheet metal work. They are best used to weld carbon steel, stainless steel, nickel alloys, and titanium. In some cases, it can replace 2% thoriated electrodes. Ceriated tungsten is best suited for lower amperages it should last longer than a Thoriated tungsten. Higher amperage applications are best left to Thoriated or Lanthanated tungstens.

Lanthanated (Colour Code: Gold)

Lanthanated tungsten electrodes (AWS classification EWL_a-1.5) contain a minimum of 97.80 % tungsten and 1.30 % to 1.70 % lanthanum and are known as 1.5 % lanthanated. These electrodes have excellent arc starting, a low burn-off rate, good arc stability, and excellent re-ignition characteristics. Lanthanated tungstens also share the conductivity characteristics of 2 % thoriated tungsten. Lanthanated tungsten electrodes are ideal if you want to optimise your welding capabilities. They work well on AC or DC electrode negative with a pointed end, or they can be balled for use with AC sine wave power sources. Lanthanated tungsten maintains a sharpened point well, which is an advantage for welding steel and stainless steel on DC or AC from square wave power sources.

Zirconiated (Colour Code: White)

Zirconiated tungsten electrodes (AWS classification EWZ_r-1) contain a minimum of 99.10 % tungsten and 0.15 to 0.40 % zirconium. Most commonly used for AC welding, Zirconiated tungsten produces a very stable arc and is resistant to tungsten spitting. It is ideal for AC welding because it retains a balled tip and has a high resistance to contamination. Its current-carrying capacity is equal to or greater than that of thoriated tungsten. Zirconiated tungsten is not recommended for DC welding.

Tungsten Electrodes Rating for Welding Currents

Tungsten Diameter (mm)	Diameter at the Tip (mm)	Constant Included Angle (°)	Current Range (Amps)	Current Range (Pulsed Amps)
1.0mm	0.25	20	5 - 30	5 - 60
1.6mm	0.5	25	8 - 50	5 - 100
1.6mm	0.8	30	10 - 70	10 - 140
2.4mm	0.8	35	12 - 90	12 - 180
2.4mm	1.1	45	15 - 150	15 - 250
3.2mm	1.1	60	20 - 200	20 - 300
3.2mm	1.5	90	25 - 250	25 - 350

Tungsten Preparation

Always use DIAMOND wheels when grinding and cutting. While tungsten is a tough material, the surface of a diamond wheel is harder, and this makes for smooth grinding. Grinding without diamond wheels, such as aluminium oxide wheels, can lead to jagged edges, imperfections, or poor surface finishes not visible to the eye that will contribute to weld inconsistency and weld defects.

Always ensure to grind the tungsten in a longitudinal direction on the grinding wheel. Tungsten electrodes are manufactured with the molecular structure of the grain running lengthwise and thus grinding crosswise is "grinding against the grain." If electrodes are ground crosswise, the electrons have to jump across the grinding marks, and the arc can start before the tip and wander. Grinding longitudinally with the grain causes the electrons to flow steadily and easily to the end of the tungsten tip. The arc starts straight and remains narrow, concentrated, and stable.



Electrode Tip/Flat

The shape of the tungsten electrode tip is an important process variable in precision arc welding. A good selection of tip/flat size will balance the need for several advantages. The bigger the flat, the more likely arc wander will occur and the more difficult it will be to arc start. However, increasing the flat to the maximum level that still allows arc starts and eliminates arc wander will improve the weld penetration and increase the electrode life. Some welders still grind electrodes to a sharp point, which makes arc starting easier. However, they risk decreased welding performance from melting at the tip and the possibility of the point falling off into the weld pool.



Electrode Included Angle/Taper - DC

Tungsten electrodes for DC welding should be ground longitudinally and concentrically with diamond wheels to a specific included angle in conjunction with the tip/flat preparation. Different angles produce different arc shapes and offer different weld penetration capabilities. In general, blunter electrodes that have a larger included angle provide the following benefits:

- Last longer
- Have better weld penetration
- Have a narrower arc shape
- Can handle more amperage without eroding

Sharper electrodes with a smaller included angle provides:

- Offer less arc weld
- Have a wider arc
- Have a more consistent arc

The included angle determines the weld bead shape and size. Generally, as the included angle increases, penetration increases and bead width decreases.



DM26 BINZEL Style Digital MIG Torch

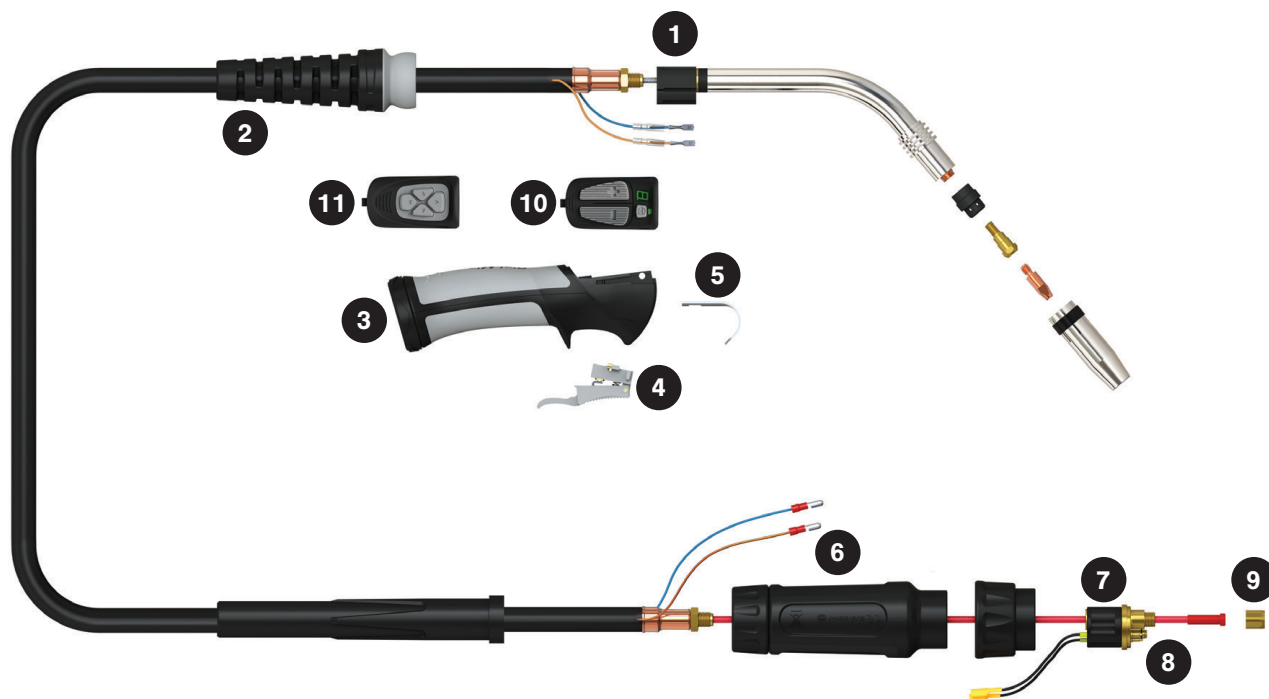

Length	3m	4m	5m
SKU	DM2600-JDM2-MT1-30ER	DM2600-JDM2-MT1-40ER	DM2600-JDM2-MT1-50ER

TORCH SPARES		
1	UG1515	Ergo Handle Location Body
2	UG8015	Handle Cable Support C/W Ball Joint
3	DM2514/KJ	Digi-Mig Handle Kit
4	DM2516L	Extended Trigger Assembly
5	UB2517	Hanger Hook
6	UB1518	Gun Plug Housing C/W Nut
7	UC1528	Hybrid Gun Plug Body C/W Spring Pins
8	UB1524	Gun Plug 'O' Ring
9	UB1525	Liner Nut
10	DM2	Digi-Mig Control Kit
11	MM2	Logic Control Kit for Pulse Machine

TECHNICAL DATA	
COOLING METHOD	Air Cooled
DUTY CYCLE - CO ₂	60% @ 270A
DUTY CYCLE - MIXED GAS	60% @ 240A
WIRE SIZE	0.8-1.2mm
LENGTHS (m)	3/4/5
STANDARD	EN60974-7

DM26 Digital MIG Torch Consumables



SKU	Description	QTY
PCTH26M8S	TIP HOLDER	2



SKU	Description	QTY
PCGD26	Gas Diffuser	2



SKU	Description	QTY
PCT0005-08	CONTACT TIPS - Steel 0.8mm - M8	10
PCT0005-09	CONTACT TIPS - Steel 0.9mm - M8	10
PCT0005-10	CONTACT TIPS - Steel 1.0mm - M8	10
PCT0005-12	CONTACT TIPS - Steel 1.2mm - M8	10
PCTAL0005-08	CONTACT TIPS - Aluminium 0.8mm - M8	10
PCTAL0005-09	CONTACT TIPS - Aluminium 0.9mm - M8	10
PCTAL0005-10	CONTACT TIPS - Aluminium 1.0mm - M8	10
PCTAL0005-12	CONTACT TIPS - Aluminium 1.2mm - M8	10



SKU	Description	QTY
PGN38CON	GAS NOZZLE - Conical	2
PGN38CYL	GAS NOZZLE - Cylindrical	2
PGN38TAP	GAS NOZZLE - Tapered	2



SKU	Description	Wire Size
SLB3M	Blue Steel Liner 3 Metre	0.6 - 0.8mm
SLB4M	Blue Steel Liner 4 Metre	0.6 - 0.8mm
SLB5M	Blue Steel Liner 5 Metre	0.6 - 0.8mm
SLR3M	Red Steel Liner 3 Metre	0.9 - 1.2mm
SLR4M	Red Steel Liner 4 Metre	0.9 - 1.2mm
SLR5M	Red Steel Liner 5 Metre	0.9 - 1.2mm
TLB3M	Blue Aluminium Liner 3 Metre	0.6 - 0.8mm
TLB4M	Blue Aluminium Liner 4 Metre	0.6 - 0.8mm
TLR3M	Red Aluminium Liner 3 Metre	0.9 - 1.2mm
TLR4M	Red Aluminium Liner 4 Metre	0.9 - 1.2mm
TLY3M	Yellow Aluminium Liner 3 Metre	1.2 - 1.6mm
TLY4M	Yellow Aluminium Liner 4 Metre	1.2 - 1.6mm
NKSTL	Neck Spring for Aluminium	

MACHINE PARTS BREAKDOWN

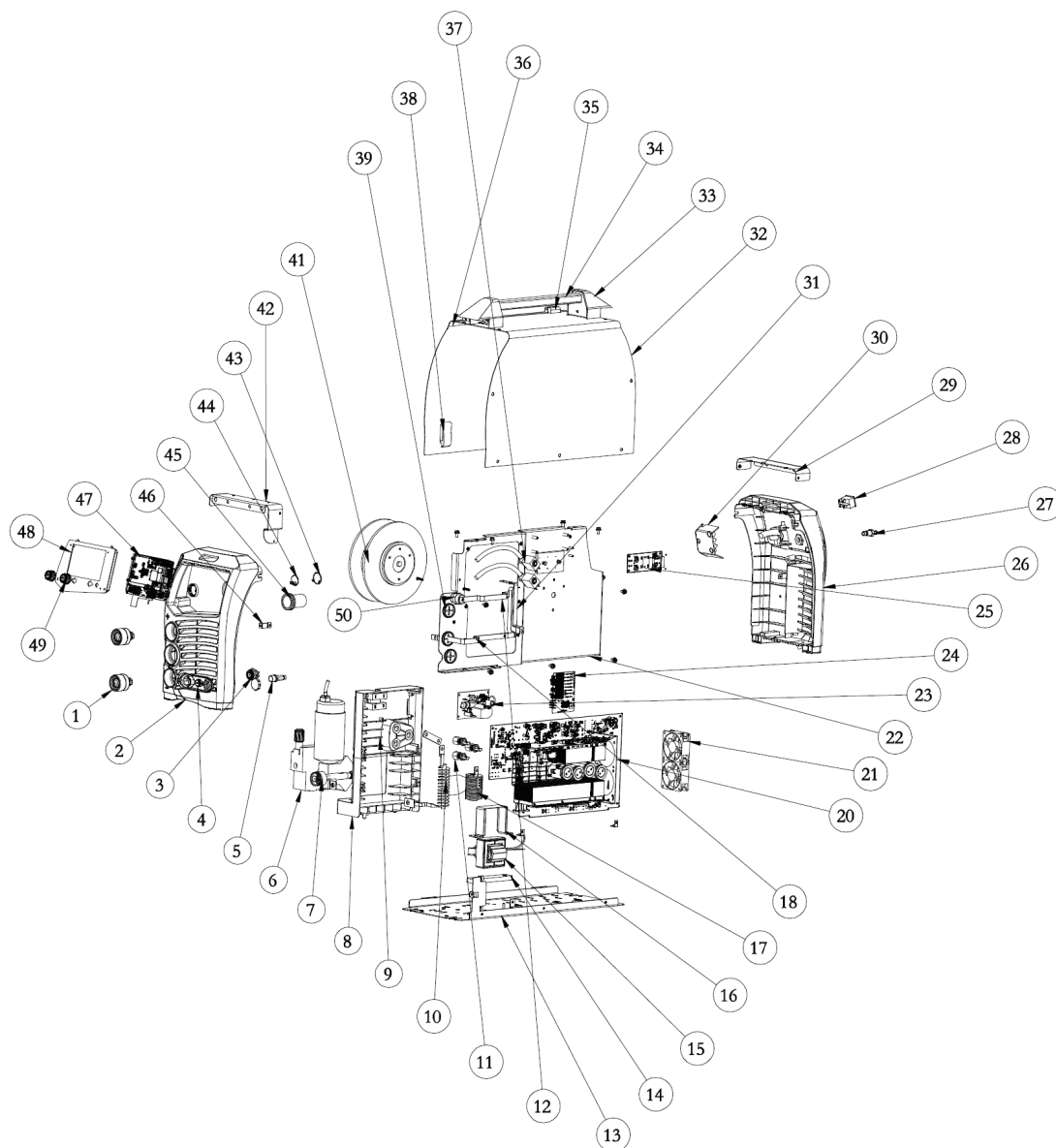

MACHINE SPARES

1	10045432	Quick Socket
2	10078954	Front Panel
3	10083962	12 Core Aviation Socket
4	10083981	12 Core Aviation Socket
5	10041795	Gas Connector
6	10083994	Wire Feeder
7	10083980	Euro Connector
8	10078820	Under The Support Of Wire Feeder
9	10078819	On The Support Of Wire Feeder
10	10083901	Arc Ignition Coil
11	10075799	Copper Terminal
12	10083989	Copper Bar 1
13	10083987	Chassis
14	10078818	Main Transformer Cushion Block
15	10078865	Main Transformer
16	10078814	Main Transformer Support
17	10078869	Reactor
18	10083815	Copper Bar 2
20	10078722	Main Board
21	10078765	Fan
22	10083988	Middle Clapboard
23	10084228	HF Arc Ignition Board
24	10084217	Filtering Board
25	10080580	EMC Board

MACHINE SPARES

26	10078964	Rear Panel
27	10064977	Gas Connector
28	10056467	Rocker Switch
29	10078773	Bracket For Rear Panel
30	10041714	Insulation Cover
31	10083813	Copper Bar 3
32	10083984	Side Cover
33	10058231	Handle Seat
34	10078778	Handle Bar
35	10077387	Damped Sheet
36	10083985	Top Cover
37	10040667	Solenoid Valve
38	10016524	Door Catch
39	10050722	Protective Ring $\phi 30$
41	10054475	Spool Holder
42	10078772	Front Panel Bracket
43	10078822	Lampshade
44	10084343	Light Plate
45	51000360	Protective Coil With Skirt
46	10078883	Angle Support
47	10084371	Display Board
48	51000770	Display Panel
49	30000129	Knob
50	10077038	SM Insulator

WARNING: There are extremely dangerous voltage and power levels present inside this unit. Do not attempt to diagnose or repair unit by removing external cover unless you are an authorised repair agent for UNIMIG.

MIG TROUBLESHOOTING

1. Excessive Spatter

- **Wire feed speed set too high:** Select lower wire feed speed.
- **Voltage too high:** Select a lower voltage setting.
- **Wrong polarity set:** Select the correct polarity for the wire being used - see machine setup guide.
- **Stick out too long:** Bring the torch closer to the work.
- **Contaminated base metal:** Remove materials like paint, grease, oil, and dirt, including mill scale from base metal.
- **Contaminated MIG wire:** Use clean, dry, rust-free wire. Do not lubricate the wire with oil, grease etc.
- **Inadequate gas flow or too much gas flow:** Check the gas is connected, check hoses, gas valve and torch are not restricted. Set the gas flow between 8-12L/min flow rate. Check hoses and fittings for holes, leaks etc.

2. Porosity - Small cavities or holes resulting from gas pockets in weld metal

- **Wrong gas:** Check that the correct gas is being used.
- **Inadequate gas flow or too much gas flow:** Check the gas is connected, check hoses, gas valve and torch are not restricted. Set the gas flow between 8-12L/min flow rate. Check hoses and fittings for holes, leaks etc. Protect the welding zone from wind and drafts.
- **Moisture on the base metal:** Remove all moisture from base metal before welding.
- **Contaminated base metal:** Remove materials like paint, grease, oil, and dirt, including mill scale from base metal.
- **Contaminated MIG wire:** Use clean, dry, rust-free wire. Do not lubricate the wire with oil, grease etc.
- **Gas nozzle clogged with spatter, worn or out of shape:** Clean or replace the gas nozzle.
- **Missing or damaged gas diffuser:** Replace the gas diffuser.
- **MIG torch Euro connect O-ring missing or damaged:** Check and replace the O-ring.

3. Wire stubbing during welding

- **Holding the torch too far away:** Bring the torch closer to the work and maintain stick out of 5-10mm.
- **Welding voltage set too low:** Increase the voltage.
- **Wire feed speed set too high:** Decrease the wire feed speed.

4. Lack of fusion - Failure of weld metal to fuse completely with base metal or a proceeding weld bead

- **Contaminated base metal:** Remove materials like paint, grease, oil, and dirt, including mill scale from base metal.
- **Not enough heat input:** Select a higher voltage range and/or adjust the wire speed to suit.
- **Improper welding technique:** Keep the arc at the leading edge of the weld pool. Gun angle to work should be between 5° & 15°. Direct the arc at the weld joint. Adjust work angle or widen groove to access bottom during welding. Momentarily hold arc on side walls if using weaving technique.

5. Excessive penetration - Weld metal melting through base metal

- **Too much heat:** Select a lower voltage range and/or adjust the wire speed to suit. Increase travel speed.

6. Lack of penetration - Shallow fusion between weld metal and base metal

- **Poor or incorrect joint preparation:** Material too thick. Joint preparation and design needs to allow access to bottom of groove while maintaining proper welding wire extension and arc characteristics. Keep the arc at the leading edge of the weld pool and maintain the gun angle at 5° & 15° keeping the stick out between 5-10mm.
- **Not enough heat input:** Select a higher voltage range and/or adjust the wire speed to suit. Reduce travel speed.
- **Contaminated base metal:** Remove materials like paint, grease, oil, and dirt, including mill scale, from base metal.

7. No wire feed

- **Wrong mode selected:** Check that the TIG/MMA/MIG selector switch is set to MIG position.
- **Wrong torch selector switch:** Check that the STANDARD/SPOOL GUN selector switch is set to STANDARD position for MIG welding and SPOOL GUN when using the spool gun.

8. Inconsistent/interrupted wire feed

- **Adjusting wrong dial:** Be sure to adjust the WIRE FEED and VOLTAGE dials for MIG welding. The AMPERAGE dial is for STICK and TIG welding mode.
- **Wrong polarity selected:** Select the correct polarity for the wire being used - see machine setup guide.
- **Incorrect wire speed setting:** Adjust the wire feed speed.
- **Voltage setting incorrect:** Adjust the voltage setting.
- **MIG torch lead too long:** Small diameter wires and soft wires like aluminium don't feed well through long torch leads - replace the torch with a lesser length torch.
- **MIG torch lead kinked or too sharp angle being held:** Remove the kink, reduce the angle or bend.
- **Contact tip worn, wrong size, wrong type:** Replace the tip with correct size and type.
- **Liner worn or clogged (the most common causes of bad feeding):** Try to clear the liner by blowing out with compressed air as a temporary cure. It is recommended to replace the liner.
- **Wrong size liner:** Install the correct size liner.
- **Blocked or worn inlet guide tube:** Clear or replace the inlet guide tube.
- **Wire misaligned in drive roller groove:** Locate the wire into the groove of the drive roller.
- **Incorrect drive roller size:** Fit the correct size drive roller e.g. 0.8mm wire requires 0.8mm drive roller.
- **Wrong type of drive roller selected:** Fit the correct type roller (e.g. knurled rollers needed for flux cored wires).
- **Worn drive rollers:** Replace the drive rollers.
- **Drive roller pressure too high:** Can flatten the wire electrode causing it to lodge in the contact tip - reduce the drive roller pressure.
- **Too much tension on wire spool hub:** Reduce the spool hub brake tension.
- **Wire crossed over on the spool or tangled:** Remove the spool, untangle the wire or replace the wire.
- **Contaminated MIG wire:** Use clean, dry, rust-free wire. Do not lubricate the wire with oil, grease etc.

TIG TROUBLESHOOTING

1. Tungsten burning away quickly

- **Incorrect gas or no gas:** Use pure argon. Check cylinder has gas is connected, turned on and torch valve is open.
- **Inadequate gas flow:** Check the gas is connected, check hoses, gas valve and torch are not restricted.
- **Back cap not fitted correctly:** Make sure the torch back cap is fitted so that the O-ring is inside the torch body.
- **Torch connected to DC+:** Connect the torch to the DC- output terminal.
- **Incorrect tungsten being used:** Check and change the tungsten type if necessary.
- **Tungsten being oxidised after weld is finished:** Keep shielding gas flowing 10-15 seconds after arc stoppage. 1 second for each 10 amps of weld current.

2. Contaminated tungsten

- **Touching tungsten into the weld pool:** Keep tungsten from contacting weld puddle. Raise the torch so that the tungsten is off of the work piece 2-5mm.
- **Touching the filler wire to the tungsten:** Keep the filler wire from touching the tungsten during welding, feed the filler wire into the leading edge of the weld pool in front of the tungsten.

3. Porosity - Poor weld appearance and colour

- **Wrong gas / poor gas flow / gas leaks:** Use pure argon. Gas is connected, check hoses, gas valve and torch are not restricted. Set the gas flow between 6-10L/min. Check hoses and fittings for holes, leaks etc.
- **Contaminated base metal:** Remove moisture and materials like paint, grease, oil, and dirt from base metal.
- **Contaminated filler wire:** Remove all grease, oil, or moisture from filler metal.
- **Incorrect filler wire:** Check the filler wire and change if necessary.

4. Yellowish residue/smoke on the alumina nozzle & discoloured tungsten

- **Incorrect gas:** Use pure argon gas.
- **Inadequate gas flow:** Set the gas flow between 6-10L/min flow rate.
- **Alumina gas nozzle too small:** Increase the size of the alumina gas nozzle.

5. Unstable arc during DC welding

- **Torch connected to DC+:** Connect the torch to the DC- output terminal.
- **Contaminated base metal:** Remove materials like paint, grease, oil, and dirt, including mill scale from base metal.
- **Tungsten is contaminated:** Remove 10mm of contaminated tungsten and re-grind the tungsten.
- **Arc length too long:** Lower torch so that the tungsten is off of the work piece 2-5mm.

6. Arc wanders during DC welding

- **Poor gas flow:** Check and set the gas flow between 6-10L/min flow rate.
- **Incorrect arc length:** Lower torch so that the tungsten is off of the work piece 2-5mm.
- **Tungsten incorrect or in poor condition:** Check that correct type of tungsten is being used. Remove 10mm from the weld end of the tungsten and re-sharpen the tungsten.
- **Poorly prepared tungsten:** Grind marks should run lengthwise with tungsten, not circular. Use proper grinding method and wheel.
- **Contaminated base metal or filler wire:** Remove contaminating materials like paint, grease, oil, and dirt, including mill scale, from base metal. Remove all grease, oil, or moisture from filler metal.

7. Arc difficult to start or will not start DC welding

- **Incorrect machine set up:** Check machine set up is correct.
- **No gas, incorrect gas flow:** Check the gas is connected and cylinder valve open, check hoses, gas valve and torch are not restricted. Set the gas flow between 6-10L/min flow rate.
- **Incorrect tungsten size or type:** Check and change the size and or the tungsten if required.
- **Loose connection:** Check all connectors and tighten.
- **Earth clamp not connected to work:** Connect the earth clamp directly to the workpiece wherever possible.

MMA (STICK) TROUBLESHOOTING

1. No arc

- **Incomplete welding circuit:** Check earth lead is connected. Check all cable connections.
- **Wrong mode selected:** Check the MMA selector switch is selected.
- **No power supply:** Check that the machine is switched on and has a power supply.

2. Porosity - Small cavities or holes resulting from gas pockets in weld metal

- **Arc length too long:** Shorten the arc length.
- **Work piece dirty, contaminated or moisture:** Remove moisture and materials like paint, grease, oil, and dirt, including mill scale, from base metal.
- **Damp electrodes:** Use only dry electrodes.

3. Excessive Spatter

- **Amperage too high:** Decrease the amperage or choose a larger electrode.
- **Arc length too long:** Shorten the arc length.

4. Weld sits on top, lack of fusion

- **Insufficient heat input:** Increase the amperage or choose a larger electrode.
- **Work piece dirty, contaminated or moisture:** Remove moisture and materials like paint, grease, oil, and dirt, including mill scale, from base metal.
- **Poor welding technique:** Use the correct welding technique or seek assistance for the correct technique.

5. Lack of penetration

- **Insufficient heat input:** Increase the amperage or choose a larger electrode.
- **Poor welding technique:** Use the correct welding technique or seek assistance for the correct technique.
- **Poor joint preparation:** Check the joint design and fit up, make sure the material is not too thick. Seek assistance for the correct joint design and fit up.

6. Excessive penetration - Burn through

- **Excessive heat input:** Reduce the amperage or use a smaller electrode.
- **Incorrect travel speed:** Try increasing the weld travel speed.

7. Uneven weld appearance

- **Unsteady hand, wavering hand:** Use two hands where possible to steady up, practise your technique.

8. Distortion - Movement of base metal during welding

- **Excessive heat input:** Reduce the amperage or use a smaller electrode.
- **Poor welding technique:** Use the correct welding technique or seek assistance for the correct technique.
- **Poor joint preparation and or joint design:** Check the joint design and fit up, make sure the material is not too thick. Seek assistance for the correct joint design and fit up.

9. Electrode welds with different or unusual arc characteristic

- **Incorrect polarity:** Change the polarity, check the electrode manufacturer for correct polarity.

ERROR CODE LIST

Error Code	Error	Error Description	Recommended action	Possible Cause
1	Exceeding internal voltage limits	Critical supply voltage in the main control board.	<ul style="list-style-type: none"> Restart the machine. If the problem still exists then contact the service centre. 	<ul style="list-style-type: none"> The main control board fault
2	Backup voltage failure	Backup voltage failure.	<ul style="list-style-type: none"> Restart the machine. If the problem still exists then contact the service centre. 	<ul style="list-style-type: none"> Low battery
3	High CPU temperature	The CPU temperature is too high.	<ul style="list-style-type: none"> Power off the machine and wait a few minutes to cool down the CPU. If the problem still exists then contact the service centre. 	<ul style="list-style-type: none"> High ambient temperature
10	Error in the unique identifier	Error in the unique identifier	<ul style="list-style-type: none"> Restart the machine. If the problem still exists then contact the service centre. 	<ul style="list-style-type: none"> Fault in the main control board. Bad electrical connection
11	Alarm 24V	The power supply outside the limits of 24V DC.	<ul style="list-style-type: none"> Restart the machine. If the problem still exists then contact the service centre. 	<ul style="list-style-type: none"> Control board fault Supply board fault
12	Alarm 5V	The power supply outside the limits of 5V DC.	<ul style="list-style-type: none"> Restart the machine. If the problem still exists then contact the service centre. 	<ul style="list-style-type: none"> Control board fault Supply board fault
13	Alarm -15V	The power supply outside the limits of -15V DC.	<ul style="list-style-type: none"> Restart the machine. If the problem still exists then contact the service centre. 	<ul style="list-style-type: none"> Control board fault Supply board fault
14	Alarm +15V	The power supply outside the limits of +15V DC.	<ul style="list-style-type: none"> Restart the machine. If the problem still exists then contact the service centre. 	<ul style="list-style-type: none"> Control board fault Supply board fault
15	Hall sensor	Anomaly in the read out in the output current	<ul style="list-style-type: none"> Restart the machine. If the problem still exists then contact the service centre. 	<ul style="list-style-type: none"> Bad electrical connection Fault in the main control board
17	Internal memory failure	Memory anomaly.	<ul style="list-style-type: none"> Restart the machine. If the problem still exists then contact the service centre. 	<ul style="list-style-type: none"> Problem with the machine firmware
18	Error in DC bus voltage	Main inverter supply voltage anomaly.	<ul style="list-style-type: none"> Restart the machine. If the problem still exists then contact the service centre. 	<ul style="list-style-type: none"> Main power supply board fault.
20	High probe voltage	Output voltage anomaly.	<ul style="list-style-type: none"> Restart the machine. If the problem still exists then contact the service centre. 	<ul style="list-style-type: none"> Main power supply fault Fault in the main control board
21	Unknown function	Selected program is not available.	<ul style="list-style-type: none"> Contact your dealer or visit the cloud to add additional welding programs 	
22	Front panel display error	Front panel error.	<ul style="list-style-type: none"> Restart the machine. If the problem still exists then contact the service centre. 	<ul style="list-style-type: none"> Control board fault front panel fault
23	Analogue to digital converter error	Internal error in the control board	<ul style="list-style-type: none"> Restart the machine. If the problem still exists then contact the service centre. 	<ul style="list-style-type: none"> Control board fault
30	Torch in short circuit	Torch in short circuit.	<ul style="list-style-type: none"> Check the output connections make sure the torch doesn't touch the work desk or the negative cabling 	<ul style="list-style-type: none"> Torch connected on the working desk. There is problem with grounding connection or wire.
40	Inverter temperature error	Temperature sensor ntc1. Inverter rose heat max temperature.	<ul style="list-style-type: none"> Turn off the machine and wait a few moments until the inverter arrived at the stable temperature. If the problem still exists then contact the service centre 	<ul style="list-style-type: none"> Fault in the inverter temperature sensor. The inverter temperature sensor is disconnected.

FAQ & TROUBLESHOOTING

Error Code	Error	Error Description	Recommended action	Possible Cause
41	P&p connector temperature	Error in the Plug & Play temperature sensor ntc2.	<ul style="list-style-type: none"> Restart the machine. If the problem still exists then contact the service centre. 	<ul style="list-style-type: none"> Fault in the Plug & Play temperature sensor. The Plug & Play temperature sensor is disconnected. Fault in the cooling system.
42	Temperature sensor-1	Temperature sensor 1 error.	<ul style="list-style-type: none"> Wait a few moments until the alarm disappears. Check the cooling fan. If the problem still exists then contact the service centre. 	<ul style="list-style-type: none"> Overheating fault cooling system.
43	Temperature sensor-2	Temperature sensor 2 error.	<ul style="list-style-type: none"> Wait a few moments until the alarm disappears. Check the cooling fan. If the problem still exists then contact the service centre. 	<ul style="list-style-type: none"> Control board fault.
44	High inverter temperature	Inverter overheating.	<ul style="list-style-type: none"> Wait a few moments until the alarm disappears. Check the cooling fan. If the problem still exists then contact the service centre. 	<ul style="list-style-type: none"> Fault cooling system.
45	High Plug & Play temperature	Plug & Play connector overheating please wait the cooling down time.	<ul style="list-style-type: none"> Wait a few minutes until the alarm disappears. Check the cooling fan. If the problem still exists then contact the service centre. 	<ul style="list-style-type: none"> Overworking.
50	Power frequency error	The frequency of the input voltage is out of tolerance(50/60hz).	<ul style="list-style-type: none"> Restart the machine. If the problem still exists then contact the service centre. 	<ul style="list-style-type: none"> Wrong power supply network.
51	Low voltage	The power supply voltage is below the minimum input voltage.	<ul style="list-style-type: none"> Restart the machine. If the problem still exists then contact the service centre. 	<ul style="list-style-type: none"> Check the power supply input resource. Fault in the main control board.
52	High voltage	The power supply voltage is above the maximum input voltage.	<ul style="list-style-type: none"> Restart the machine. If the problem still exists then contact the service centre. 	<ul style="list-style-type: none"> Check the power supply input resource. Fault in the main control board.
53	Undefined voltage	The power supply voltage is undefined.	<ul style="list-style-type: none"> Restart the machine. If the problem still exists then contact the service centre. 	
54	Missing phase	Missing a phase in the power supply voltage.	<ul style="list-style-type: none"> Restart the machine. If the problem still exists then contact the service centre. 	
55	Unknown voltage error	Wrong power supply connection.	<ul style="list-style-type: none"> Restart the machine. If the problem still exists then contact the service centre. 	
60	Pre-load error	Start-up control failure.	<ul style="list-style-type: none"> Restart the machine. If the problem still exists then contact the service centre. 	
61	PWM inverter error	Start-up inverter control failure.	<ul style="list-style-type: none"> Restart the machine. If the problem still exists then contact the service centre. 	<ul style="list-style-type: none"> Fault in the power inverter.
62	Wire feeder motor error	Error in the wire feeder motor power supply.	<ul style="list-style-type: none"> Restart the machine. If the problem still exists then contact the service centre. 	<ul style="list-style-type: none"> Wire feeder is not connected to power source or connection is faulty.
63	PWM wire feeder motor error	Power supply anomaly of the wire feeder motor.	<ul style="list-style-type: none"> Restart the machine. If the problem still exists then contact the service centre. 	<ul style="list-style-type: none"> Error in the communication with the main machine.
64	Wire feeder motor voltage error	Over-current in the wire feeder motor.	<ul style="list-style-type: none"> Restart the machine. If the problem still exists then contact the service centre. 	<ul style="list-style-type: none"> Error in the communication with the main machine.
65	Plug & Play communication error 485	Communication error with connected Plug & Play module.	<ul style="list-style-type: none"> Restart the machine. If the problem still exists then contact the service centre. 	<ul style="list-style-type: none"> Connection problem with the machine. Broken/damage Plug & Play module connector. Fault in the Plug & Play module control board.

FAQ & TROUBLESHOOTING

Error Code	Error	Error Description	Recommended action	Possible Cause
66	Hardware error	Hardware error in the power inverter.	<ul style="list-style-type: none"> Restart the machine. If the problem still exists then contact the service centre. 	
67	Invalid calibration	Out of range of the calibration data	<ul style="list-style-type: none"> Restart the machine. If the problem still exists then contact the service centre. 	<ul style="list-style-type: none"> Error during the calibration process.
68	Alarm pWM PFC	Error in the power factor control driver.	<ul style="list-style-type: none"> Restart the machine. If the problem still exists then contact the service centre. 	
70	Internal thermal cycle error	Error in the internal thermal cycle. Max power limit exceeded	<ul style="list-style-type: none"> Restart the machine. If the problem still exists then contact the service centre. 	
71	External thermal cycle error	Welding time limit exceeded. Thermal cycle limit exceeded.	<ul style="list-style-type: none"> Wait a few moments for thermal overload to cool down. 	<ul style="list-style-type: none"> All welding machines are (or should be) fitted with thermal overload protection which means the machine will cut out when external critical components reach a certain temperature, to prevent damage. The machine will then restart when it returns to a safe temperature
72	Wire feeder motor speed error	The wire feeder motor speed is out of the limits.	<ul style="list-style-type: none"> Check torch consumable parts, pressure of the rolls. 	<ul style="list-style-type: none"> Torch quality. Bad motor fixing rolls.
73	Wire feeder motor encoder error	Missing feedback from the motor speed sensor.	<ul style="list-style-type: none"> Restart the machine. If the problem still exists then contact the service centre. 	<ul style="list-style-type: none"> Fault of the control board. Fault of the speed sensor
74	Wire feeder motor wrong direction alarm	The wire feeder motor is rotating in the wrong direction.	<ul style="list-style-type: none"> Restart the machine. If the problem still exists then contact the service centre. 	
75	Short circuit in MIG	Short circuit in MIG mode.	<ul style="list-style-type: none"> Check the output connections make sure the torch doesn't touch the work desk or the negative cabling. 	
76	Wire feeder motor braking error	Wire feeder motor's brake isn't working properly.	<ul style="list-style-type: none"> Restart the machine. If the problem still exists then contact the service centre. 	<ul style="list-style-type: none"> Fault control board
80	Diter isn't working	Communication error with cloud control circuit.	<ul style="list-style-type: none"> (Evolve 200) press the right upper button to reset the alarm power off and power on the machine (evolve 200 plus) (evolve 500) 	<ul style="list-style-type: none"> Fault control board. Fault cloud connection board.
90	Low gas pressure	Low gas pressure.	<ul style="list-style-type: none"> Check the gas supply. 	
91	High gas pressure	High gas pressure.	<ul style="list-style-type: none"> Check the gas supply. 	
92	Low gas flow	Low gas flow.	<ul style="list-style-type: none"> Check the gas supply. 	
93	High gas flow	High gas flow.	<ul style="list-style-type: none"> Check the gas supply. 	
100	Exceeding internal voltage limits	Critical supply voltage in the main control circuit.	<ul style="list-style-type: none"> Restart the machine. If the problem still exists then contact the service centre. 	
101	CMOS battery failure	Backup voltage failure.	<ul style="list-style-type: none"> Restart the machine. If the problem still exists then contact the service centre. 	
102	High CPU temperature	The CPU temperature is too high (80°C).	<ul style="list-style-type: none"> Restart the machine then wait a few moments until it's cooled down 	
103	Error in the UID chipset	Communication error in the internal circuits.	<ul style="list-style-type: none"> Restart the machine. If the problem still exists then contact the service centre. 	

FAQ & TROUBLESHOOTING

Error Code	Error	Error Description	Recommended action	Possible Cause
104	Alarm 24v	The power supply outside the limits of 24V DC.	<ul style="list-style-type: none"> Restart the machine. If the problem still exists then contact the service centre. 	<ul style="list-style-type: none"> Overload in the power supply or communication error with the power inverter.
105	Alarm 5v	The power supply outside the limits of 5V DC.	<ul style="list-style-type: none"> Restart the machine. If the problem still exists then contact the service centre. 	<ul style="list-style-type: none"> Overload in the power supply or communication error with the power inverter.
106	Alarm -15v	The power supply outside the limits of -15V DC.	<ul style="list-style-type: none"> Restart the machine. If the problem still exists then contact the service centre. 	<ul style="list-style-type: none"> Overload in the power supply or communication error with the power inverter.
107	Alarm +15v	The power supply outside the limits of +15V DC.	<ul style="list-style-type: none"> Restart the machine. If the problem still exists then contact the service centre. 	<ul style="list-style-type: none"> Overload in the power supply or communication error with the power inverter.
110	Inverter temperature error	Error in the inverter temperature sensor.	<ul style="list-style-type: none"> Restart the machine. If the problem still exists then contact the service centre. 	
111	P&p temperature error	Error in the Plug & Play temperature sensor.	<ul style="list-style-type: none"> Restart the machine. If the problem still exists then contact the service centre. 	
112	Short circuit in the NTC 1 sensor	Short circuit in the inverter temperature sensor.	<ul style="list-style-type: none"> Restart the machine. If the problem still exists then contact the service centre. 	
113	Short circuit in the NTC 2 sensor	Short circuit in the Plug & Play temperature sensor.	<ul style="list-style-type: none"> Restart the machine. If the problem still exists then contact the service centre. 	
150	Missing water circulation	Insufficient water in the cooler unit.	<ul style="list-style-type: none"> Insufficient water in the tank Fault in the water pump. Refill the water tank. 	
151	Low water circulation	Low water flow in the cooler unit.	<ul style="list-style-type: none"> Insufficient water in the tank Fault in the water pump. Refill the water tank. 	
152	High water circulation	High water flow in the cooler unit.	<ul style="list-style-type: none"> Fault in the water pump. 	
153	High water temperature	High water temperature.	<ul style="list-style-type: none"> Fault in the water pump. 	
154	High water pump temperature	Water pump temperature is high	<ul style="list-style-type: none"> Restart the machine. If the problem still exists then contact the service centre. 	
171	Wire feeder motor encoder error	Missing feedback from the motor speed sensor.	<ul style="list-style-type: none"> Restart the machine. If the problem still exists then contact the service centre. 	
172	Wire feeder motor speed error	The wire feeder motor speed is out of the limits.	<ul style="list-style-type: none"> Blockage in the torch. Check the wire exit point. 	
173	Wire feeder motor wrong direction alarm	The wire feeder motor is rotating in the wrong direction.	<ul style="list-style-type: none"> Check the power cable. Check the encoder connection. 	
302	Start-up firmware download fail	Start-up firmware download fail.	<ul style="list-style-type: none"> Check if the machine is connected to the internet. 	
303	Wrong start-up firmware check	Start-up firmware verification failed.	<ul style="list-style-type: none"> Check if the machine is connected to the internet. 	
304	Recovery firmware download fail	Recovery firmware download fail.	<ul style="list-style-type: none"> Check if the machine is connected to the internet. 	
305	Wrong recovery firmware check	Recovery firmware verification failed.	<ul style="list-style-type: none"> Check if the machine is connected to the internet. 	
306	Machine firmware download fail	Machine firmware download fail.	<ul style="list-style-type: none"> Check if the machine is connected to the internet. 	
307	Wrong machine firmware check	Machine firmware verification failed.	<ul style="list-style-type: none"> Check if the machine is connected to the internet. 	

FAQ & TROUBLESHOOTING

Error Code	Error	Error Description	Recommended action	Possible Cause
308	Recovery performed		<ul style="list-style-type: none">Restart the machine.If the problem still exists then contact the service centre.	
333	WiFi crashed	WiFi crashed.	<ul style="list-style-type: none">Restart the machine.If the problem still exists then contact the service centre.	
334	Flash read only		<ul style="list-style-type: none">Restart the machine.If the problem still exists then contact the service centre.	
335	Internal communication error	Internal communication error.	<ul style="list-style-type: none">Restart the machine.If the problem still exists then contact the service centre.	

UNIMIG®

BUILT FOR WELDERS

HEAD OFFICE:

112 Christina Rd,
Villawood NSW 2163

PH: (02) 9780 4200
FAX: (02) 9780 4210

EMAIL: sales@unimig.com.au

QLD OFFICE:

19 Commerce Cct,
Yatala QLD 4207

PH: (07) 3333 2855
FAX: (07) 3274 5829

EMAIL: qld@unimig.com.au

VIC OFFICE:

91 Yellowbox Drive,
Craigieburn VIC 3064

PH: (03) 8682 9911
FAX: (03) 9333 7867

EMAIL: vicsales@unimig.com.au

WA OFFICE:

26 Sustainable Ave,
Bibra Lake WA 6163

PH: (08) 6363 5111
FAX: (08) 9417 4781

EMAIL: wasales@unimig.com.au